

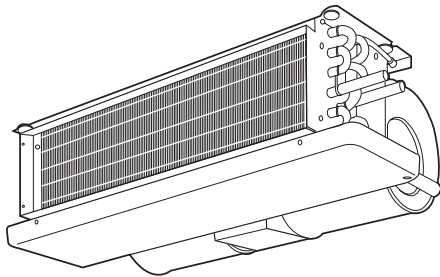

Product Data

42C,D,S,V Series Fan Coil Air Conditioners 50/60 Hz

150 to 2000 cfm



42CA HORIZONTAL

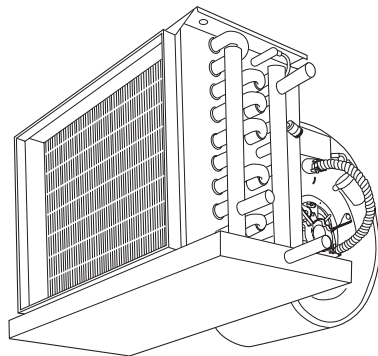

42DA DUCTED

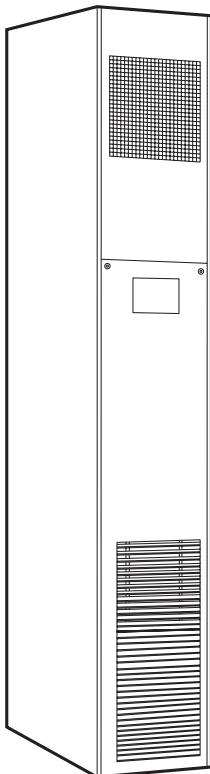

42SH STACK

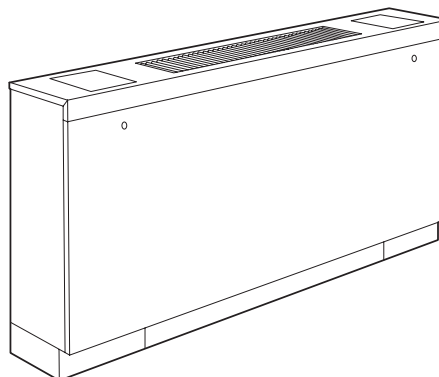

42VB VERTICAL

Carrier's 42C,D,S,V Series fan-coil units combine design flexibility with easy, low-cost installation.

Features/Benefits

Versatility

If room fan coils are the answer to your job requirements, choose from Carrier's extensive range of superior fan-coil units.

With Carrier's 42 series fan coils, you can select from 5 horizontal, 6 vertical, 5 ducted or 3 stacked models; furred-in or cabinet style, slant top or low silhouette, in 150 through 2000 cfm capacities. Coils are available with 1, 2, 3, 4, or 5 rows (depending on model), to satisfy a variety of application requirements. The units are ideal for installation in motels, apartments, and other multi-room buildings. Many optional control packages are available, including 2-pipe heating and cooling, 2-pipe heating and cooling with auxiliary electric heat, 2-pipe cooling with total electric heat, and 4-pipe heating and cooling. Also offered are manual and automatic changeover controls and several thermostat options.

Casings and frame are fabricated from tough, heavy gage galvanized steel. Optional decorative colors allow the unit to blend with any interior design.

Low-cost installation and operation

Each unit is designed to occupy a minimum space. No complex system controls are required for Carrier fan coil units. Piping, drain, and wiring connections are readily accessible and mounting holes and slots are pre-drilled to save installation time and field labor expense.



42 Series quality reduces service and maintenance expenses

Condensate drain pan is heavy gage galvanized steel with closed-cell, fire retardant foam insulation. Units come standard with Tuf-Skin™ II insulation for energy savings, sound absorption and Indoor Air Quality (IAQ) preservation. Water never touches the pan, so corrosion is minimized and long, trouble-free life is assured.

Efficient operation

All units use permanent split capacitor motors for minimum electrical consumption. Blower wheels are centrifugal-type, forward curved, double width, and double inlet sized for maximum efficiency.

Quiet, dependable performance

All units are built to operate unobtrusively with quiet motors and fans. In addition, 1/2-in. thick sound-absorbing, multi-density, matt faced, neoprene-coated fiberglass insulation is used to line the cabinet.

42C series horizontal, 42V series vertical units

Carrier room fan-coil units operate at exceptionally low sound levels. A generous amount of insulation absorbs operating sound and rugged, rigid construction ensures vibration free operation at all fan speeds.

Economical, three-speed fans deliver just the right amount of conditioned air for your comfort needs at any load, and each unit can be shut off when not in use. Permanent split capacitor motors deliver peak operating efficiency. By choosing Carrier units, you can match your application with a wide range of custom-designed options and accessories, including electric heat. Filters are cleanable or throwaway type.

Motor bearings are heavy-duty sleeve type, with oversize oil reservoirs to assure long bearing life. All coils are factory leak-tested at 350 psig minimum air pressure.

Carrier room fan-coil units provide unsurpassed year-round comfort, with heating and cooling performance certified in compliance with ARI (Air Conditioning & Refrigeration Institute) 440-98.

42D ducted units

A drip lip (removable drain pan extension) is provided for field installation on ceiling models 42DA,DC,DE and DF when a motorized valve package is ordered. The drip lip is also available as an accessory for use with other controls.

Motor/blower assembly can be easily removed from the unit for ease of service. Removing this assembly provides clear access to the entering air face of the coil, making coil cleaning a relatively simple matter. Removable panels make access to components and connections easy.

42S stacked units

Each Carrier stack unit comes factory-equipped with insulated supply, return, and drain risers. The design of the 42S units allow them to be set one on top of the other in a vertical column rising floor to floor up the building. Each riser has a 3-in. belled section at the top, so the riser piping can be

connected by only one sweat connection per riser. Field-installed couplings or internal pipe connections are not needed.

Each stack unit is factory pre-wired with all control, motor, and optional electric heat wiring conveniently terminating in a single, accessible junction box. Each stack unit requires only one field power connection.

Field-mounted accessories, such as the 3-speed switch/thermostat package for furred-in units, are equipped with a pre-wired quick disconnect plug for easy installation.

The riser size for the stack units can be specified to match building requirements so that cutting, sorting, and handling of the risers is not necessary. All units arrive tagged as specified by the customer for efficient delivery to the correct building location.

Units can be loaded onto delivery trucks so that they can be off-loaded in the proper installation sequence.

Table of contents

	Page
Features/Benefits	1-6
Options and Accessories	7-9
Controls	10-12
Application Data	13-25
Selection Procedure	26
42C,V	
Model Number Nomenclature	27
ARI Capacity Ratings	28
Sound data	29,30
Physical Data and Dimensions	31-42
Accessory Dimensions	43-47
Performance Data	48-63
Electrical Data	64-66
42D	
Model Number Nomenclature	67
ARI Capacity Ratings	67
Sound data	68
Physical Data and Dimensions	68-73
Accessory Dimensions	74-76
Performance Data	77-86
Electrical Data	87-89
42S	
Model Number Nomenclature	90
ARI Capacity Ratings	90
Sound data	91
Physical Data and Dimensions	91-94
Accessory Dimensions	95-97
Performance Data	98-103
Electrical Data	104
Guide Specifications — 42C Series	105,106
Guide Specifications — 42D Series	107,108
Guide Specifications — 42S Series	109-111
Guide Specifications — 42V Series	112,113

Features/Benefits (cont)

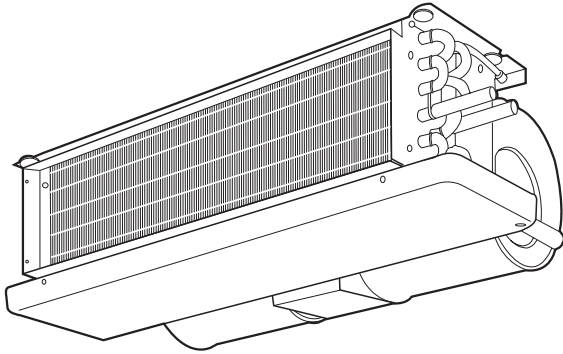

42CA
Furred-in ceiling model with low silhouette.
(200-1200 cfm)

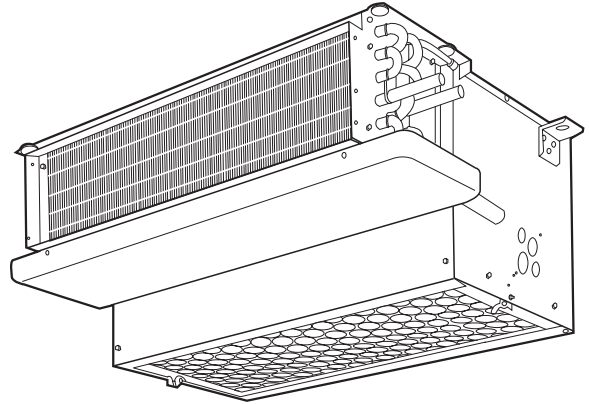

42CF
High-static, furred-in model.
(400-1000 cfm)

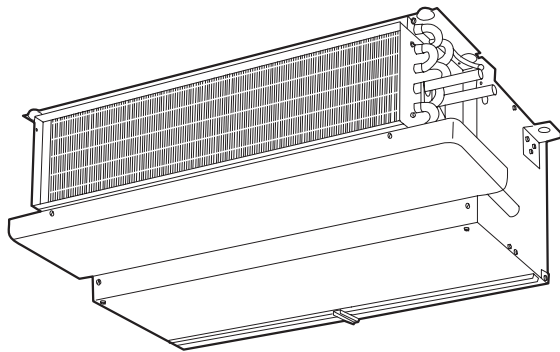

42CE
Furred-in ceiling model with factory-installed plenum.
(200-1200 cfm)

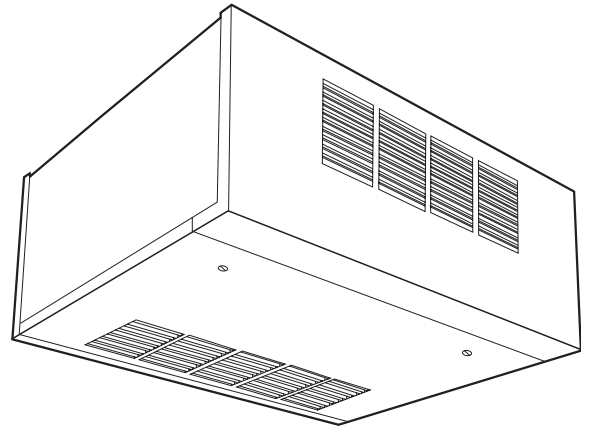

42CG
Cabinet model for under-ceiling mount with bottom or rear stamped louver return air grille.
(200-1200 cfm)

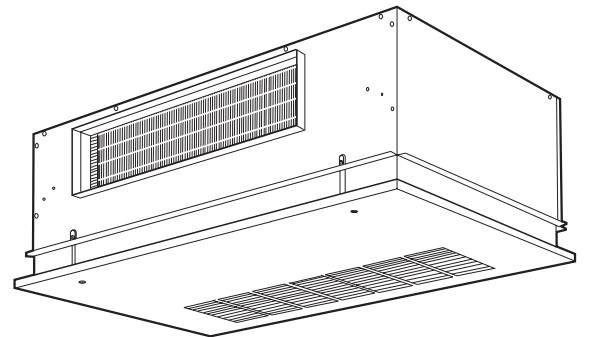

42CK
Cabinet model with telescoping flip-down panel and stamped louver bottom return or duct collar rear return.
(200-1200 cfm)

Features/Benefits (cont)

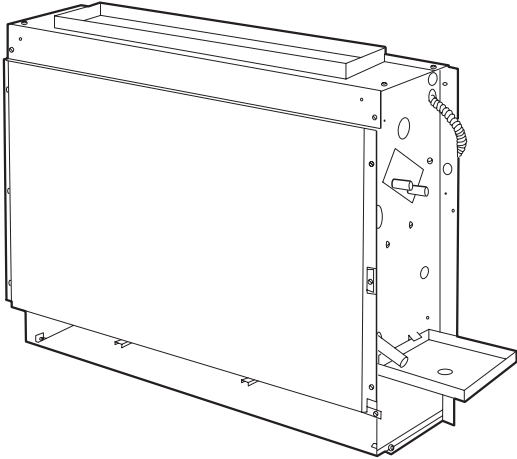

42VA
Furred-in model for under-the-window applications with top or front discharge. (200-1200 cfm)

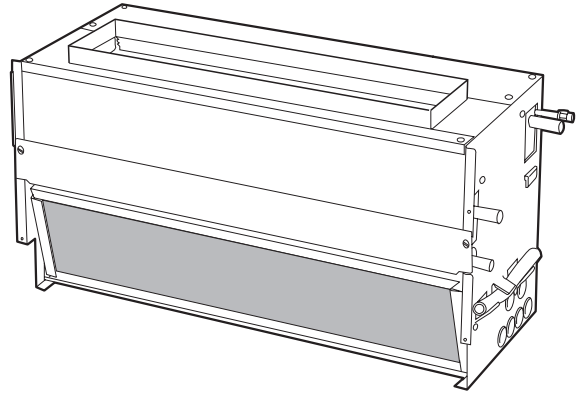

42VC
Furred-in loby model for concealed under-the-window applications. (200-600 cfm)

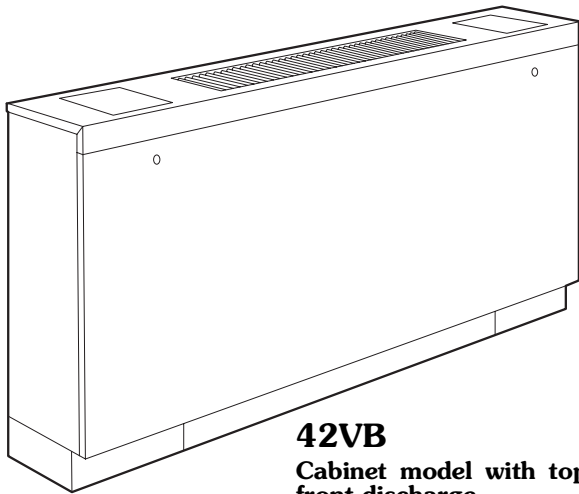

42VB
Cabinet model with top or front discharge. (200-1200 cfm)

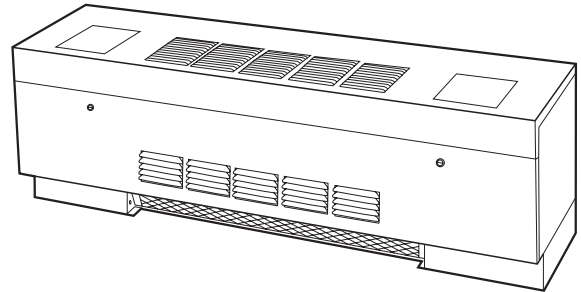

42VE
Cabinet loby model with stamped louver discharge grille and 2 control access doors. (200-600 cfm)

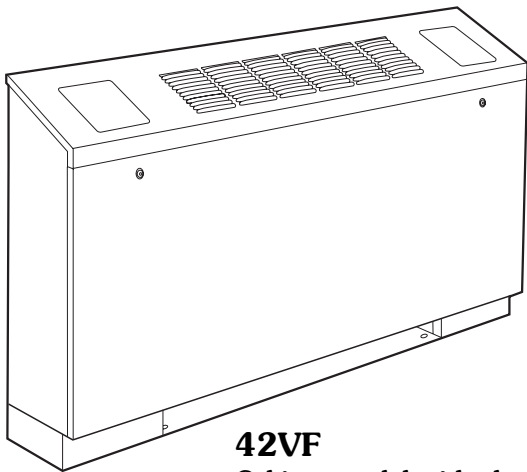

42VF
Cabinet model with slant top and top or front discharge. (200-1200 cfm)

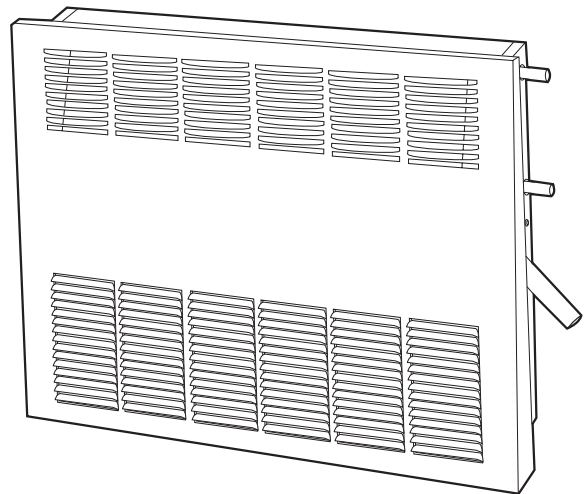

42VG
Furred-in wall model. Available with a 10-in. valve compartment extension. (150 and 300 cfm)

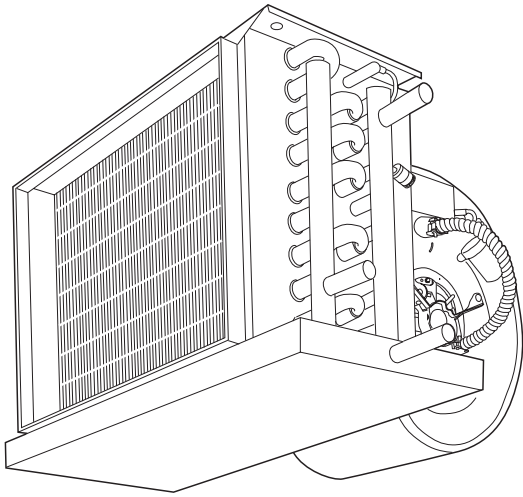

42DA
Furred-in model for installation in the ceiling or over the closet.

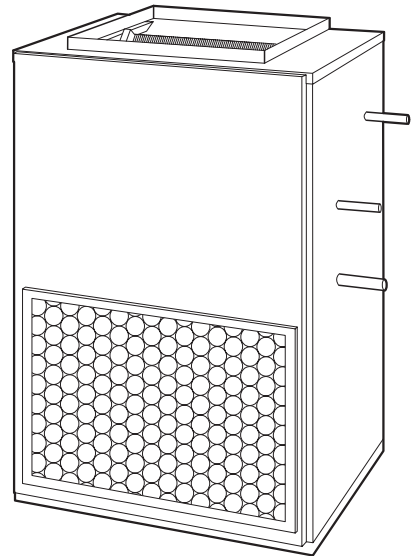

42DD
Vertical model with galvanized casing. Commonly for closet installation.

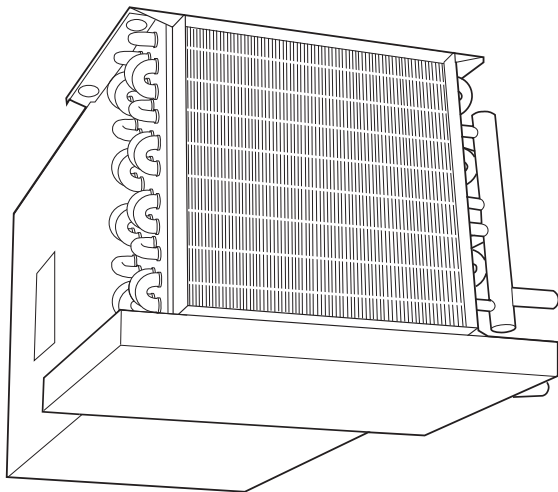

42DC
Furred-in ceiling model with factory-installed insulated plenum.

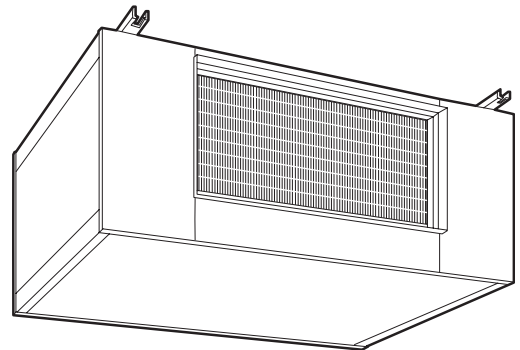

42DE
Ceiling model with galvanized casing.

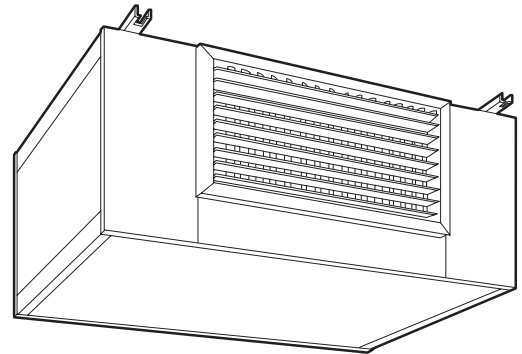

42DF
Exposed-ceiling cabinet model with integral double-deflection discharge grille and a bar-type return-air grille.

Features/Benefits (cont)



42SG — Furred-in-stack

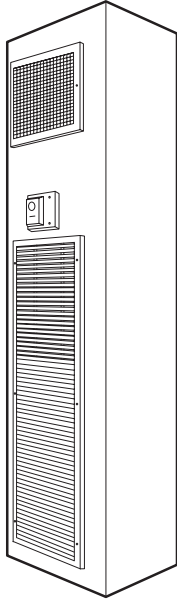

The furred-in-stack is a single unit, constructed of 18-gage galvanized steel designed for concealed applications in corners or along room walls. After installation of the unit, only the supply-air grille, room thermostat, and decorative return-air grille access panel are visible.

The return-air grille is removable to allow access for servicing major components. The grille is furnished in a arctic white-colored enamel-baked finish. Other colors are available.

The 42SG is also available in master/slave unit pairs. The pairs are actually 2 separate units shipped individually and installed and piped together in the field. The master unit includes risers with stubout for field piping connections to the slave unit which has no risers of its own.

42SJ — Back-to-back furred-in stack

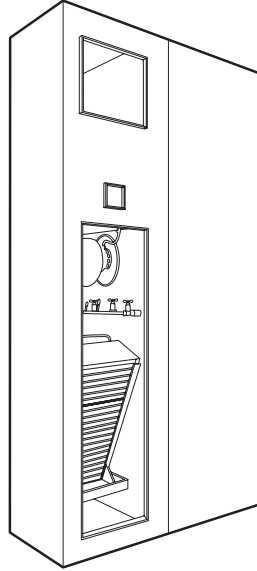

The back-to-back furred-in stack is designed for installation in the separation wall between 2 separate rooms. The unit is constructed of 18-gage galvanized steel. The unit consists of 2 separate units piped to a set of common risers. Each unit has its own valves and controls. After installation of the unit, only the supply-air grille, room thermostat, and decorative return-air grille panel are visible.

The return-air grille is removable to allow access for servicing major components. The grille is furnished in a arctic white-colored enamel-baked finish. Other colors are available.

42SH — Cabinet stack

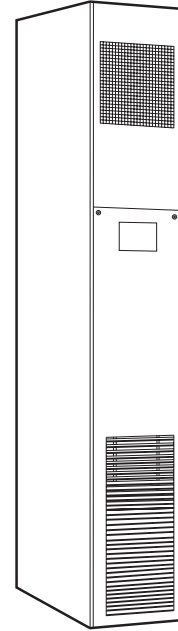

The cabinet stack unit is designed for applications where concealed installations are not possible or practical. The unit is constructed of 18-gage galvanized steel with a Arctic White-colored enamel-baked finish. This model features a double-deflection supply-air grille and an integral return-air grille access panel. Controls are normally mounted on the unit but may also be remote wall mounted.

Options and accessories



Factory-installed options

Coils — Choice of a 2-pipe or 4-pipe system with the following chilled/hot water coil configurations:

- 2-Row Coil (42VC, VE, VG only)
- 3-Row Coil - 42C, D, V, S
- 4-Row Coil - 42D, S
- 4-Row High Capacity - 42V, C, S
- 3-Row High Capacity - 42VC, VE
- 3/1 Opposite End Coil Connections - 42C series, 42VA, 42VB, 42VF
- 3/1 Same End Coil Connections - 42C series, 42VA, 42VB, 42VF, 42S
- 2/1 Same End Coil Connection - 42VC, VE
- 3/2 Opposite End Coil Connections - 42C series, 42VA, 42VB, 42VF, 42S
- 3/2 Same End Coil Connection - 42C series, 42VA, 42VB, 42VF
- 4/1 Opposite End Connections - 42D
- 4/1 Same End Connections - 42D, 42S
- 4/1 High Capacity Opposite End Coil - 42C series, 42VA, 42VB, 42VF
- 4/1 High Capacity Same End Coil - 42C series, 42VA, 42VB, 42VF
- 4/2 Same End Coil Connections - 42D
- 4/2 Opposite End Connections - 42D
- 6-Row High Capacity Coil - 42D
- 6/1 Opposite End Connection - 42DA, DC, DE, DF
- 6/1 Same End Connection - 42DA, DC, DE, DF
- 6/2 Opposite End Connections - 42DA, DC, DE, DF
- 6/2 Same End Connection - 42DA, DC, DE, DF

Decorator colors — A wide variety of colors (Champagne Beige, Toffee Brown, Ermine Grey, and Polar White) are available to match any interior décor. Select a desired color from a paint chip chart, Catalog number 842-011, or provide paint chip for matching. Standard color is now Arctic White; the other colors require a special quote. Decorative colors may be applied to:

- Cabinet of 42VB, VF, VE, VG
- Cabinet of 42CG
- Panels 42S
- Bottom Panels of 42CK
- Wall Panels of 42VA
- Cabinet 42DF

Electric heaters — Coils are of high grade single-phase, nichrome resistance wire, insulated by ceramic insulators in plated steel brackets. Heater sizes available are shown in the application data section for the respective units. Not available on 42VG units.

Filters — Each unit (except the 42CA, VG unit) includes a fiberglass throwaway filter sized for low velocity and maximum efficiency. The standard option will filter both return- and outside-air. Optional permanent aluminum filters with cleanable, non-aluminum filter media are available for 42CE, CF, CG, CK, DC, DD, DE, all 42V series, and all 42S series units.

Manual air vents — Each standard coil includes a manual air vent to allow venting at the coil if necessary for quick, complete air elimination.

Outside-air opening/damper — Damper is adjustable from 0 to 25% and provides ventilation air to unit. (Available on 42VA, VB, VF and 42S series units.)

Single power source connection — Provides factory-installed junction box to allow use of single power source for motor and heater when they are of the same voltage. For 42D and 42S series units.

Stamped toe space return-air grille — (42VB, VF units.)

Tamperproof “Camloc” fasteners — Camloc fasteners are installed on the access panels and are available for all cabinet model units.

Thermostat control packages — The standard thermostat control option is line voltage. Unit-Mounted line voltage and 24V thermostats are available on the 42V series units. For thermostat control package options refer to pages 10-12.

Field-installed accessories

Automatic air vents — Automatic air vents have fiber washers which allow air in the pipes to pass through, automatically bleeding the system, and eliminating the need to manually remove air from the system. When wet, washers swell and seal the system.

Decorative wall panels — Wall panels are available for use with fully recessed 42VA units.

Drip lips (removable drain extension) — Drip lips are frequently used when valves are added after unit installation and space limitations will not permit use of an extended drain pan. The drip lip is placed on the end of the drain pan and is pitched toward the pan to ensure proper drainage. The drip lip gives positive control of condensate from valves and controls on 42DA, DC units (available as an option on 42DE, DF units). Provided as standard on these units when factory-supplied motorized valve package is ordered. The drip lip is also installed on the 42C series ceiling fan coil units when 2-way or 3-way motorized valve packages are ordered.

Panels, frames, and grilles — Panels, frames, and grilles on the 42S series units can be chosen in a wide variety of combinations to suit room decorating requirements and allow access to the unit for maintenance. Discharge grilles are double deflection type, aluminum finish or painted. Return-air access panels containing return-air grilles are available in five different types as illustrated on page 97.

PANELS, FRAMES AND GRILLES

PANEL NO.	DESCRIPTION
1	Standard, 18-gage galvanized steel. Coated with baked-on Arctic White enamel finish. Attached to unit with 1/4 turn fasteners.
2	18-gage galvanized steel. Coated with baked-on Arctic White enamel finish. Includes access door for concealed unit-mounted controls.
3	Bar-type extruded aluminum with frame matching double deflection supply grille. Fastens to wall and unit with 1 1/2 in. long screws.
4 and 5	18-gage galvanized steel. Coated with baked-on Arctic White enamel finish. Frame mounted on sheetrock with screws. Panel mounted in frame with 1/4 turn fasteners.
All	Each panel provides access to all internal components.

Options and accessories (cont)



Return-air grilles — Stamped-type return-air grilles are standard on 42C, V, S units. Anodized aluminum hinged bar-type grilles are installed on 42CG, CK and DF (available as an option on 42DA, DC, DE, DD) units.

Risers — The 42S series units can accommodate 3/4-in. (supply and return) and 1-in. (drain) to 2 1/2-in. riser sizes in 2-pipe systems. For other applications, such as reverse return risers or 4-pipe systems, it may be necessary to accommodate the additional risers.

Condensate drains are available in sizes down to 1-in. for greater cost economy. Riser size-reducers are factory-installed and for risers of over 115-in. length, filler pieces can be furnished for field installation.

Riser expansion — When necessary, the 42S series units are provided with factory-installed expansion loops. These expansion loops provide up to 1 1/2-in. of riser expansion within the standard unit construction. This means that the unit can be used on installations of up to 20 floors without any additional expansion devices.

Risers material and insulation — The 42S series unit factory-installed supply, return, and drain risers can be furnished in type M or L copper. All factory-furnished risers are insulated with flexible closed foam insulation in 1/2-in. or 3/4-in. thickness.

Supply-air grilles — Two types of double deflection supply-air grilles are available for horizontal and vertical units; an integral steel grille painted to match the unit or a separate unpainted anodized aluminum grille. Not applicable to 42VG units.

Tell-tale drain pan — A secondary drain connection is located above the primary drain to act as a “tell-tale” in the event that the primary drain becomes obstructed. They can be applied to either the main drain pan or an extended main drain pan. This option only available on the 42C, 42V (except 42VG), and 42DA, DC, DE, DF.

Thermostat control packages — The standard thermostat control option is line voltage. Wall-mounted line voltage and 24-v thermostats are available on the 42 series fan coil units. 24-v thermostat is not available on the 42VC,VE,VG unit. Thermostat control packages options refer to page 10-12.

Trim strips — Strips are available for use with partially recessed vertical 42VA units and 42S only.

Wall boxes — Wall boxes are all aluminum with insect screen behind louvers. The wall boxes are available on all 42V series units except the 42VG units.

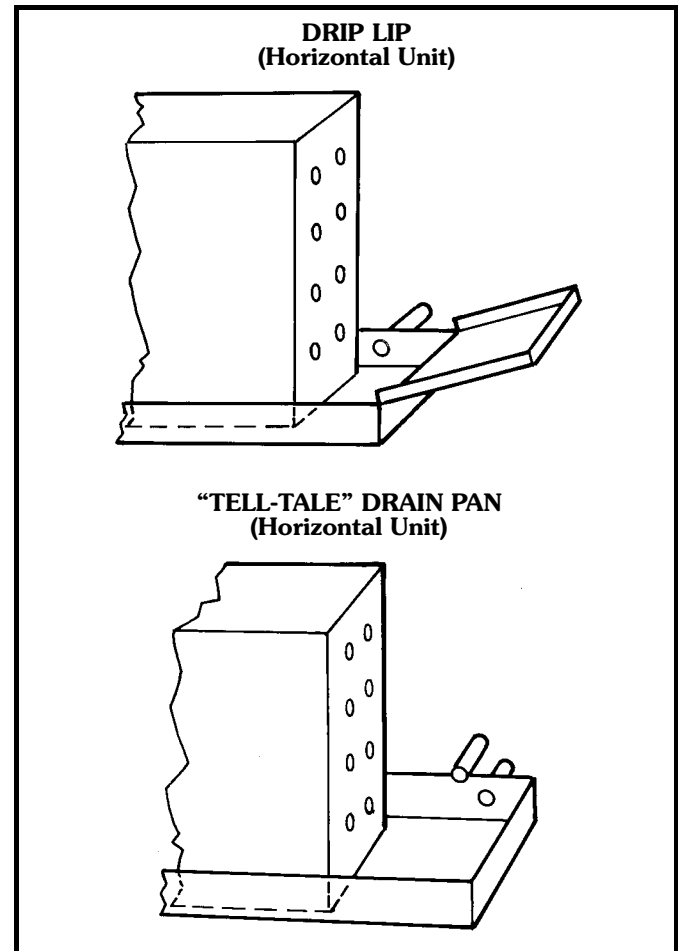



AVAILABLE OPTIONS AND ACCESSORIES

AVAILABLE FACTORY-INSTALLED OPTIONS AND FIELD-INSTALLED ACCESSORIES	UNIT SERIES — 42																		
	Ceiling — Horizontal					Floor — Vertical						Ducted — Horizontal					Stack — Vertical		
	CA	CE	CG	CK	CF	VA	VB	VF	VC	VE	VG	DA	DC	DE	DF	DD	SG	SH	SJ
AIR VENT																			
Automatic Air Vent	*	*	*	*	*	*	*	*	*	*	*	*	*	*	*	*	*	*	*
Manual Air Vent	Std	Std	Std	Std	Std	Std	Std	Std	Std	Std	Std	Std	Std	Std	Std	Std	Std	Std	
CABINET CHANGES																			
Front Panel, 16 Gage							*	*											
Front Panel, 18 Gage	Std	Std	Std	Std	Std	Std	Std	Std	Std	Std	Std	Std	Std	Std	Std	Std	Std	Std	
Extended Cabinet when Electric Heat or Valves are Installed								*	*										
Valve Compartment Extension, 10 in.										*									
Stamped Toe Space Return Grille							*	*											
COILS																			
2-Row (Cooling Only)									Std	Std	Std								
3-Row (2-Row Cooling, 1-Row Heating)									*	*									
3-Row (High-Capacity)	Std	Std	Std	Std	Std	Std	Std	Std	*	*		*	*	*	*	Std	Std	Std	
4-Row (3-Row Cooling, 1-Row Heating)	*	*	*	*	*	*	*	*				*	*	*	*	*	*	*	*
4-Row (High-Capacity)	*	*	*	*	*	*	*	*				Std	Std	Std	Std	Std	*	*	*
5-Row (4-Row Cooling, 1-Row Heating)	*	*	*	*	*	*	*	*	*	*		*	*	*	*	*	*	*	*
5-Row (3-Row Cooling, 2-Row Heating)	*	*	*	*	*	*	*	*	*	*		*	*	*	*	*	*	*	*
6-Row (4-Row Cooling, 2-Row Heating)												*	*	*	*	*	*	*	*
6-Row (High-Capacity)												*	*	*	*	*	*	*	*
7-Row (6-Row Cooling, 1-Row Heating)												*	*	*	*	*	*	*	*
8-Row (6-Row Cooling, 2-Row Heating)												*	*	*	*	*	*	*	*
DAMPERS																			
Manual — Adjustable through Return Air Opening						*	*	*									*	*	*
Manual Adjustment, Remote Mounted						*	*	*									*	*	*
Manual — Rear Opening with Sliding Damper — Not Filtered						*	*	*	*	*							*	*	*
Outdoor Air Connection (6 in.), with Filter and with or without Damper						*	*	*											
Damper, Linkage and Motor Wired to Auxiliary Contact of 3-Speed Switch						*	*	*											
DECORATIVE COLORS																			
(See Carrier Fan Coil Paint Selector Guide)			*	*		*	*	*		*	*			*		*	*	*	*
DISCHARGE GRILLES																			
Stamped Front Discharge			Std				Std	Std		Std	Std								
Double Deflection, Installed			*				*	*		*									
Double Deflection, Shipped Loose	*	*		*	*							Std	Std	Std	Std	Std	Std	Std	Std
DRAIN PANS																			
Sprayed on Closed-Cell Foam on Inside Main Drain Pan	Std	Std	Std	Std	Std	Std	Std	Std	Std	Std		Std	Std	Std	Std	Std	Std	Std	
Auxiliary Plastic Drain Pan						Std	Std	Std											
Auxiliary Steel Drain Pan									Std	Std									
Auxiliary Drip Lip — Included with 2- or 3-Way Motorized Valves	*	*	*	*	*							Std	Std	*	*				
Tell-Tale, with Second Drain Connection	*	*	*	*	*	*	*	*	*	*		*	*	*	*	*	*	*	*
Stainless Steel	*	*	*	*	*	*	*	*	*	*	*	*	*	*	*	*	*	*	*
DUCT COLLAR																			
Discharge	Std	Std	Std	Std	Std	Std	Std	Std	Std	Std		Std	Std	Std		Std	Std	Std	
ELECTRIC HEATERS																			
Nichrome Wire Strip Heater	*	*	*	*	*							*	*	*	*	*	*	*	*
Sheath Type Heater						*	*	*	*	*									
FAN SWITCH																			
Unit-Mounted, Wired and Installed							Std	Std		Std							Std	Std	Std
Wall-Mounted with Plate for Field-Mounting	Std	Std	Std	Std	Std	Std			Std		Std	Std	Std	Std	Std				
FILTERS																			
Permanent Filter		*	*	*	*	*	*	*	*	*		*	*		*	*	*	*	*
Throwaway Filter		Std	Std	Std	Std	Std	Std	Std	Std	Std									
LEVELING LEGS																			
INSULATION																			
Foil Faced Insulation	*	*	*	*	*	*	*	*	*	*	*	*	*	*	*	*	*	*	*
Tuf-Skin II	Std	Std	Std	Std	Std	Std	Std	Std	Std	Std	Std	Std	Std	Std	Std	Std	Std	Std	
Tuf-Skin RX Insulation	*	*	*	*	*	*	*	*	*	*	*	*	*	*	*	*	*	*	*
MOTORS																			
120-1-60, 3-Speed	Std	Std	Std	Std	Std	Std	Std	Std	Std	Std	Std	Std	Std	Std	Std	Std	Std	Std	
208-1-60, 3-Speed	*	*	*	*	*	*	*	*	*	*	*	*	*	*	*	*	*	*	*
230-1-60, 3-Speed	*	*	*	*	*	*	*	*	*	*	*	*	*	*	*	*	*	*	*
277-1-60, 3-Speed	*	*	*	*	*	*	*	*	*	*	*	*	*	*	*	*	*	*	*
220-1-50, 3-Speed	*	*	*	*	*	*	*	*	*	*	*	*	*	*	*	*	*	*	*
MOTOR QUICK-DISCONNECT PLUG	Std	Std	Std	Std	Std	Std	Std	Std	Std	Std		Std	Std	Std	Std	Std	Std	Std	
OUTSIDE-AIR WALL BOX							*	*	*										
RETURN AIR GRILLE, Shipped Loose																			
Stamped Return Grille	Std	Std	Std	Std	Std	Std	Std	Std	Std	Std	Std					Std	Std	Std	
Hinged Panel			Std	Std								*	*	*	Std	*			
TAMPERPROOF LOCKS (Camloc)																			
Access Panels						*	*	*		*	*						*	*	*
Access Doors						*	*	*		*	*						*	*	*
VALVE PACKAGES	*	*	*	*	*	*	*	*	*	*	*	*	*	*	*	*	*	*	*
WALL PANELS (for Recessed Unit)						*				*	*					*	*	*	*
WIRING PACKAGES	*	*	*	*	*	*	*	*	*	*	*	*	*	*	*	*	*	*	*

LEGEND

- * — Available as a Factory-Installed Option or a Field-Installed Accessory
- Std — Standard

Controls



Use the Control Selection guide to make sure that all necessary components are provided for and that the components are compatible with the required control system.

NOTE: When thermostatic fan control is selected or when unit outside air dampers are used, unit-mounted thermostats are not recommended as their use will result in poor room temperature sensing.

CONTROL SELECTION GUIDE

SYSTEM	DESCRIPTION	THERMOSTAT	CHANGEOVER ON SUPPLY PIPE	VALVE	FAN SWITCH (SW)	NOTES	
2-PIPE HEATING-COOLING*	Fan Control (2-Pipe)	Fan manually cycled	None	None	Standard 3-Speed SW	Not recommended for high humidity application	
		Thermostat cycles fan on-off from speed set with fan switch.	Wall mounted includes heat-cool switch.	None	Thermostat has integral 3-Speed SW		
		Thermostat cycles fan on-off from fan speed set with switch. Mode automatically switched by changeover sensing water temp.	Wall mounted. Heating/cooling Thermostat	Yes	None	Standard 3-Speed SW	Unit-mounted thermostats provide very poor room temperature control
		Thermostat cycles fan from high to low on cooling and low to off on heating.	Wall or unit mounted	Yes	None	No Standard 3-Speed Switch, ON-OFF toggle SW only	Best fan cycle control for high humidity applications
2-PIPE HEATING-COOLING*	Two-position electric valves (2-pipe)	Thermostat cycles valve open or closed.	Wall mounted includes heat-cool switch.	None	Motorized (N.C.) 3-way or 2-way, no bypass required.	Thermostat has integral 3-Speed SW	Valve packages with belled end(s) for field soldering to coil.
		Thermostat cycles valve open or closed. Mode automatically switched by changeover sensing water temp.	Wall or unit mounted. Heating/cooling Thermostat	Yes	Motorized (N.C.) 3-way or 2-way	Standard 3-Speed SW. Others have thermostats with integral 3-Speed SW	
ELECTRIC HEAT	Two-position electric valve with Auxiliary Electric Heat (2-pipe)	Thermostat cycles valve open or closed. 2° F after valve closes, thermostat activates electric heater. Heater cannot turn on if hot water is in coil.	Wall or unit mounted. Sequenced heating and cooling.	Yes. Two Required.	Motorized 3-way or 2-way	Standard 3-Speed SW. Others have thermostats with integral 3-Speed SW	Valve packages with belled end(s) for field soldering to coil.
		Thermostat cycles valve open or closed. Manual changeover switch changes thermostat to heat to activate electric heater.	Wall mounted includes heat-cool switch.	None	Motorized 3-way or 2-way, no bypass required	Thermostat has integral 3-Speed SW	Valve packages with belled end(s) for field soldering to coil.
	Two-position electric valve with total electric heat (2-pipe)	Thermostat cycles valve open or closed. Manual changeover switch changes thermostat to heat to activate electric heater.	Wall mounted includes heat-cool switch.	None	Motorized (N.C.) 3-way or 2-way, no bypass required	Thermostat has integral 3-Speed SW	Valve packages with belled end(s) for field soldering to coil.
		Thermostat cycles valve open or closed. 2° F after valve closes, thermostat activates electric heater.	Wall or unit mounted. Sequenced heating and cooling	None	Motorized (N.C.) 3-way or 2-way, no bypass required	Standard 3-Speed SW	
4-PIPE	Two-position electric valves (4-pipe)	Thermostat cycles cooling and heating valves open or closed.	Wall mounted includes subbase with heat-cool switch.	None	Motorized (N.C.) 3-way or 2-way (requires 2 valves)	Thermostat has integral 3-Speed SW	Valve packages with belled end(s) for field soldering to coil.
		Thermostat cycles cooling valve open or closed. 2° F after valve closes, thermostat cycles heating valve open or closed.	Wall or unit mounted. Sequenced heating and cooling.	None	Motorized (N.C.) 3-way or 2-way (requires 2 valves)	Standard 3-Speed SW. Others have thermostats with integral 3-Speed SW	

*If system is HEATING-ONLY or COOLING-ONLY, no changeover or bypass is required.

NOTE: Unit-mounted thermostats are not recommended with either fan-cycle control or applications with outside air dampers.

Remote-mounted controls



Standard 3-speed switch — This standard switch has 4 positions: OFF, HIGH, MEDIUM, and LOW. Switch has auxiliary contact that is energized when switch is in HIGH, MEDIUM or LOW position.

Some of the options common with the 3-speed switch are:

1. Unit-mounted switch on Furred-In Vertical Model. (Available as special order on Horizontal Models)
2. Switch without OFF position.
3. Key-operated switch.

Standard remote-mounted thermostat or optional unit-mounted thermostat

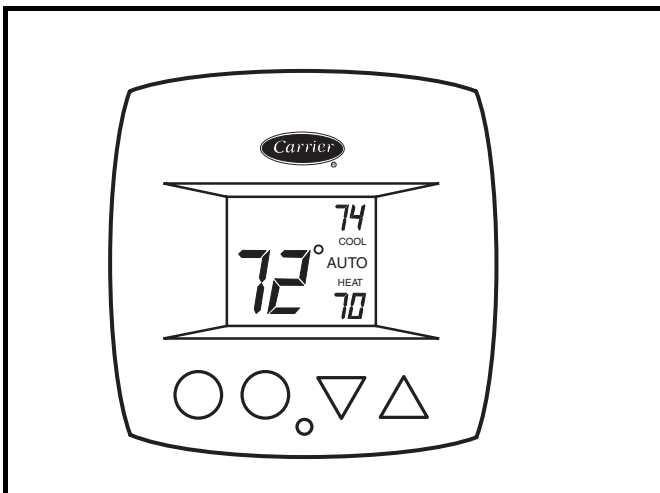

24-V Debonair® thermostat — Features large Thermoglow™ display, Neverlost™ memory, Exact Fit™ locking cover, Smart Fan™ dynamic fan speed control, 4-pipe, 2-pipe automatic changeover applications with adjustable dead band. Programmable and non-programmable models available.

Optional remote-mounted thermostat

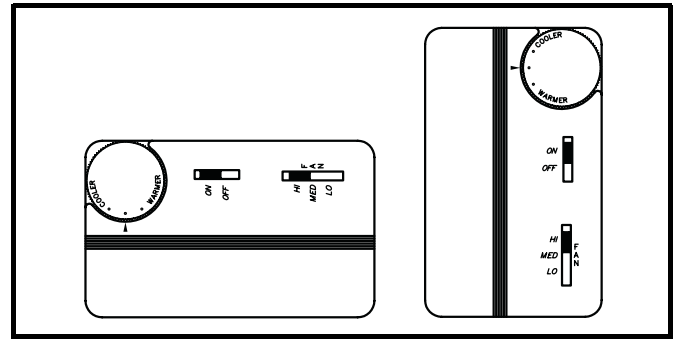

Line voltage T155 thermostat — Features 50 to 90 F temperature range, manual 3-speed fan control, mount is a standard 2 x 4 in. box, 4-pipe, 2-pipe and autochangeover applications. Available in vertical or horizontal styles.

Unit-mounted controls

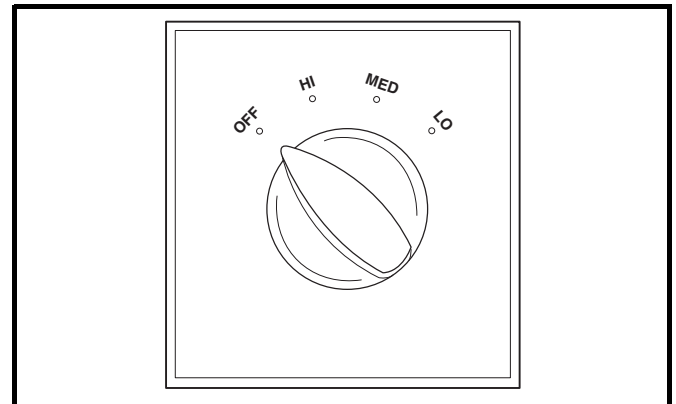

Standard 3-speed switch — Switch has OFF, HIGH, MED and LOW positions. Switch is also equipped with auxiliary connection energized when switch is in HIGH, MED or LOW position.

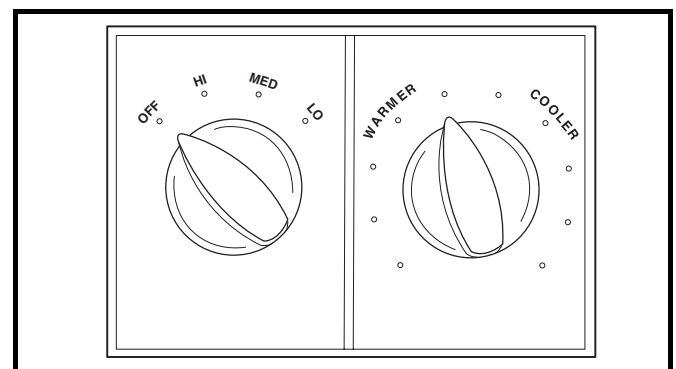

Combination thermostat/3-speed switch — Includes thermostat for 2-pipe or 4-pipe system and standard 3-speed switch. Thermostat and 3-speed switch are unit-mounted in a common electrical junction box. The special combination allows for the fan coil unit to have control for the valve cycle only.

Controls (cont)



Four-pipe thermostat, model TH104 — With this thermostat, heating and cooling are sequenced (automatic changeover) with 6 degree separation between HEATING ON and COOLING ON. The standard temperature range is 60 to 90 F.

Two-pipe thermostat, model TF103 — Single-pole double-throw (SPDT) thermostat has snap action contacts. The standard temperature range is 60 to 90 F.

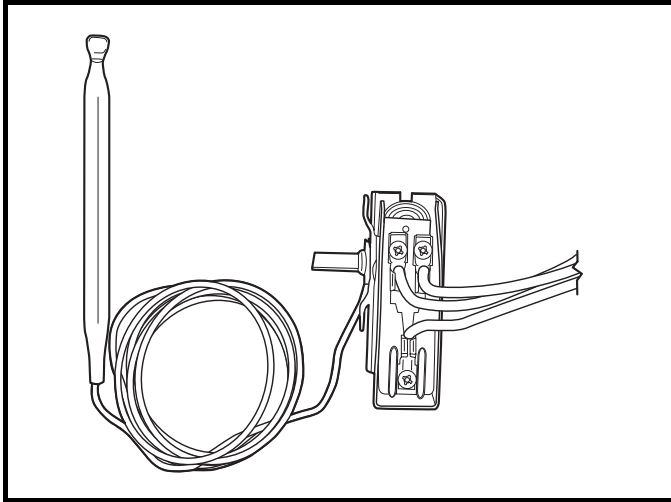

Automatic changeover (Summer-Winter switch) —

The automatic-changeover thermostat is a single-pole double-throw (SPDT) thermal switch in a moistureproof and dust-proof enclosure. Thermostat mechanism and lead ends are hermetically sealed in a polypropylene enclosure with epoxy resin. Device clamps on coil supply pipe with end snap-on clip.

The set point temperatures are factory set. When water temperature rises above 80 F (approximately), the thermostat switches to the winter cycle. When water temperature drops below approximately 70 F, the thermostat switches to the summer cycle. Switch reset is automatic.

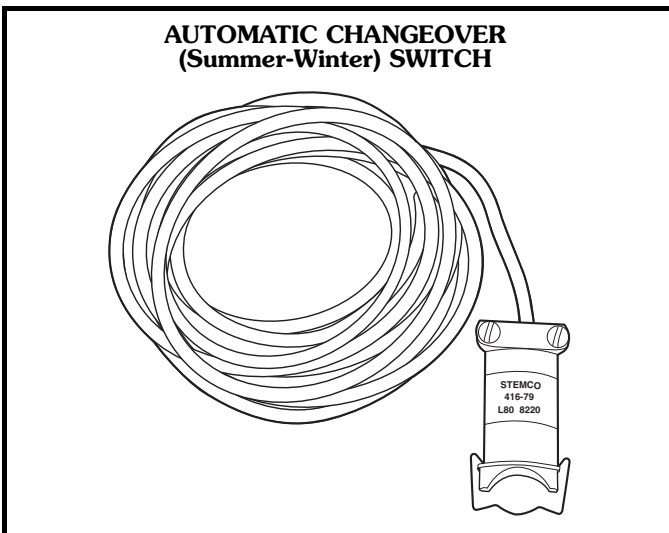

Fan coil control relay board — The fan coil relay board is used in conjunction with the Debonair thermostat or a CCN fan coil controller to regulate a single-speed or multi-speed fan. The fan coil relay board can also be used to connect the fan coil controller to a line voltage valve actuator.

The fan coil relay board is factory shipped as a PC board with four 1/2-in. stand-offs attached for field mounting.

NOTE: One fan coil relay board is used for each application. Fan coils with two or more fan motors use a fan coil relay board for each fan motor. A maximum of three fan coil relay boards can be wired to one fan coil control.

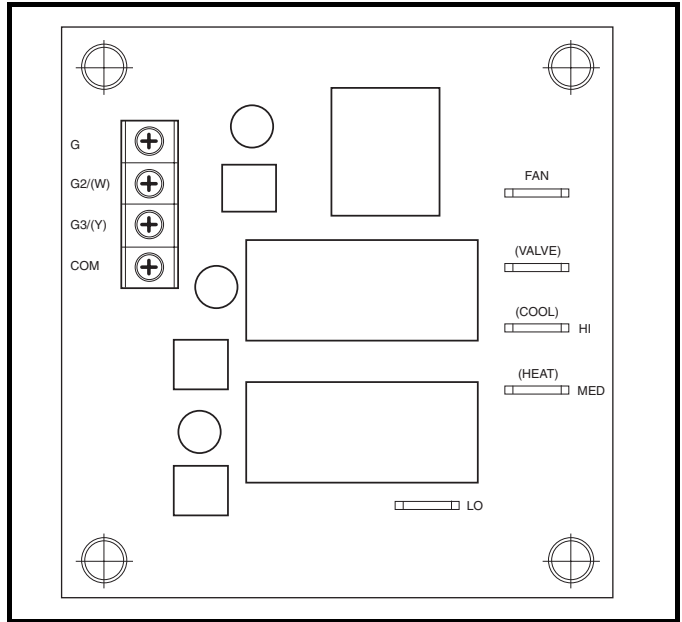

Application data



Basic definitions

Unit hand — When facing the supply air outlet from the front of the unit (air blowing in your face), your right hand will be the right hand side of the unit and your left hand the left hand side of the unit.

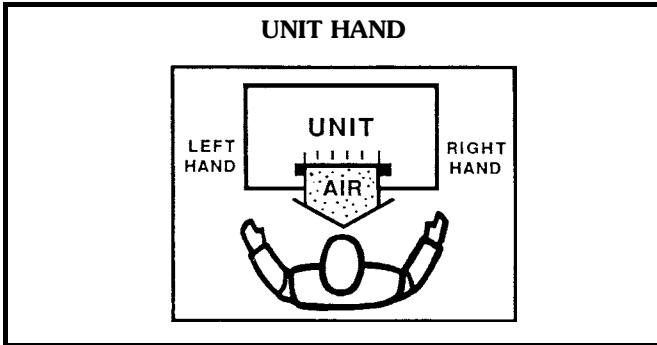

Same end connection (2 pipe or 4 pipe) — All piping connections are on the same end (side) of the unit. Controls and electrical connection will be on the end (side) opposite the piping connection.

Standard 2-pipe units will be the same end connection.

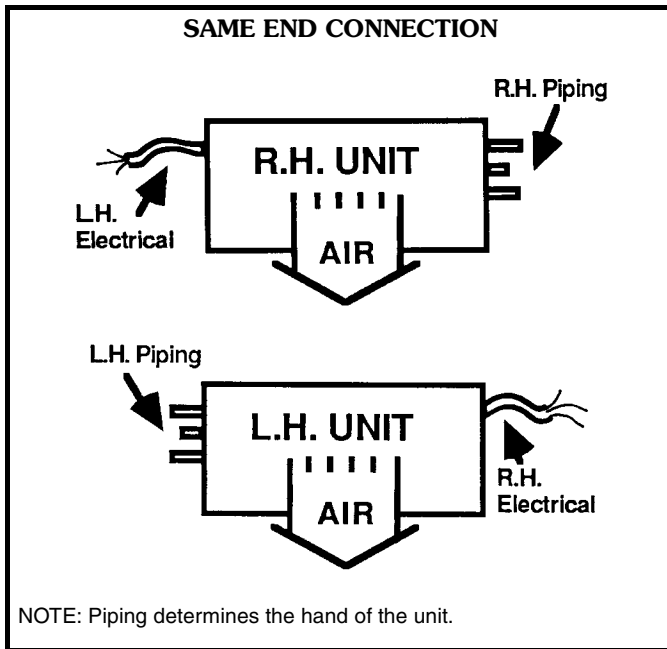

Opposite end connection (4-pipe option) — Hot water (HW) piping connections and electrical will be on the end (side) opposite the chilled water (CW) and drain connections.

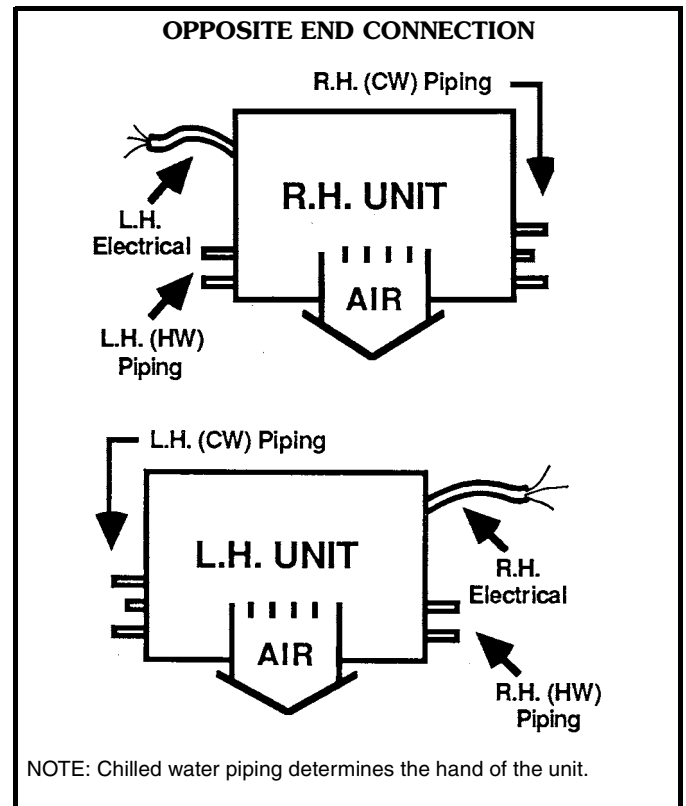

Application data (cont)



System piping

The following diagrams show some common methods used to pipe the 42S series units. Only the 2-pipe systems are shown; however, the methods would be the same for 4-pipe systems.

System 1, the “direct return” system, is the most common. It is economical to install since it supplies and returns the water for a riser column from the same location, at the top or the bottom of a building. This type of riser arrangement does require more attention to individual unit water flow balancing. The risers are normally capped at the end as shown in the diagrams.

System 2, the “reverse return” system, is used to minimize the requirement for individual unit balancing. This system is usually referred to as the self-balancing system. The arrangement of the risers allows the water flow for each unit in a column to be equalized. In the reverse return system both the supply and return mains are located at the top or the bottom of a building requiring an additional return riser to be furnished in the units.

System 3, the “common reverse return” system, typically has the supply and return mains located remotely from each other — such as one at the top and one at the bottom of a building. This eliminates the need for a reverse return riser in the units.

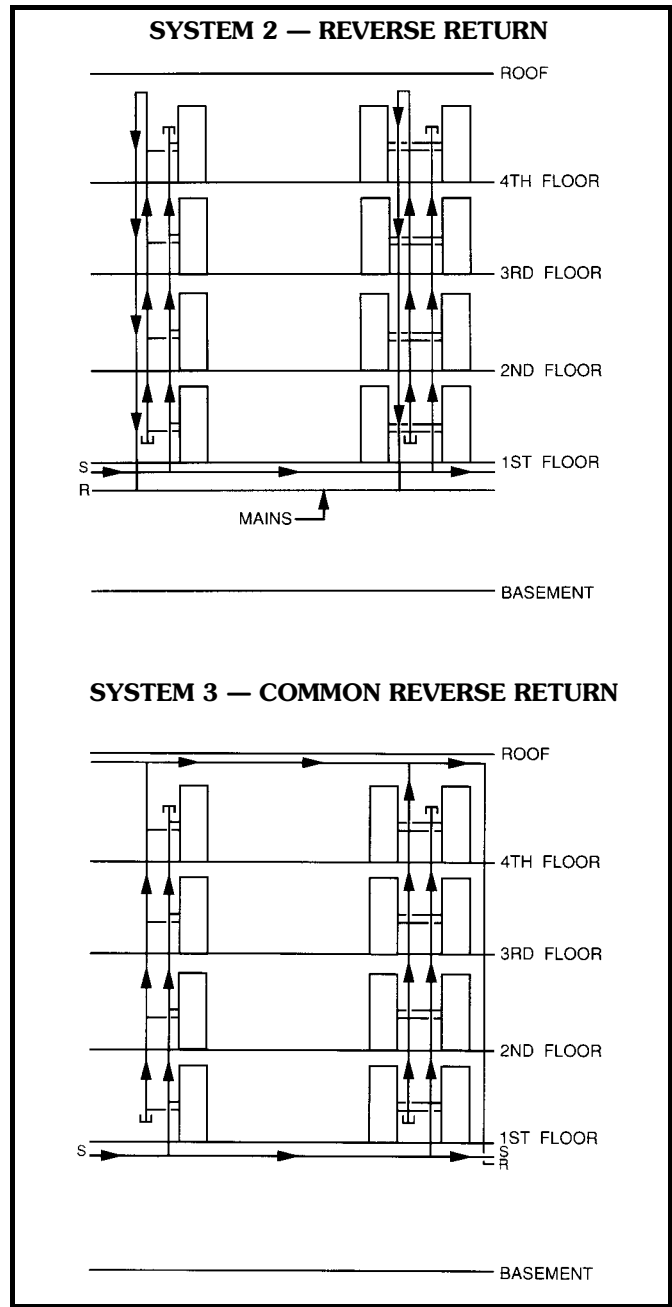
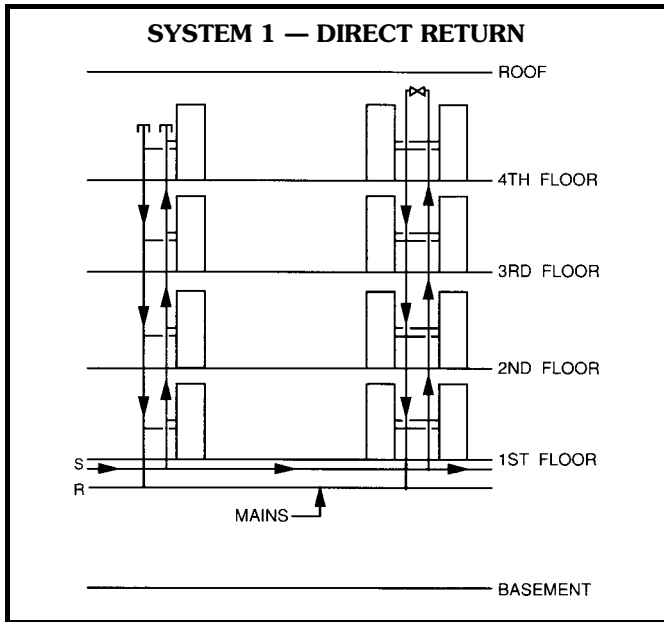

Risers

Riser diameter is an important consideration in the design of stack series systems. Standard units can accommodate 3/4-in. to 2 1/2-in. riser sizes in 2-pipe systems. For other applications, such as reverse return risers or 4-pipe systems, it may be necessary to accommodate the additional risers.

Riser size is based on the water flow needed for a given tier of units. Unit risers are sized according to the diameter and length requirements as specified by the customer. To determine riser size, water velocity should be limited to 5 to 8 ft/second. Thus, if 10 units are to be stacked vertically with each unit requiring 3 gpm, the maximum flow in the risers is 30 gpm. Through 1 1/4 in. risers, this is a velocity of 7.5 ft/second. The maximum flow rate of 30 gpm occurs only at the supply and return points. As the water moves upward, the flow in the supply riser is reduced by 3 gpm per floor, so that after 3 floors, the total flow is 21 gpm and riser size can be reduced to one inch. See chart on page 103.

Condensate drains are available in sizes down to one inch for greater first cost economy.

Riser size-reducers are factory installed and caps are provided at customer request.

For risers of over 115 in. length, filler pieces can be furnished for field installation.

Typical arrangements



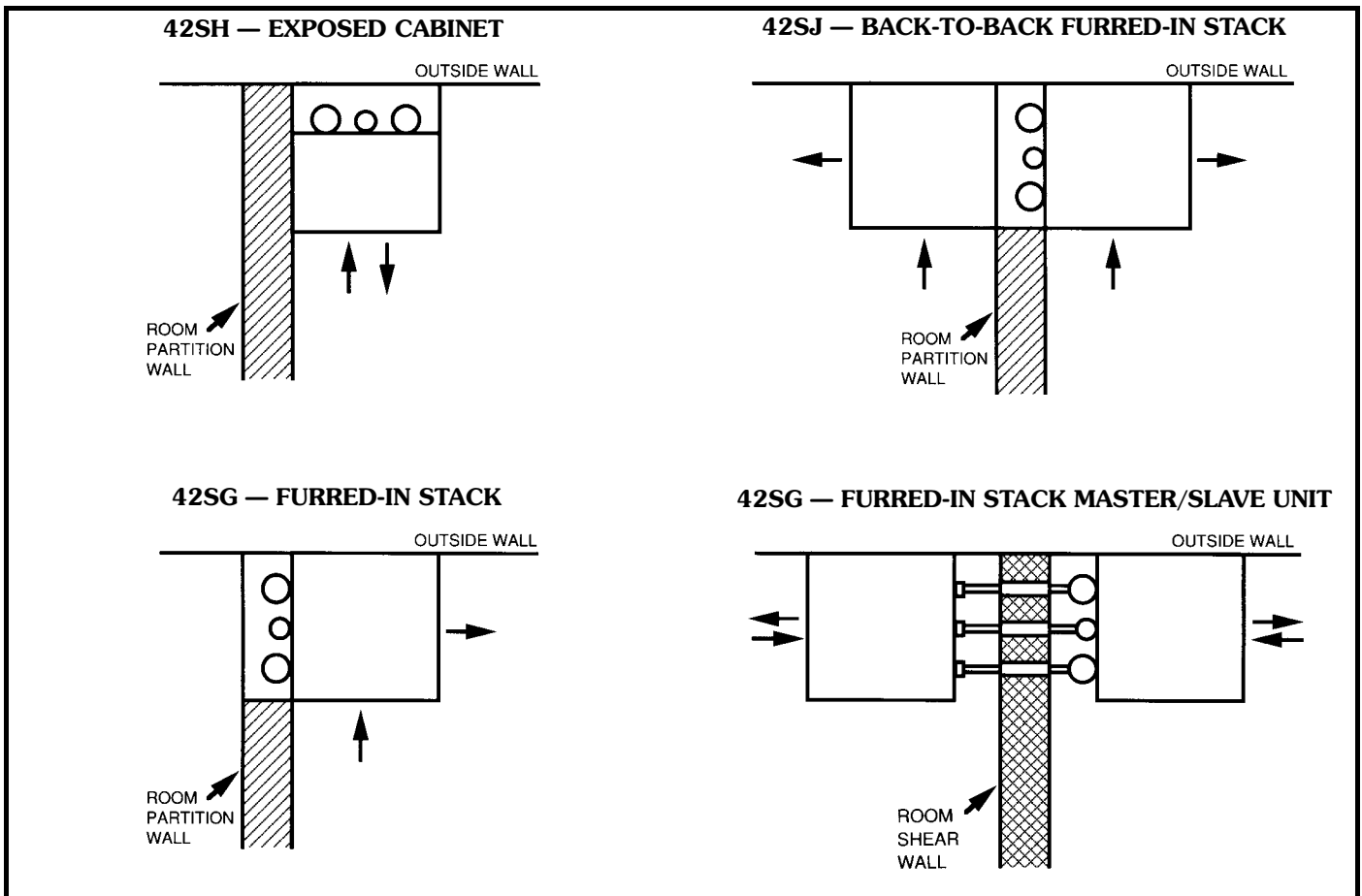





Typical arrangement applications for each model type are shown below. The fan coil units feature almost an unlimited number of arrangements to meet the needs of new construction, renovation, or reconstruction. Consult the factory for the arrangement (standard or special) to meet your particular need.

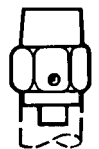

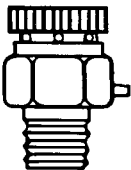
Application data (cont)

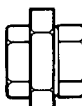

PIPING COMPONENTS

SYMBOL/SKETCH	DESCRIPTION	C _v FACTOR		RATING*		STEAM USE
		1/2	3/4	PSI	F	
 	<p>MANUAL AIR VENT: Threaded brass needle valve with screwdriver slot for adjustment.</p> <p>Application — Body brazed into high point of heating and cooling coils for bleeding air from coil. Standard item on all hydronic coils (not used on steam or DX coils). Should not be used in lieu of main system air vents.</p>	N/A	N/A	400	100	NO
 	<p>AUTOMATIC AIR VENT: Nickel plated brass valve, fiber-disc type, with positive shut-off ballcheck and quick vent feature via knurled vent screw.</p> <p>Application — Optional replacement for manual air vent. Automatically passes minute quantities of air through the fiber discs which expand upon contact with water, completely sealing the valve. As air accumulates, the fiber discs dry and shrink, repeating the cycle. Not recommended for removing large quantities of air encountered during initial start-up or subsequent draining and refilling. Should not be used in lieu of main system air vents.</p>	N/A	N/A	125	240	NO
 	<p>SWAGE: Copper tube end expanded to accept a copper tube of the same size for factory or field brazing.</p> <p>Application — Used where possible for all tubing joints for best joint integrity.</p>	N/A	N/A	300	200	YES
 	<p>UNION: Combination wrought copper/cast brass union assembly, solder by solder.</p> <p>Application — Used for quick connect (and disconnect) of valve package components to minimize field labor and facilitate servicing of unit.</p>	N/A	N/A	300	200	YES
 	<p>INSERTION TEST PORT: Brass body valve for acceptance of test probe (up to 1/8 in. diameter).</p> <p>Application — Installed on one (or both) sides of the coil to allow for temperature or pressure sensing. Used for close tolerance water balancing and service analysis.</p>	N/A	N/A	250	250	NO

LEGEND

C_v — Coefficient of Velocity
DX — Direct Expansion

*Check all system component pressure ratings (coils, valves, pumps, etc.) with manufacturer and any applicable local or national piping codes prior to specifying system pressure rating.

PIPING COMPONENTS (cont)

SYMBOL/SKETCH	DESCRIPTION	C _v FACTOR		RATING		STEAM USE
		1/2	3/4	PSI	F	
	<p>PRESSURE TEST PORT: Brass body 1/4 service access fitting with removable depressor type core.</p> <p>Application — Installed on both sides of the coil to allow for pressure sensing. Attach pressure gages to facilitate close tolerance water balancing.</p>	N/A	N/A	400	210	NO
	<p>GAGE COCK: Brass shut-off valve with 1/4 FPT fitting for attachment of pressure gages.</p> <p>Application — Installed on both sides of the coil to allow for pressure sensing. Attach pressure gages to facilitate close tolerance water balancing. May be used in bleed bypass line to regulate water flow.</p>	N/A	N/A	200	250	N/A
	<p>CIRCUIT SETTER: Variable water flow balancing valve with manual adjustment knob, pointer, percent-open scale, memory stop and integral pressure read-out ports.</p> <p>Application — Used for close tolerance water flow balancing. Positive shut-off ball valve feature allows usage as combination balancing and shut-off valve.</p>	2.12	3.9	300	250	NO
	<p>BALANCE VALVE: Variable water flow manual balancing valve with screwdriver slot adjustment screw.</p> <p>Application — Often used in conjunction with test port fittings for water flow balancing. Balance by temperature differential or coil pressure drop (check specifications for service fittings required if balancing by pressure drop). May be used in 3-way valve bypass line to permit equal flow balancing.</p>	3.0	8.9	150	200	NO
	<p>FIXED FLOW VALVE: Flexible orifice type (non-adjustable).</p> <p>Application — Used for water flow balancing. Valve automatically adjusts the flow to within 10% of set point. Requires 15 psi (35 ft) of additional pump head for proper operation.</p>	Valve orifice size determines C _v factor. The orifice of these fixed flow valves changes as flow is regulated. As the water pressure increases, the orifice size decreases, thereby automatically limiting the flow rate to the specified gpm (±10%).		150	160	NO









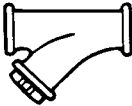

LEGEND

C_v — Coefficient of Velocity
 DX — Direct Expansion

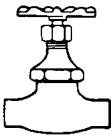
Application data (cont)

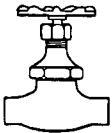



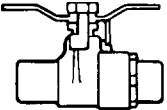

PIPING COMPONENTS (cont)

SYMBOL/SKETCH	DESCRIPTION	C _v FACTOR		RATING		STEAM USE
		1/2	3/4	PSI	F	
 	<p>STRAINER: Y-type body with 50 mesh stainless steel screen.</p> <p>Application — Used for removal of small particles from system water during normal system operation. Should not be used in lieu of main system strainers. Strainer screen may have to be removed during initial high pressure system flushing during start-up. Screen should be removed and cleaned per normal maintenance schedule (provisions for strainer blow-down not provided).</p>	9.0 Clean	19.0 Clean	400	250	N/A
 	<p>GATE VALVE: Manual shut-off valve.</p> <p>Application — Used for unit isolation during system flushing, servicing, etc. Do not use for water balancing.</p>	19.8	36.0	200	200	NO
 	<p>GLOBE VALVE: Standard pattern, manual shut-off and throttling valve.</p> <p>Application — Used for unit isolation. Not recommended for high flow rates due to relatively high pressure drop.</p>	1.8	3.9	200	200	NO
 	<p>COMPRESSION STOP VALVE: Manual shut-off valve.</p> <p>Application — Used for unit isolation during system flushing, servicing, etc. Not recommended for high flow rates due to relatively high pressure drop.</p>	2.3	5.4	150	200	NO
 	<p>BALL VALVE: Manual balance and shut-off valve.</p> <p>Application — Used for unit isolation and water flow balancing. Without memory stop feature water balance point must be marked by installer (if necessary). Check specifications for service fittings required when used for water balancing.</p>	4.0	7.5	400	200	YES
 	<p>BALL VALVE WITH MEMORY STOP: Manual balance and shut-off valve.</p> <p>Application — Used for unit isolation and water flow balancing. The adjustable memory stop feature allows return to the balance point after shut-off. Check specifications for service fittings required when used for water balancing.</p>	4.0	7.5	400	200	N/A

LEGEND

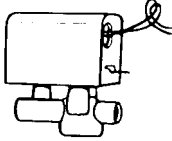
C_v — Coefficient of Velocity
 DX — Direct Expansion

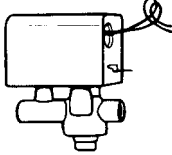
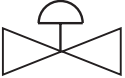
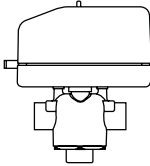
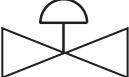
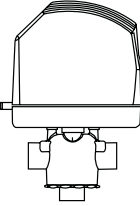
PIPING COMPONENTS (cont)

SYMBOL/SKETCH	DESCRIPTION	C _v FACTOR		RATING		STEAM USE
		1/2	3/4	PSI	F	
 	<p>2-WAY MOTORIZED VALVE: Electric 2-position flow control valve (open/closed). Normally closed body with manual override lever. Installed in supply line to unit.</p> <p>Application — All standard control and valve packages are based upon normally closed valves (valve electrically powered open and closed by spring return when electric power removed). Manual override lever allows valve to be placed in the open position for secondary (unit) flushing, constant water flow prior to start-up, etc. Manual override is automatically disengaged when valve is electrically activated. Consult factory for normally open valve applications.</p>	2.3	2.3	300	200	YES 15 PSI MAX.
 	<p>3-WAY MOTORIZED VALVE: Electric 2-position flow control valve (closed to coil/ open to bypass or open to coil/closed to bypass). Normally closed with manual override lever. Installed in supply line to unit.</p> <p>Application — Same comments as 2-way motorized valve except with manual override lever engaged the valve is open to both ports and water flow will take the path of least resistance through the valve package (not necessarily 100% through the coil).</p>	5.0 SERVICE 2.8 BYPASS	5.0 2.8	300	200	N/A
 	<p>MODULATING VALVE (Non-Spring Return): Modulating valves are designed to control the flow in the circuit by making incremental adjustments to the flow path within the valve.</p> <p>Application — To control fluid flow in fan coil units.</p>	4.0		300	200	N/A
 	<p>MODULATING VALVE (Spring Return): Modulating valves are designed to control the flow in the circuit by making incremental adjustments to the flow path within the valve.</p> <p>Application — Same comments as non-spring return except when powered, the actuator moves to the desired position, at the same time tensing the spring return system. When power is removed for more than two minutes the spring returns the actuator to the normal position.</p>	4.0		300	200	N/A
 	<p>AQUASTAT: Water temperature sensing electrical switch.</p> <p>Application — Clips directly on nominal size 1/2 in. or 3/4 in. copper tubing for water temperature sensing. Must be correctly located for proper control operation.</p>					

LEGEND

C_v — Coefficient of Velocity
DX — Direct Expansion

NOTES:

1. Motorized 2-way valves have a maximum close-off differential of 25 psi.
2. Motorized 3-way valves have a maximum close-off differential of 10 psi.

Application data (cont)



Valve packages

There are limitations on physical size of pneumatic valves, quantity and type of matching components, and required control interface. See Symbols and Placement of Valves diagram.

Consult factory before ordering any special valve package components that are not covered in this book.

Valve packages are shipped with the units or in unit cartons. Valve packages include belled ends for field soldering to coil connections.

All factory-furnished cooling valve packages are arranged to position as much of the package as possible over an auxiliary drain pan or drip lip. This helps minimize field piping insulation requirements.

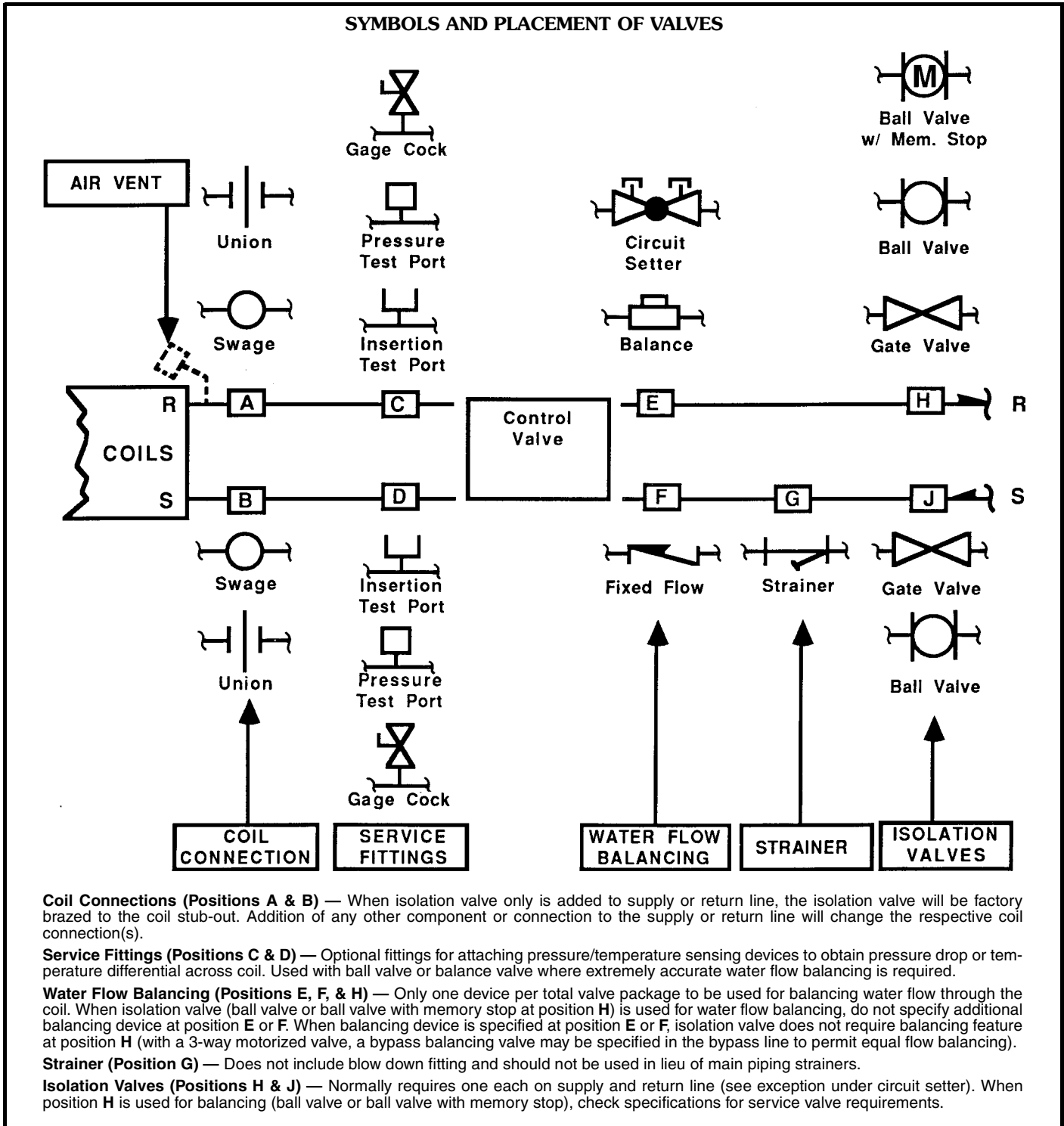

VALVE PACKAGE ARRANGEMENTS

WITH HAND VALVES ONLY

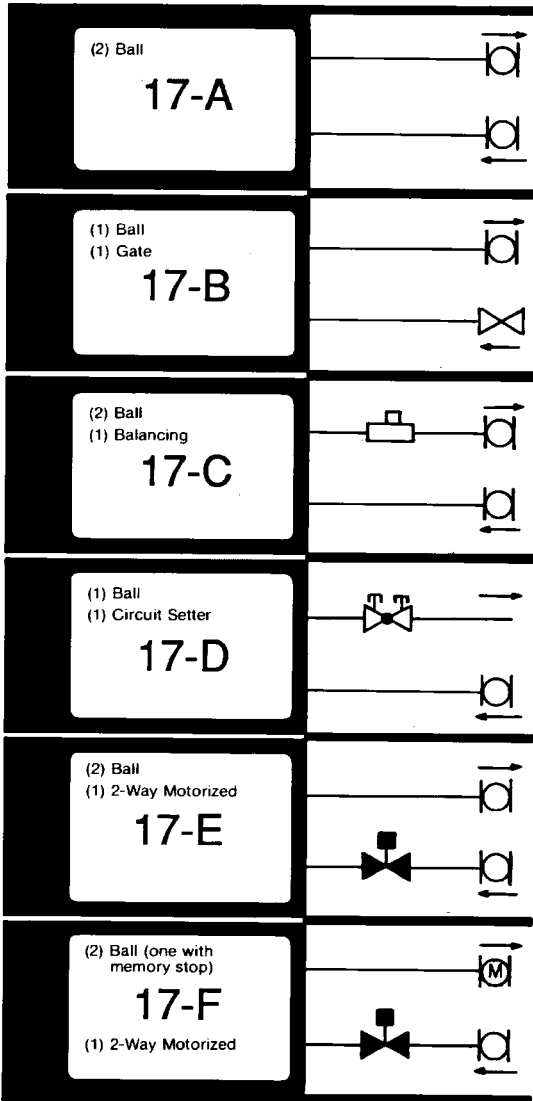

WITH MOTORIZED 3-WAY 2-POSITION VALVES

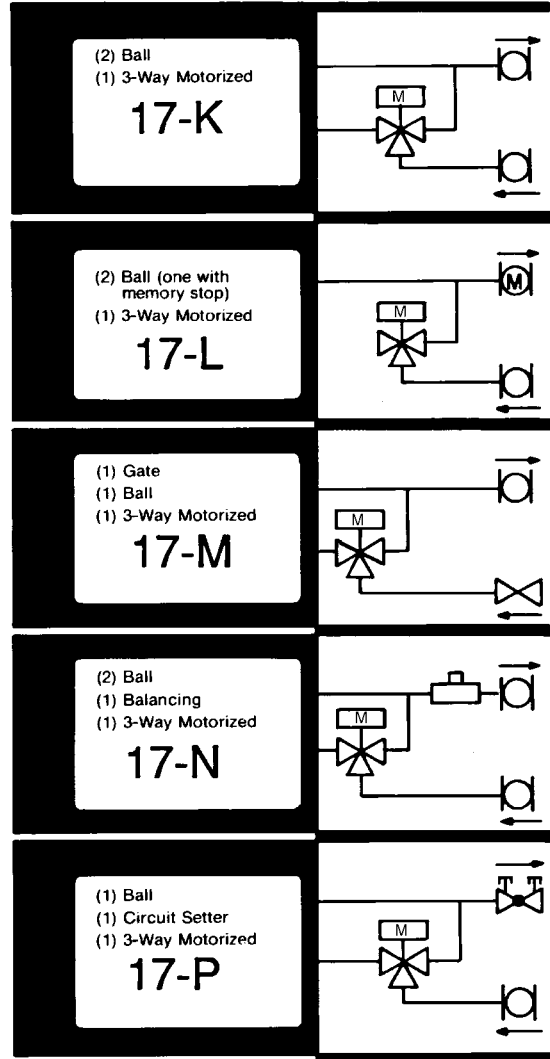

WITH MOTORIZED 2-WAY, 2-POSITION VALVES

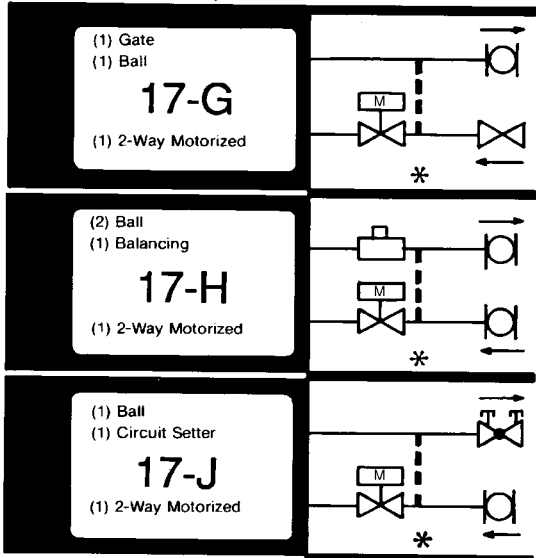

LEGEND

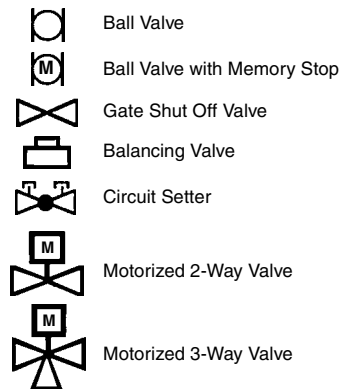

*When aquastat is used for automatic changeover, bypass is required as indicated by dashed line.

NOTES:

1. Packages factory furnished and installed.
2. Valves are 5/8-in. ODS unless otherwise specified.
3. If an automatic flow control valve is added, it will be located on supply line between shutoff valve and coil (or motorized control valve, if supplied).
4. Packages 17-A,B,C,D,E,F,G,H,J,K,L,M,N and P are listed on current price pages.

C_v FACTOR VS WATER PRESSURE DROP

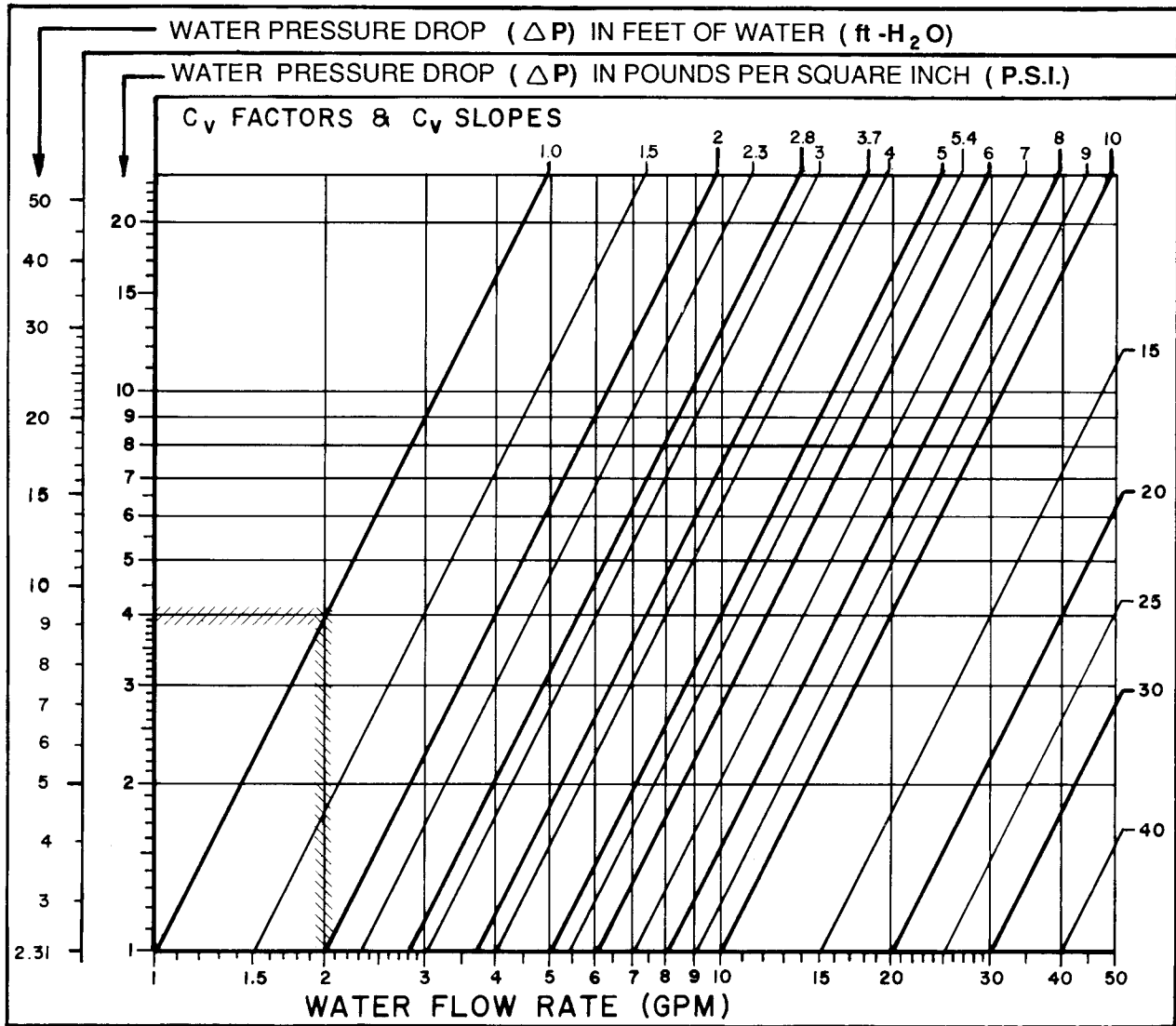

C_v FACTOR:

The flow rate in gallons per minute (gpm) through a piping component when the pressure drop (ΔP) in pounds per square inch (psi) across the component is 1.0 (psi).

$$\text{Pressure drop (ft-H}_2\text{O)} = 2.31 \times \text{psi (pressure drop)}$$

GRAPH EXAMPLE:

ΔP for 2.0 gpm through a component with a C_v of 1.0 is 4.0 psi x 2.31 = 9.24 ft-H₂O

FORMULA EXAMPLE:

$$\Delta P \text{ (ft-H}_2\text{O)} = \frac{(\text{gpm})^2}{(\text{C}_v)^2} \times 2.31 = \frac{(2.0)^2}{(1.0)^2} \times 2.31 = 9.24 \text{ ft-H}_2\text{O}$$

TOTAL PRESSURE DROP is the **Sum** of the pressure drop of all piping and components in the water flow path.



ENTHALPY AT SATURATION

TEMPERATURE (F)	ENTHALPY AT SATURATION (Btu per lb. of dry air)	TEMPERATURE (F)	ENTHALPY AT SATURATION (Btu per lb. of dry air)
40	15.230	60	26.46
41	15.697	61	27.15
42	16.172	62	27.85
43	16.657	63	28.57
44	17.149	64	29.31
45	17.650	65	30.06
46	18.161	66	30.83
47	18.680	67	31.62
48	19.211	68	32.42
49	19.751	69	33.25
50	20.301	70	34.09
51	20.862	71	34.95
52	21.436	72	35.83
53	22.020	73	36.74
54	22.615	74	37.66
55	23.22	75	38.61
56	23.84	76	39.57
57	24.48	77	40.57
58	25.12	78	41.58
59	25.78	79	42.62
		80	43.69

ALTITUDE COOLING CORRECTION FACTORS

ELEVATION (ft)	TOTAL HEAT	SENSIBLE HEAT
1000	.990	.960
2000	.980	.930
3000	.970	.896
4000	.960	.864
5000	.940	.830
6000	.930	.800
7000	.920	.770
8000	.910	.750
9000	.900	.730

STEAM PRESSURE CORRECTION FACTORS

ENTERING AIR TEMP (F)	STEAM PRESSURE (PSIG)	
	2	5
40	1.202	1.265
50	1.134	1.196
60	1.067	1.125
70	1.000	1.054

NOTE: Steam Heating Capacity (Btu/h) = Base Capacity x Pressure Correction Factor x SH (SH value found in Cooling Capacity Correction Factors table on page 60).

AIRFLOW CORRECTION FACTORS

CFM RATIO (Actual/Base)	TOTAL (Ct)	SENSIBLE (Cs)
1.40	1.25	1.26
1.35	1.22	1.23
1.30	1.19	1.20
1.25	1.16	1.17
1.20	1.13	1.14
1.15	1.10	1.11
1.10	1.07	1.08
1.05	1.04	1.04
1.00	1.00	1.00
0.95	0.97	0.97
0.90	0.94	0.93
0.85	0.90	0.89
0.80	0.86	0.85
0.75	0.82	0.81
0.70	0.78	0.77
0.65	0.74	0.72
0.60	0.70	0.67
0.55	0.66	0.62
0.50	0.62	0.57
0.45	0.58	0.52
0.40	0.53	0.47
0.35	0.48	0.42
0.30	0.43	0.38
0.25	0.38	0.33

LEGEND

- CFM — Cubic Feet per Minute
- Cs — Sensible Airflow Correction Factor
- Ct — Total Airflow Correction Factor
- ESP — External Static Pressure

Application data (cont)



Electric heat

Electric heaters are available for installation on Carrier fan coil units in the following applications.

Total electric heat — This system provides complete heating during the heating season; no boiler is required. Heating and cooling are now available on an individual basis throughout the year with a 2-pipe system.

Chilled water is used for cooling and the electric heater is used for heating. Individual room controls can be supplied for either manual or automatic changeover.

Auxiliary electric heat — This system is used for heating between seasons or during the cooling season when chilled water is being circulated. Individual room controls are supplied to provide electric heat only when chilled water is being circulated through the system. Water flow through the unit is shut off when the heater is turned on.

During the winter heating season, heating is provided by hot water circulated through the system. A changeover device locks out the electric heat when the hot water is circulated.

Heater construction

Strip heaters are used with Model 42C ceiling units, Model 42D ducted units and Model 42S stack units.

These heaters consist of coils of the highest grade resistance wire, insulated by ceramic insulators in aluminized brackets.

All heaters except those used in 42S stack units are positioned on the incoming (preheat) side of the unit coil.

42S stack units, the strip heater is located in the fan discharge on the leaving side of the coil.

Sheath heaters are used with Model 42V vertical units. These heaters consist of the highest grade resistance wire, centered in a 1/2-in. diameter copper-plated steel sheath. The wire is insulated from the sheath by magnesium oxide powder packed around it. To increase the heater surface exposed to air, a 1 1/4-in. OD fin of copper-plated steel is wound around the sheath in a continuous spiral that makes 5 turns per lineal inch. Sheath and fin are permanently bonded together by copper brazing.

The heaters are positioned on the leaving (reheat) side of the unit coil. On special units with high efficiency motors, a strip heater will be installed in the fan discharge on the incoming (preheat) side of the unit coil.

Heater electrical data

1. Load voltage may be 120, 208, 240 or 277 volts. For unit size and kW limitations, refer to the specific unit catalogs.
2. All heaters are single stage and single phase.
3. Unless a single power-source option is selected, the electric heat units require 2 separate power sources. With the single power-source option, only one line circuit need be brought into the unit. Fuse protection is added to the motor/control circuit to protect these components. This is separate from the field-furnished total unit overcurrent protection.

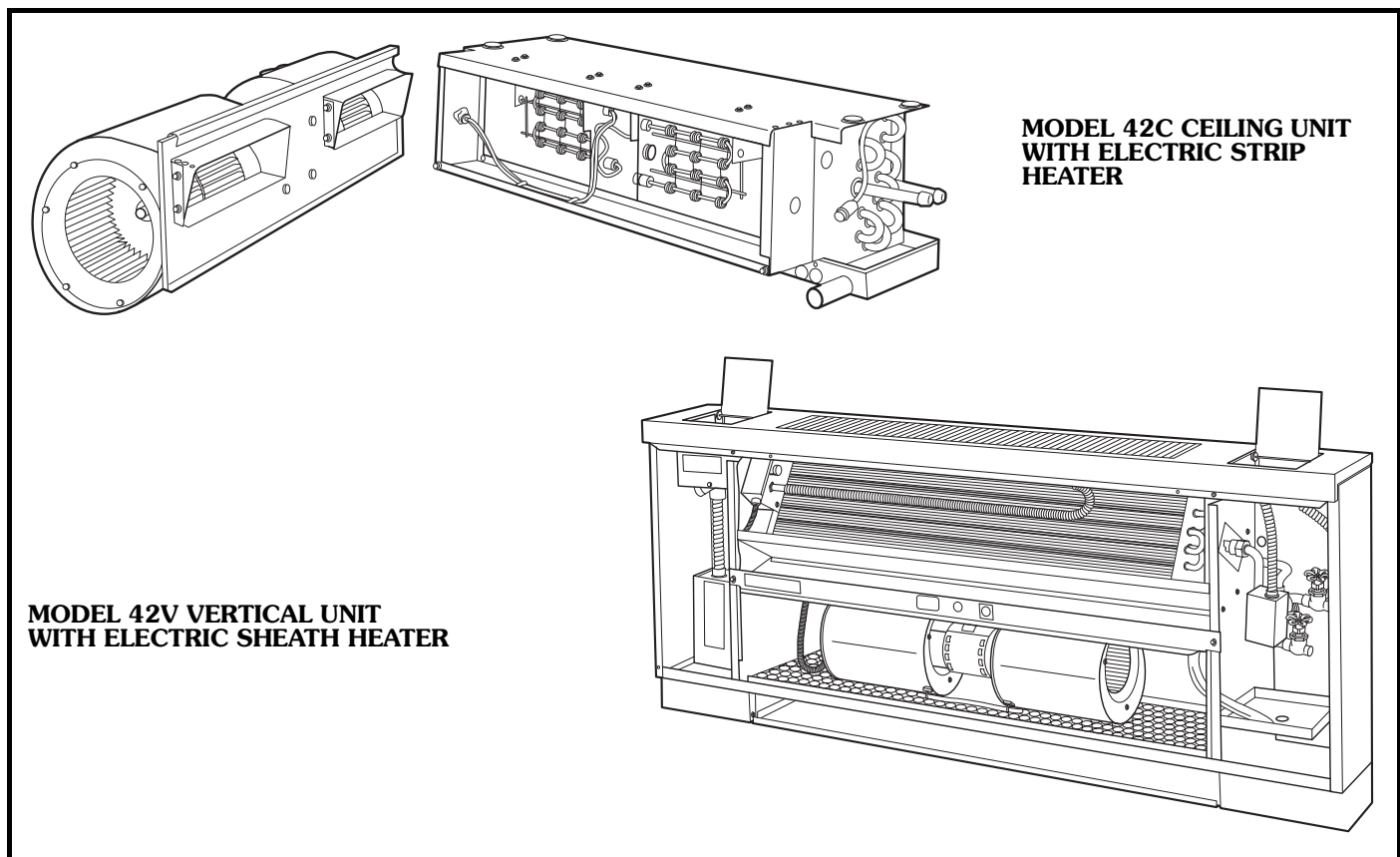

**MODEL 42C CEILING UNIT
WITH ELECTRIC STRIP
HEATER**

**MODEL 42V VERTICAL UNIT
WITH ELECTRIC SHEATH HEATER**



42C SERIES

HEATER VOLTAGE	kW	CAPACITY (Btuh)	UNIT SIZE							
			02	03	04	06	08	10	12	
120	0.5	1,708	*	*						
	1.0	3,415	*	*	*					
	1.5	5,123	*	*						
	2.0	6,830	*	*	*	*	*	*	*	*
	3.0	10,245		*	*	*	*			
208, 240, 277	0.5	1,708	*	*						
	1.0	3,415	*	*	*					
	1.5	5,123	*	*						
	2.0	6,830	*	*	*	*	*	*	*	*
	3.0	10,245		*	*	*	*			
	4.0	13,660				*	*	*	*	*
	5.0	17,075				*	*			
	6.0	20,490				*	*	*	*	*
8.0	27,320						*	*	*	
240,277	10.0	34,150							*	*

42D SERIES

HEATER VOLTAGE	kW	CAPACITY (Btuh)	UNIT SIZE							
			06	08	10	12	14	16	18	20
120	2.0	6,830	*	*	*					
	3.0	10,245	*	*	*					
208, 240, 277	2.0	6,830	*	*	*					
	3.0	10,245	*	*	*					
	4.0	13,660	*	*	*	*	*	*	*	*
	5.0	17,075		*	*	*	*	*	*	*
	6.0	20,490		*	*	*	*	*	*	*
	7.0	23,905			*	*	*	*	*	*
	8.0	27,320				*	*	*	*	*
	9.0	30,735				*	*	*	*	*
	10.0	34,150					*	*	*	*
	12.0	40,980						*	*	*
14.0	47,810								*	

NOTE: All heaters are single-stage and single-phase.

42V SERIES

HEATER VOLTAGE	kW	CAPACITY (Btuh)	UNIT SIZE						
			02	03	04	06	08	10	12
120	0.5	1,708	*	*					
	1.0	3,415	*	*	*	*			
	1.5	5,123		*	*	*			
	2.0	6,830			*	*	*		
	3.0	10,245				*	*	*	*
208, 240, 277	1.0	3,415	*	*	*	*			
	1.5	5,123		*	*	*			
	2.0	6,830			*	*	*		
	3.0	10,245				*	*	*	*
	4.0	13,660					*	*	*
240,277	6.0	20,490						*	*

NOTE: All heaters are single-stage and single-phase. Contact your Carrier representative for heater availability for 220-1-50 units.

42S SERIES

HEATER VOLTAGE	kW	UNIT SIZE					
		03	04	06	08	10	12
120	1.0	*	*	*	*	*	*
	1.5	*	*	*	*	*	*
	2.0	*	*	*	*	*	*
	3.0	*	*	*	*	*	*
208	1.0	*	*	*	*	*	*
	1.5	*	*	*	*	*	*
	2.0	*	*	*	*	*	*
	3.0	*	*	*	*	*	*
	4.0		*	*	*	*	*
	5.0			*	*	*	*
240, 277	6.0				*	*	*
	8.0				*	*	*
	1.0	*	*	*	*	*	*
	1.5	*	*	*	*	*	*
	2.0	*	*	*	*	*	*
	3.0	*	*	*	*	*	*
	4.0		*	*	*	*	*
	5.0			*	*	*	*
	6.0				*	*	*
	8.0				*	*	*
10.0					*	*	

Selection procedure



Refer to the Carrier Electronic Selection Program for information to determine unit sizing for your needs. The following selection procedure applies to all Carrier 42 series units and may be used as a guide to determine unit performance.

FORMULAS

$$TC = TC_b \times C_t \times E_t$$

$$SC = SC_b \times C_s \times E_s$$

Where:

C_s = Sensible Airflow Correction Factor

C_t = Total Airflow Correction Factor

E_s = Sensible Elevation Correction Factor

E_t = Total Elevation Correction Factor

SC = Sensible Capacity

SC_b = Base Sensible Capacity from Base Cooling Capacities by Gpm charts

TC = Total Capacity

TC_b = Base Total Capacity from Base Cooling Capacities by Gpm charts

QUICK SELECTION

EXAMPLE:

To rate the performance at sea level for a 42DCA06 unit with four-row coil at 80 F/67 F EAT, 45 F EWT, and 10 gpm water flow at high speed fan with 0.25 in. wg ESP:

1. Enter the Base Cooling Capacities by Gpm, Standard Capacity Units (Four Row) table on page 77 at 80 F/67 F EAT and 45 F EWT.
2. Locate the appropriate row for unit size 06 and 10 gpm.

Record the tabulated base performance.

$$TC_b = 21.5 \text{ MBtuh}$$

$$SC_b = 15.2 \text{ MBtuh}$$

$$\Delta T = 4.3^\circ \text{ F}$$

3. Select the actual cfm from the Air Delivery table on page 82.

Record actual cfm for 42DCA06 with four-row coil with high speed and 0.25 in. wg ESP.

$$\text{Cfm Actual} = 580$$

4. Divide Cfm Actual by Cfm Nominal to determine Cfm Ratio.

$$\text{Cfm Ratio} = 580/600 = .967$$

5. Select the cfm correction factors, C_t and C_s , from the Airflow Correction Factors table on page 23. (Interpolation may be required.)

$$C_t = 0.98$$

$$C_s = 0.98$$

6. Select the elevation correction factors, E_t and E_s , from the Altitude Correction Factors table on page 23.

$$E_t = 1.00$$

$$E_s = 1.00$$

7. Calculate actual performance.

$$TC = TC_b \times C_t \times E_t$$

$$= 21.5 \times 0.98 \times 1.00$$

$$= 21.1 \text{ MBtuh}$$

$$SC = SC_b \times C_s \times E_s$$

$$= 15.2 \times 0.98 \times 1.00$$

$$= 14.9 \text{ MBtuh}$$

8. Calculate water pressure drop. From the Cv Factor by Coil and Unit Size table on page 86, find the Cv value for unit size 06 with four rows.

$$C_v = 4.00$$

$$\Delta P = [\text{GPM}/(0.658 \times C_v)]^2$$

$$= [10.0/(0.658 \times 4.00)]^2$$

$$= 14.4 \text{ feet of H}_2\text{O}$$

Model number nomenclature



42 CA A 03 A R C Y 5 - - - -

42 – Series Fan-Coil Unit

Model

Vertical Units

- VA – Furred-In
- VB – Cabinet
- VC – Furred-In Lowboy
- VE – Cabinet Lowboy
- VF – Slant-Top Cabinet
- VG – Furred-In Wall Unit

Ceiling Units

- CA – Furred-In
- CE – Furred-In with Plenum
- CF – High Static, Furred-In
- CG – Cabinet
- CK – Telescoping Bottom Panel

Design Series (A or B*)

Unit Size (Airflow, cfm)

- | | |
|----------------------|-----------|
| 01 – 150 (42VG Only) | 06 – 600 |
| 02 – 200 | 08 – 800 |
| 03 – 300 | 10 – 1000 |
| 04 – 400 | 12 – 1200 |

Coil

- A – 3 Row (Standard)
2 Row (VC, VE, VG Standard)
- B – 4 Row High Capacity
3 Row High Capacity (VC, VE Only)
- C – 3/1 Opposite End Connection
2/1 Opposite End Connection (VC, VE Only)
- D – 3/1 Same End Connection
2/1 Same End Connection (VC, VE Only)
- E – 3/2 Opposite End Connection
2/1 Same End Connection (VC, VE Only)
- F – 3/2 Same End Connection
- G – 4/1 Opposite End Connection
- H – 4/1 Same End Connection

Arrangement

42V:

- 5 – Front Return, Top Supply
- 7 – Front Return, Front Supply

42C:

- 5 – Bottom Return, Front Supply
- 6 – Rear Return, Front Supply

Electric Heaters

- Y – None
- A-Z, 1 – 42V
- A-Z, 1-9 – 42C

Motor

- C – 120V Permanent Split Capacitor (PSC) (Standard)
- D – 208/1/60 PSC
- E – 230/1/60 PSC
- F – 277/1/60 PSC
- V – 220/1/50 PSC

Hand

- R – Right
- L – Left

*Model 42CG only.

42C, V Series Units

ARI capacity ratings



The 42C, V series fan coil units are certified in compliance with the Air Conditioning and Refrigeration Institute (ARI) Industry Standard 440-98 for room fan coil units. Approved standard ratings are tabulated below:



42C,V Series Units

ARI APPROVED STANDARD RATINGS*

UNIT	UNIT SIZE	COIL ROWS	NOMINAL CFM	GPM	COOLING CAPACITY		POWER INPUT (WATTS)†
					Total MBtuh	Sensible MBtuh	
42CA,CE,CG,CK	02	3	200	1.2	6.0	4.6	50
	03		300	1.8	9.0	6.9	85
	04		400	2.5	13.3	10.3	165
	06		600	3.6	18.0	14.6	225
	08		800	4.6	22.6	16.9	235
	10		1000	5.5	27.5	21.0	305
	12		1200	6.6	32.8	25.0	435
	02	4	200	1.4	6.9	5.0	50
	03		300	2.1	9.8	6.5	85
	04		400	2.8	13.8	9.8	145
	06		600	4.0	19.6	14.3	220
	08		800	5.1	25.5	18.8	235
	10		1000	6.2	31.0	23.0	300
	12		1200	7.5	37.2	27.7	425
42CF	04	4	400	3.2	16.0	11.6	170
	06		600	4.4	21.8	16.0	205
	08		800	5.3	26.5	19.6	225
	10		1000	7.5	37.2	27.6	355
42VA,VB,VF	02	3	200	1.0	4.8	3.5	50
	03		300	1.5	7.2	5.3	80
	04		400	2.4	11.2	7.9	130
	06		600	3.0	13.9	10.4	180
	08		800	4.0	19.1	13.5	210
	10		1000	4.8	22.0	16.8	240
	12		1200	5.3	26.3	20.0	370
	02	4	200	1.4	6.6	4.1	50
	03		300	2.0	9.9	7.0	80
	04		400	2.7	13.1	8.6	130
	06		600	3.8	18.6	13.6	170
	08		800	4.2	20.6	14.1	195
	10		1000	5.9	29.5	19.6	240
	12		1200	7.8	35.3	26.3	370
42VG	01	2	150	0.6	2.1	1.6	115**
	03		300	1.5	5.2	4.7	225**
42VC,VE	02	2	200	1.2	5.1	3.6	68
	03		300	2.0	8.6	6.7	135
	04		400	2.6	12.3	8.3	150
	06		600	3.6	18.3	13.2	260
	02	3	200	1.3	5.5	3.8	68
	03		300	2.4	10.9	7.1	130
	04		400	3.0	13.4	8.8	145
	06		600	4.1	21.1	14.6	250

LEGEND

GPM — Gallons per minute
MBtuh — Capacity (Btuh in thousands)

*Ratings based on motor at high fan speed, standard air and dry coil operation, 10° F water temperature rise; entering-air temperature 67 F wb; 80 F db; entering water temperature 45 F.

†Motor type permanent split capacitor operating at 115-1-60 voltage.

**Shaded pole motor.

SOUND POWER DATA
42CA,CG,CE,CK SOUND RATINGS — OCTAVE BAND POWER LEVEL RATINGS* (dB)

SIZE	NOMINAL CFM	SPEED	RPM	CENTER FREQUENCY — Hz						
				125	250	500	1000	2000	4000	8000
02	200	High	1130	59	58	59	57	52	49	46
		Medium	1060	54	54	55	51	42	42	41
		Low	940	45	49	51	47	43	37	33
03	300	High	1125	61	59	61	58	54	51	47
		Medium	1025	55	54	54	51	46	42	41
		Low	925	43	48	49	46	42	36	31
04	400	High	1400	62	61	62	59	55	51	46
		Medium	905	54	54	54	50	46	41	26
		Low	725	49	48	47	42	34	—	—
06	600	High	1525	63	62	63	60	56	53	48
		Medium	1100	55	54	54	51	47	41	31
		Low	690	51	50	49	44	36	—	—
08	800	High	1500	66	66	67	64	60	58	53
		Medium	1045	59	56	59	55	47	42	37
		Low	675	51	51	50	46	38	—	—
10	1000	High	1365	73	70	71	68	64	62	58
		Medium	785	62	60	61	57	51	48	46
		Low	700	56	56	57	52	46	40	34
12	1200	High	1540	78	75	76	73	68	67	63
		Medium	1155	68	67	68	64	59	56	54
		Low	740	59	60	60	56	50	43	37

*Testing per ARI Standard 350-86.

42CF SOUND RATINGS — OCTAVE BAND POWER LEVEL RATINGS* (dB)

SIZE	NOMINAL CFM	SPEED	RPM	CENTER FREQUENCY — Hz						
				125	250	500	1000	2000	4000	8000
04	400	High	1085	62	65	65	63	58	54	47
		Medium	980	60	62	62	60	56	51	43
		Low	840	57	59	59	56	51	46	37
06	600	High	1075	62	65	65	63	58	54	47
		Medium	955	60	62	62	60	56	51	43
		Low	740	57	59	59	56	51	46	37
08	800	High	1045	62	65	65	63	58	54	47
		Medium	865	60	62	62	60	56	51	43
		Low	715	57	59	59	56	51	46	37
10	1000	High	1100	62	65	65	63	58	54	47
		Medium	1015	60	62	62	60	56	51	43
		Low	900	57	59	59	56	51	46	37

*Testing per ARI Standard 350-86.

Sound data (cont)



SOUND POWER DATA 42VA,VB,VF SOUND RATINGS — OCTAVE BAND SOUND POWER LEVEL RATINGS* (dB)

42C,V Series Units

SIZE	NOMINAL CFM	SPEED	RPM	CENTER FREQUENCY — Hz						
				125	250	500	1000	2000	4000	8000
02	200	High	1130	63	58	53	46	40	34	25
		Medium	1090	58	57	51	45	39	32	—
		Low	1025	61	57	50	44	37	30	—
03	300	High	1120	65	60	54	48	42	35	26
		Medium	1070	60	59	53	47	41	34	—
		Low	1000	63	59	52	46	39	32	—
04	400	High	1520	66	67	64	58	50	45	39
		Medium	1085	58	60	53	47	40	32	—
		Low	840	52	55	47	40	33	—	—
06	600	High	1625	67	68	65	59	53	48	42
		Medium	1310	61	62	56	52	46	40	—
		Low	825	54	56	48	41	34	—	—
08	800	High	1610	68	68	65	60	55	51	44
		Medium	1300	63	64	59	54	50	45	36
		Low	820	55	56	49	43	37	28	—
10	1000	High	1530	68	69	65	61	54	49	44
		Medium	1095	66	66	60	56	50	45	38
		Low	850	58	58	52	46	38	31	—
12	1200	High	1625	70	71	67	63	56	51	46
		Medium	1310	69	69	63	59	53	48	42
		Low	830	60	61	54	48	41	34	—

*Testing per ARI Standard 350-86.

42VC,VE SOUND RATINGS — OCTAVE BAND SOUND POWER LEVEL RATINGS* (dB)

SIZE	NOMINAL CFM	SPEED	RPM	CENTER FREQUENCY — Hz						
				125	250	500	1000	2000	4000	8000
02	400	High	1325	60	63	60	56	53	50	47
		Medium	890	53	53	51	46	43	38	32
		Low	655	50	48	43	38	33	—	—
03	600	High	1570	64	67	63	60	56	54	50
		Medium	1205	56	58	53	50	47	43	37
		Low	835	49	51	47	41	36	29	—
04	800	High	1520	65	68	64	61	57	55	51
		Medium	1105	57	59	54	51	48	44	38
		Low	765	50	52	48	42	37	30	—
06	1000	High	1575	66	67	63	61	56	53	50
		Medium	1205	58	58	55	53	48	43	37
		Low	835	51	50	47	44	38	30	—

*Testing per ARI Standard 350-86.

Physical data and dimensions

42C, V Series Units

UNIT SIZE 42C	02	03	04	06	08	10	12
NOMINAL AIRFLOW (cfm)	200	300	400	600	800	1000	1200
SHIPPING WEIGHT (lb)*							
42CA	36	39	49	59	64	95	107
42CE	55	60	70	82	95	135	154
42CF	—	—	84	97	110	163	—
42CG	98	118	126	168	176	215	245
42CK	115	120	135	150	155	227	241
COIL WATER WEIGHT (Approx lb per row of coil)							
42CA, CE, CG, CK	0.7	0.8	1.0	1.4	1.7	2.3	2.7
42CF	—	—	1.02	1.42	1.71	2.32	—
COILS							
FPI	10 fins/inch						
Coil Face Area (sq. ft)†	0.8	1.1	1.4	1.9	2.3	3.2	3.7
MOTOR (qty)							
42C Series	1	1	1	1	1	2	2
BLOWER (qty)							
42CA, CE, CG, CK	1	1	2	2	2	4	4
42CF	—	—	2	2	2	4	—
FILTERS							
Nominal Size (in.) (1-in. thick)							
42CA**	10 x 24	10 x 28	10 x 32	10 x 42	10 x 42	10 x 54	10 x 64
42CE††	10 x 18	10 x 22	10 x 28	10 x 33	10 x 40	10 x 54	10 x 64
42CF††***	—	—	12 ³ / ₄ x 28	12 ³ / ₄ x 33	12 ³ / ₄ x 40	12 ³ / ₄ x 54	—
42CG							
Bottom Return	10 x 23 ¹ / ₂	10 x 28	10 x 32 ¹ / ₂	10 x 37	10 x 41	10 x 54 ¹ / ₂	10 x 63
Rear Return	8 x 23 ¹ / ₂	8 x 28	8 x 32 ¹ / ₂	8 x 37	8 x 41	8 x 54 ¹ / ₂	8 x 63
42CK							
Bottom Return	10 x 28	10 x 28	10 x 33	10 x 45	10 x 45	10 x 62	10 x 62
Rear Return	7 x 21	7 x 21	7 x 27	7 x 38	7 x 38	7 x 52	7 x 52
Qty	1	1	1	1	1	1	1
SUPPLY DUCT COLLAR	1-in.						
PIPING CONNECTIONS (Sweat)	1-in.						
Coil Outlet and Inlet	5/8 OD						
Drain Connection	7/8 OD						

*Calculate Operating Weight of unit: Shipping weight + Coil Water Weight x Number of Coil Rows.

†42CF applies to sizes 04 to 10.

**Filter size for return-air grille location.

††Filter size if located in return-air plenum.

***With electric heater and bottom return, the 42CF unit filter width increases from 12³/₄ to 16³/₄.

UNIT SIZE 42V	01	02	03	04	06	08	10	12
NOMINAL AIRFLOW (cfm)	150	200	300	400	600	800	1000	1200
SHIPPING WEIGHT (lb)*								
42VA	—	65	80	90	112	115	140	170
42VB	—	89	95	116	134	137	169	192
42VC	—	50	60	72	110	—	—	—
42VE	—	72	100	108	154	—	—	—
42VF	—	92	98	122	141	144	178	205
42VG	40	—	74	—	—	—	—	—
COIL WATER WEIGHT (Approx lb per row of coil)								
42VA, VB, VC†, VF	—	0.7	0.8	1.0	1.4	1.7	2.3	2.7
42VE	—	0.9	1.2	1.6	2.3	—	—	—
42VG	0.4	—	1.0	—	—	—	—	—
COILS								
FPI	12 fins/inch							
Coil Face Area (ft ²)	0.8	0.8	1.1	1.4	1.9	2.3	3.2	3.7
MOTOR (qty)								
42VA, VB, VF	—	1	1	1	1	1	2	2
42VC, VE	—	1	1	1	2	—	—	—
42VG	1	—	2	—	—	—	—	—
BLOWER (qty)								
42VA, VB, VF	—	1	1	2	2	2	4	4
42VC, VE	—	2	2	2	4	—	—	—
42VG	1	—	2	—	—	—	—	—
FILTERS								
Nominal Size (in.) (1-in. thick)								
42VA, VB, VF	—	7 ³ / ₄ x 21 ³ / ₄	7 ³ / ₄ x 25 ³ / ₄	7 ³ / ₄ x 31 ³ / ₄	7 ³ / ₄ x 41 ³ / ₄	7 ³ / ₄ x 43 ³ / ₄	7 ³ / ₄ x 57 ³ / ₄	7 ³ / ₄ x 65 ³ / ₄
42VC, VE	—	6 ³ / ₄ x 21 ³ / ₄	6 ³ / ₄ x 26 ³ / ₄	6 ³ / ₄ x 34 ³ / ₄	6 ³ / ₄ x 48 ³ / ₄	—	—	—
42VG	10 x 14 ¹ / ₂	—	10 x 28	—	—	—	—	—
Qty	—	1	1	1	1	1	1	1
SUPPLY DUCT COLLAR	1-in.							
PIPING CONNECTIONS (Sweat)	1-in.							
Coil Outlet and Inlet	5/8 OD							
Drain Connection	3/4 MPT							

*Calculate Operating Weight of unit: Shipping weight + Coil Water Weight x Number of Coil Rows.

†Available in sizes 02-06.

Physical data and dimensions (cont)



42C,V Series Units

42CA FURRED-IN HORIZONTAL UNIT

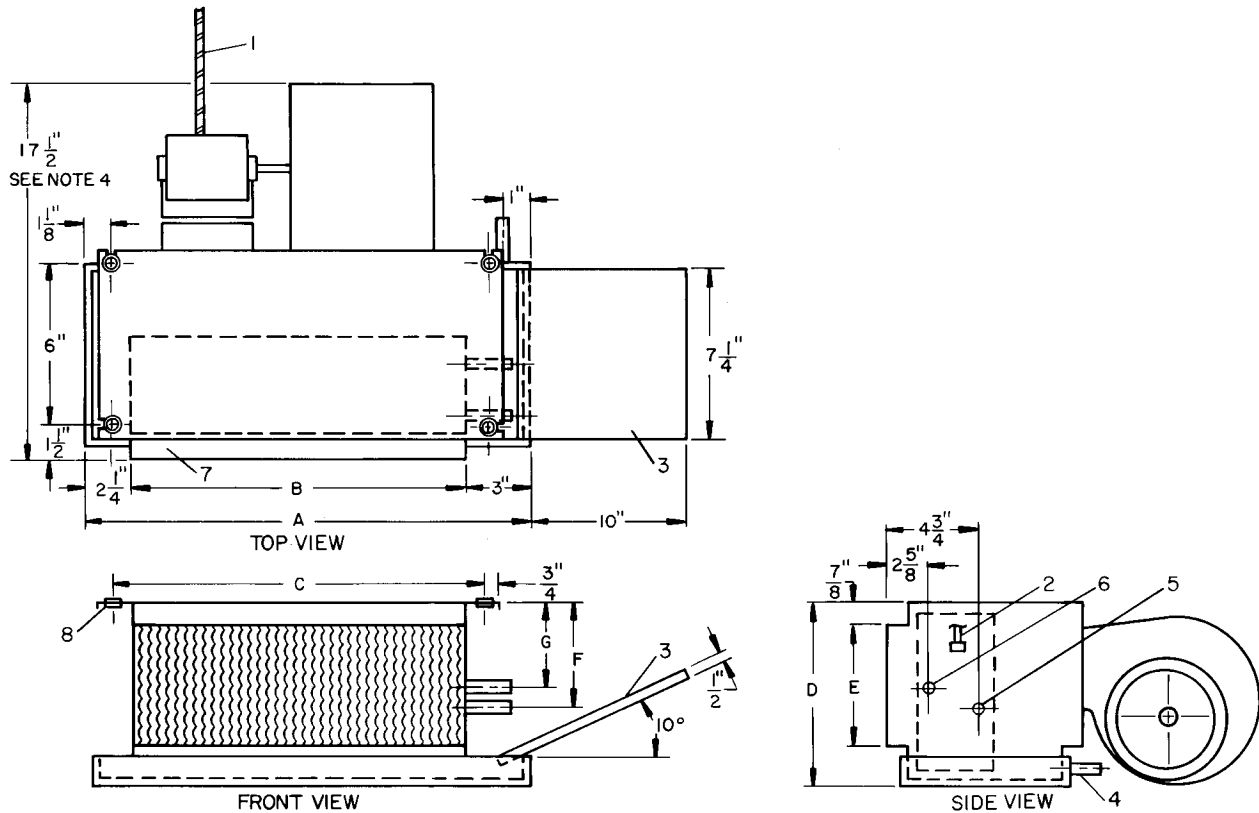

LEGEND

- 1 — Flexible Metal Conduit
- 2 — Air Vent, 1/8-in. MPT
- 3 — Drip Lip (optional)
- 4 — Drain Conn, 7/8-in. OD
- 5 — Return Conn, 5/8-in. OD
- 6 — Supply Conn, 5/8-in. OD
- 7 — Supply Duct Collar, 1-in.
- 8 — Hanger Slots (4), Rubber Grommet has 3/8-in. Diameter Hole

NOTES:

1. Right hand unit shown; left hand unit opposite. Coil connection locations are $\pm 5/8$ -in.
2. Unit sizes 02 and 03 have one motor, one blower; sizes 04 through 08 have one motor, 2 blowers; sizes 10 and 12 have 2 motors, 4 blowers.
3. Standard 3-row coil shown.
4. Overall unit dimension increases by 4 in. with optional electric heat.
5. Not shown: 3-speed fan switch; wall plate, closed cell foam on main drain pan.
6. Units have galvanized finish.
7. See 42CA-203-1 for optional coil connections.

UNIT SIZE	NOM AIRFLOW (Cfm)	DIMENSIONS (in.)							FACE AREA (sq ft)
		A	B	C	D	E	F	G	
02	200	21 1/4	16	18 1/4	8 3/4	6 1/4	4 1/4	4 1/4	0.83
03	300	25 1/4	20	22 1/4	8 3/4	6 1/4	4 1/4	4 1/4	1.08
04	400	31 1/4	26	28 1/4	8 3/4	6 1/4	4 1/4	4 1/4	1.35
06	600	36 1/4	31	33 1/4	10	7 1/2	4 7/8	3 5/8	1.88
08	800	43 1/4	38	40 1/4	10	7 1/2	4 7/8	3 5/8	2.31
10	1000	57 1/4	52	54 1/4	10	7 1/2	3 5/8	4 7/8	3.16
12	1200	65 1/4	60	62 1/4	10	7 1/2	3 5/8	4 7/8	3.65

42CE FURRED-IN HORIZONTAL UNIT WITH PLENUM

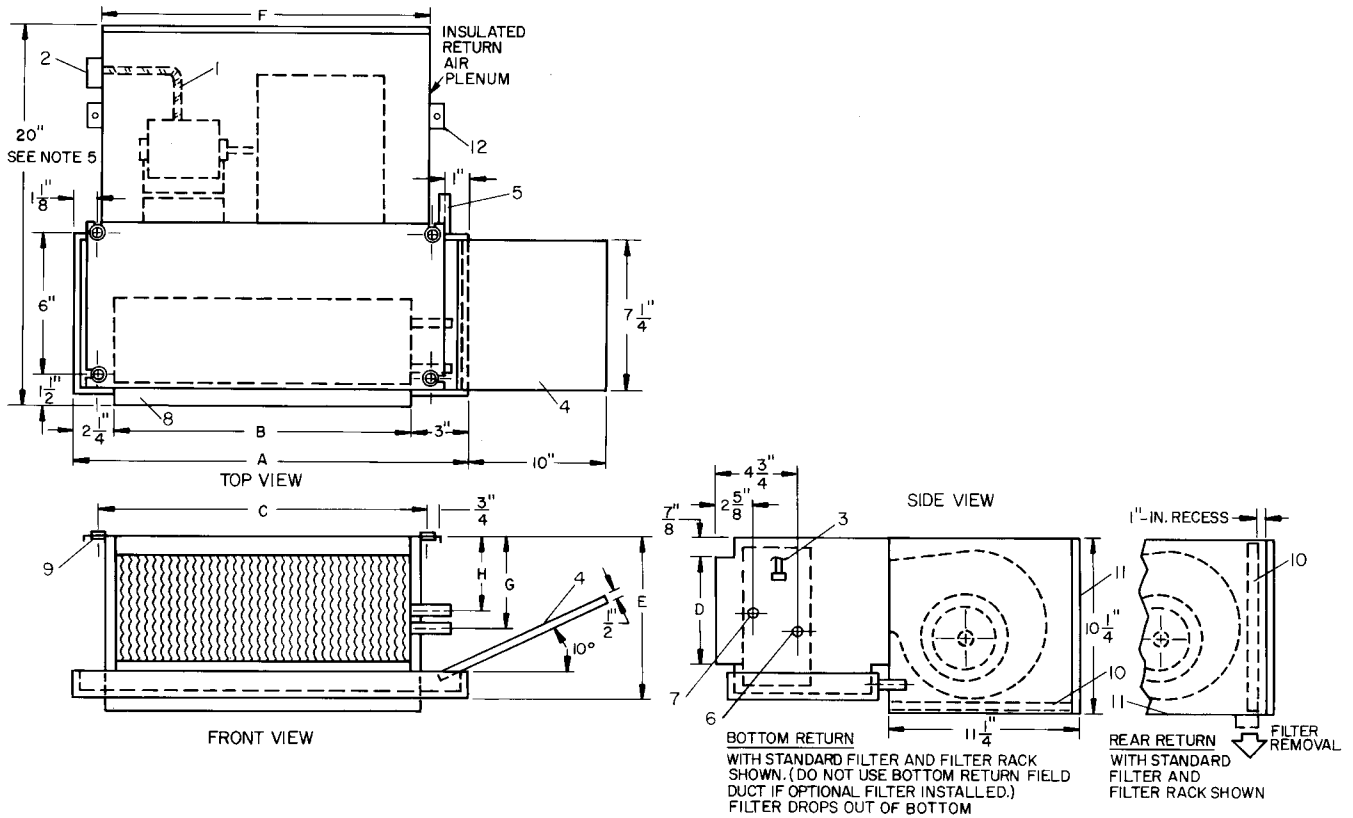

LEGEND

- 1 — Flexible Metal Conduit
- 2 — Junction Box, 4 in. x 4 in.
- 3 — Air Vent, 1/8-in. MPT
- 4 — Drip Lip (optional, shipped loose)
- 5 — Drain Conn, 7/8-in. OD
- 6 — Return Conn, 5/8-in. OD
- 7 — Supply Conn, 5/8-in. OD
- 8 — Supply Duct Collar, 1-in.
- 9 — Hanger Slots (4), Rubber Grommet has 3/8-in. Diameter Hole
- 10 — Filter
- 11 — Access Panel
- 12 — Mounting Bracket

NOTES:

1. Right hand unit with standard 3-row coil shown; left hand unit opposite. Coil connection locations are ±5/8-in.
2. Unit sizes 02 and 03 have one motor, one blower; sizes 04 through 08 have one motor, 2 blowers; sizes 10 and 12 have 2 motors, 4 blowers.
3. Standard 3-row coil shown.
4. Unit available with bottom or rear return air.
5. Dimension increases by 4 in. with optional electric heat.
6. Not shown: 3-speed fan switch; wall plate, 1/2-in. fiberglass insulation on inside of plenum, closed cell foam on main drain pan.
7. Units have galvanized finish.
8. See 42CA-203-1 for optional coil connections.

UNIT SIZE	NOM AIRFLOW (Cfm)	DIMENSIONS (in.)								FACE AREA (sq ft)
		A	B	C	D	E	F	G	H	
02	200	21 1/4	16	18 1/4	6 1/4	8 3/4	18 1/4	4 1/4	4 1/4	0.83
03	300	25 1/4	20	22 1/4	6 1/4	8 3/4	22 1/4	4 1/4	4 1/4	1.08
04	400	31 1/4	26	28 1/4	6 1/4	8 3/4	28 1/4	4 1/4	4 1/4	1.35
06	600	36 1/4	31	33 1/4	7 1/2	10	33 1/4	4 7/8	3 5/8	1.88
08	800	43 1/4	38	40 1/4	7 1/2	10	40 1/4	4 7/8	3 5/8	2.31
10	1000	57 1/4	52	54 1/4	7 1/2	10	54 1/4	3 5/8	4 7/8	3.16
12	1200	65 1/4	60	62 1/4	7 1/2	10	62 1/4	3 5/8	4 7/8	3.65

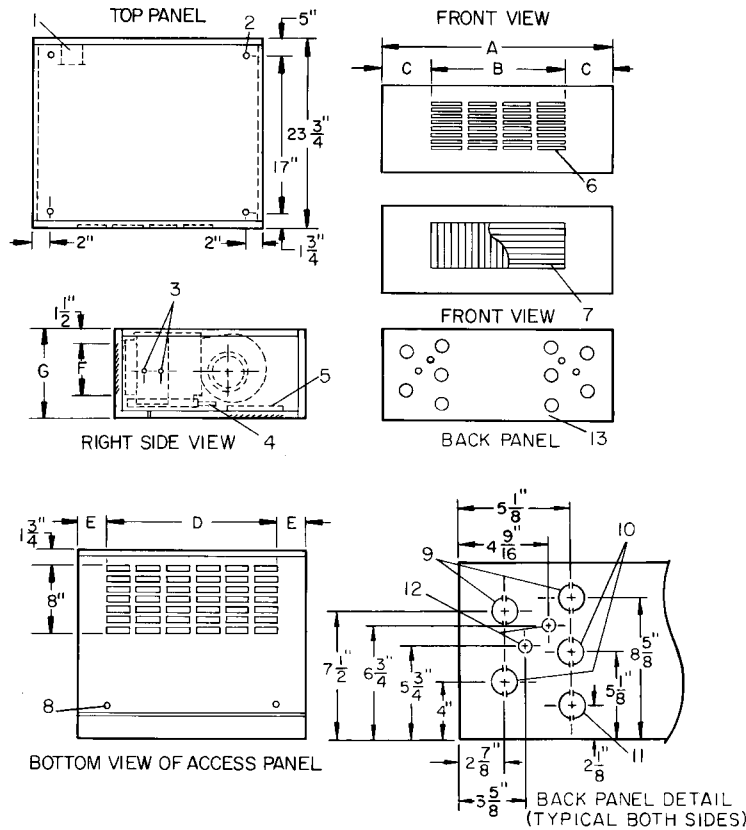
42CG HORIZONTAL CABINET UNIT

LEGEND

- 1 — Junction Box, 4 in. x 4 in.
- 2 — Mounting Holes (4), Rubber Grommets have 3/8-in. Diameter Hole
- 3 — Supply, Return Connections, 5/8-in. OD
- 4 — Drain Connection, 7/8-in. OD
- 5 — Filter
- 6 — Supply Grille, Stamped, Standard
- 7 — Supply Grille, Single or Double Deflection, Optional (consult factory for dimensions)
- 8 — Camloc (2)
- 9 — Return KO, 1-in. Diameter
- 10 — Supply KO, 1 1/2-in. Diameter
- 11 — Drain KO, 1 1/2-in. Diameter
- 12 — Electrical KO, 7/8-in. Diameter
- 13 — Optional Stamped Rear Return Grille

NOTES:

- 1. Right hand unit shown; left hand unit opposite. Coil connection locations are $\pm 5/8$ -in.
- 2. Unit sizes 02 and 03 have one motor, one blower; sizes 04 through 08 have one motor, 2 blowers; sizes 10 and 12 have 2 motors, 4 blowers.
- 3. Cabinet has an Arctic White baked finish.
- 4. Refer to 42CA dimensions for coil stub-out locations.
- 5. Not shown: optional drip lip, 3-speed fan switch; wall plate, 1/2-in. fiberglass insulation on inside of casing, closed cell foam on main drain pan.
- 6. See 42CA-203-1 for optional coil connections.

UNIT SIZE	NOM AIRFLOW (Cfm)	DIMENSIONS (in.)							FACE AREA (sq ft)
		A	B	C	D	E	F	G	
02	200	38	17 1/8	10 7/16	21 1/2	3 7/8	5 3/4	11	0.83
03	300	42	21 1/2	10 1/4	25 7/8	3 11/16	5 3/4	11	1.08
04	400	48	25 7/8	11 1/16	30 1/4	4 1/2	5 3/4	11	1.35
06	600	53	34 5/8	9 3/16	34 5/8	4 13/16	6 3/4	12	1.88
08	800	60	39	10 1/2	39	6 1/8	6 3/4	12	2.31
10	1000	74	52 1/8	10 15/16	52 1/8	6 9/16	6 3/4	12	3.16
12	1200	82	60 7/8	10 9/16	60 7/8	6 3/16	6 3/4	12	3.65

Physical data and dimensions (cont)



42C,V Series Units

42CK HORIZONTAL CABINET UNIT WITH TELESCOPING ACCESS PANEL

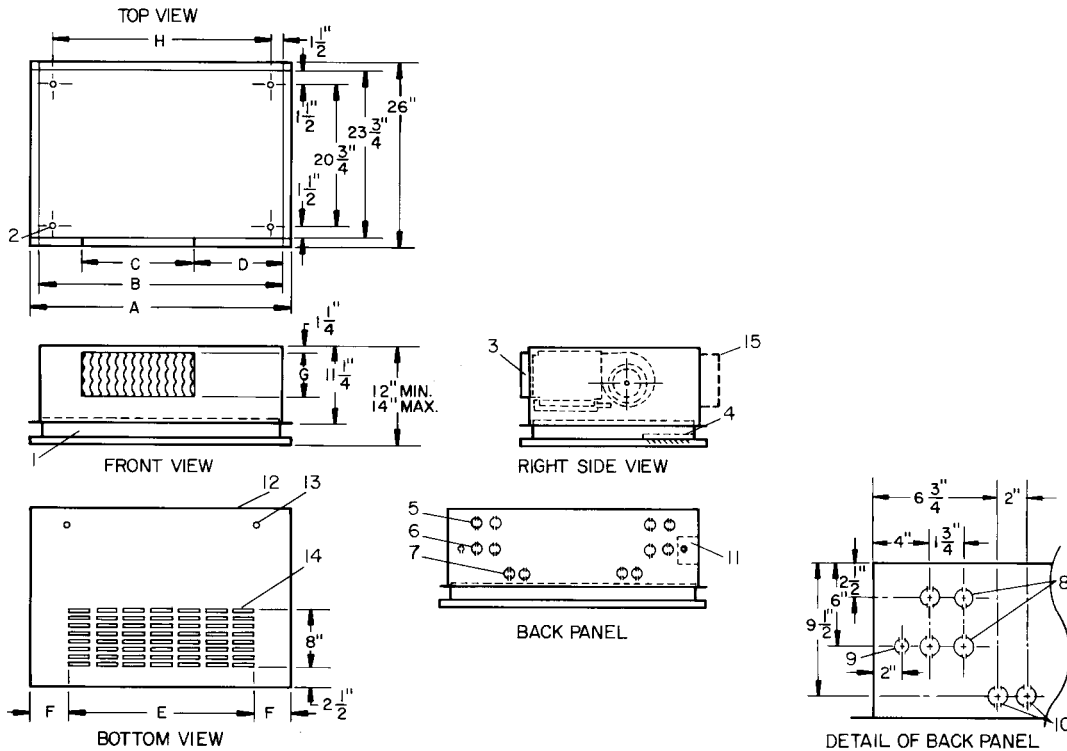

LEGEND

- 1 — Duct Collar, Telescoping
- 2 — Mounting Holes (4), Rubber Grommets have $\frac{3}{8}$ -in. Diameter Hole
- 3 — Supply Duct Collar
- 4 — Filter
- 5 — Return Connection, $\frac{5}{8}$ -in. OD.
- 6 — Supply Connection, $\frac{5}{8}$ -in. OD.
- 7 — Drain, $\frac{7}{8}$ -in. OD.
- 8 — Piping KO, $1\frac{1}{2}$ -in. Diameter
- 9 — Electrical KO, $\frac{7}{8}$ -in. Diameter
- 10 — Drain KO, $1\frac{1}{2}$ -in. Diameter
- 11 — Junction Box, 4 in. x 4 in.
- 12 — Hinged Bottom Access Panel
- 13 — Camloc (2)
- 14 — Stamped Bottom Return Air Grille
- 15 — Optional Rear Return. Consult factory for collar dimensions.

NOTES:

1. Right hand unit shown; left hand unit opposite. Coil connection locations are $\pm\frac{9}{8}$ -in.
2. Unit sizes 02 and 03 have one motor, one blower; sizes 04 through 08 have one motor, 2 blowers; sizes 10 and 12 have 2 motors, 4 blowers.
3. Bottom access panel has an Arctic White baked finish.
4. Refer to 42CA dimensions for coil stub-out locations.
5. Not shown: optional drip lip, 3-speed fan switch; wall plate, $\frac{1}{2}$ -in. fiberglass insulation on inside of casing, closed cell foam on main drain pan.
6. See 42CA-203-1 for optional coil connections.

UNIT SIZE	NOM AIRFLOW (Cfm)	DIMENSIONS (in.)								FACE AREA (sq ft)
		A	B	C	D	E	F	G	H	
02	200	37	35	16	$12\frac{3}{4}$	$25\frac{7}{8}$	$4\frac{9}{16}$	6	32	0.83
03	300	37	35	20	$8\frac{3}{4}$	$25\frac{7}{8}$	$4\frac{9}{16}$	6	32	1.08
04	400	43	41	26	$8\frac{3}{4}$	$30\frac{1}{4}$	$5\frac{3}{8}$	6	38	1.35
06	600	55	53	31	$15\frac{3}{4}$	$43\frac{3}{8}$	$4\frac{13}{16}$	7	50	1.88
08	800	55	53	38	$8\frac{3}{4}$	$43\frac{3}{8}$	$4\frac{13}{16}$	7	50	2.31
10	1000	77	75	52	$16\frac{3}{4}$	$60\frac{7}{8}$	$7\frac{1}{16}$	7	72	3.16
12	1200	77	75	60	$8\frac{3}{4}$	$60\frac{7}{8}$	$7\frac{1}{16}$	7	72	3.65

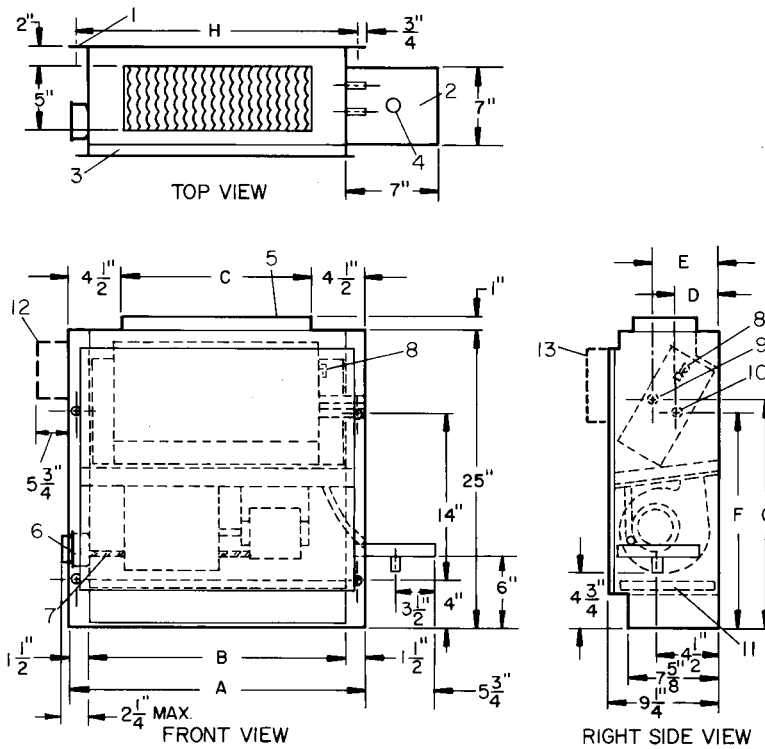
42VA FURRED-IN VERTICAL UNIT

LEGEND

- 1 — Wall Mounting Holes (4), 3/4-in. Diameter
- 2 — Drain Pan, Auxiliary, Shipped Loose
- 3 — Front Access Panel
- 4 — Drain, 3/4-in. MPT
- 5 — Discharge Opening
- 6 — Junction Box, 4 in. x 4 in.
- 7 — Flexible Conduit
- 8 — Air Vent, 1/8-in. MPT
- 9 — Supply Conn, 5/8-in. OD
- 10 — Return Conn, 5/8-in. OD
- 11 — Filter
- 12 — Unit-Mounted Control Box (Optional)
- 13 — Optional Front Discharge. Consult factory for dimensions. (Includes collar only if no wall panels ordered.)

NOTES:

1. Right hand unit shown; left hand unit opposite. Coil connection locations are $\pm 5/8$ -in.
2. Unit sizes 02 and 03 have one motor, one blower; sizes 04 through 08 have one motor, 2 blowers; sizes 10 and 12 have 2 motors, 4 blowers.
3. Standard 3-row coil shown.
4. Optional unit-mounted switch box and controls, when specified, are installed on opposite side from cooling connections.
5. Not shown: 3-speed fan switch; wall plate, 1/2-in. fiberglass insulation on inside of casing, closed cell foam on main drain pan.
6. Units have galvanized finish.
7. See 42VA-203-1 for optional coil connections.

UNIT SIZE	NOM AIRFLOW (Cfm)	DIMENSIONS (in.)								FACE AREA (sq ft)
		A	B	C	D	E	F	G	H	
02	200	25	22	16	4	5 ¹⁵ / ₁₆	17 ¹ / ₁₆	18 ¹ / ₈	23 ¹ / ₂	0.83
03	300	29	26	20	4	5 ¹⁵ / ₁₆	17 ¹ / ₁₆	18 ¹ / ₈	27 ¹ / ₂	1.08
04	400	35	32	26	4	5 ⁵ / ₁₆	17 ¹ / ₁₆	18 ¹ / ₈	33 ¹ / ₂	1.35
06	600	45	42	36	3 ¹¹ / ₁₆	5 ⁵ / ₈	17 ⁵ / ₈	18 ¹¹ / ₁₆	43 ¹ / ₂	1.88
08	800	47	45	38	3 ¹¹ / ₁₆	5	17 ⁵ / ₈	19 ³ / ₄	46 ¹ / ₂	2.31
10	1000	61	58	52	3 ¹ / ₁₆	5 ⁵ / ₈	18 ³ / ₄	18 ¹¹ / ₁₆	59 ¹ / ₂	3.16
12	1200	69	66	60	3 ¹ / ₁₆	5 ⁵ / ₈	18 ³ / ₄	18 ¹¹ / ₁₆	67 ¹ / ₂	3.65

Physical data and dimensions (cont)



42C,V Series Units

42VB VERTICAL CABINET UNIT

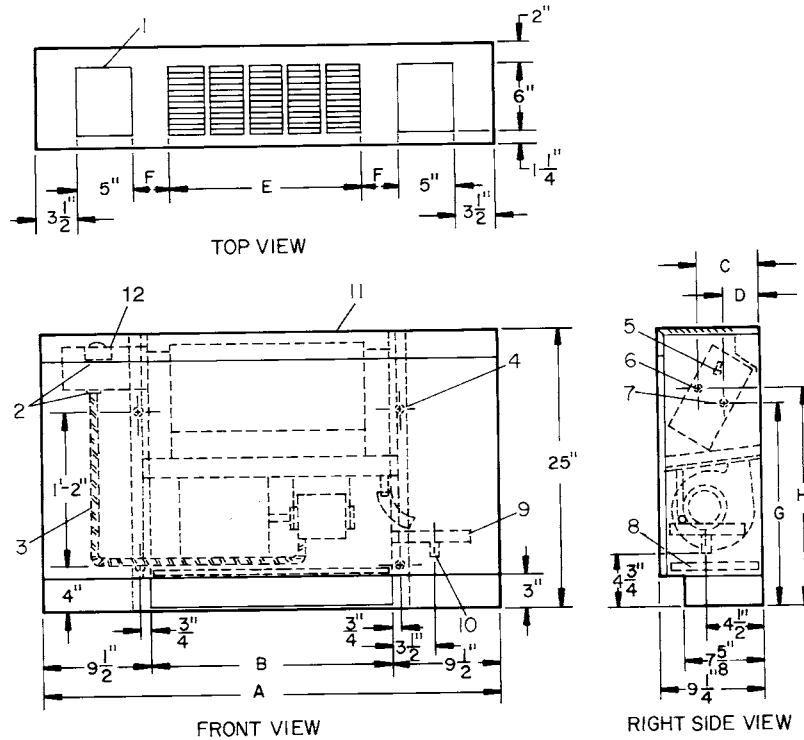

LEGEND

- 1 — Access Door, Fan Switch
- 2 — Electrical KO
- 3 — Flexible Conduit
- 4 — Wall Mounting Holes (4), 3/4-in. Diameter
- 5 — Air Vent, 1/8-in. MPT
- 6 — Supply Conn, 5/8-in. OD
- 7 — Return Conn, 5/8-in. OD
- 8 — Filter
- 9 — Drain Pan, Auxiliary, Shipped Loose
- 10 — Drain, 3/4-in. MPT
- 11 — Optional Front Discharge
- 12 — Fan Switch, 3-speed

NOTES:

1. Right hand unit shown; left hand unit opposite. Coil connection locations are $\pm 5/8$ -in.
2. Unit sizes 02 and 03 have one motor, one blower; sizes 04 through 08 have one motor, 2 blowers; sizes 10 and 12 have 2 motors, 4 blowers.
3. Standard 3-row coil shown.
4. Cabinet has an Arctic White baked finish.
5. Stamped supply grille standard. Optional single or double deflection grilles available.
6. Not shown: 1/2-in. fiberglass insulation on inside of casing, closed cell foam on main drain pan.
7. See 42VA-203-1 for optional coil connections.

UNIT SIZE	NOM AIRFLOW (Cfm)	DIMENSIONS (in.)								FACE AREA (sq ft)
		A	B	C	D	E	F	G	H	
02	200	41	22	5 ⁵ / ₁₆	4	17 ¹ / ₈	3 ⁷ / ₁₆	17 ¹ / ₁₆	18 ¹ / ₈	0.83
03	300	45	26	5 ⁵ / ₁₆	4	21 ¹ / ₂	3 ¹ / ₄	17 ¹ / ₁₆	18 ¹ / ₈	1.08
04	400	51	32	5 ⁵ / ₁₆	4	25 ⁷ / ₈	4 ¹ / ₁₆	17 ¹ / ₁₆	18 ¹ / ₈	1.35
06	600	61	42	5 ⁵ / ₈	3 ¹¹ / ₁₆	39	2 ¹ / ₂	17 ⁵ / ₈	18 ¹¹ / ₁₆	1.88
08	800	63	44	5	3 ¹¹ / ₁₆	39	3 ¹ / ₂	17 ⁵ / ₈	19 ³ / ₄	2.31
10	1000	77	58	5 ⁵ / ₈	3 ¹ / ₁₆	52 ¹ / ₈	3 ¹⁵ / ₁₆	18 ³ / ₄	18 ¹¹ / ₁₆	3.16
12	1200	85	66	5 ⁵ / ₈	3 ¹ / ₁₆	60 ⁷ / ₈	3 ⁵ / ₁₆	18 ³ / ₄	18 ¹¹ / ₁₆	3.65

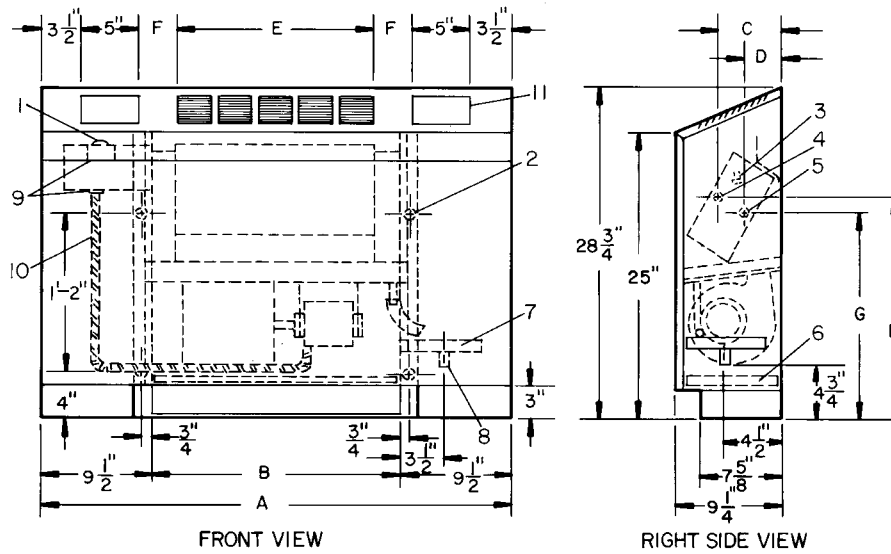
42VF VERTICAL CABINET UNIT WITH SLANT TOP

LEGEND

- 1 — Fan Switch, 3 speed
- 2 — Wall Mounting Holes $\frac{3}{4}$ -in. Diameter
- 3 — Air Vent, $\frac{1}{8}$ -in. MPT
- 4 — Supply Conn, $\frac{5}{8}$ -in. OD
- 5 — Return Conn, $\frac{5}{8}$ -in. OD
- 6 — Filter
- 7 — Drain Pan, Auxiliary, Shipped Loose
- 8 — Drain, $\frac{3}{4}$ -in. MPT
- 9 — Electrical KO
- 10 — Flexible Conduit
- 11 — Access Doors

NOTES:

1. Right hand unit shown; left hand unit opposite. Coil connection locations are $\pm \frac{5}{8}$ -in.
2. Unit sizes 02 and 03 have one motor, one blower; sizes 04 through 08 have one motor, 2 blowers; sizes 10 and 12 have 2 motors, 4 blowers.
3. Standard 3-row coil shown.
4. Cabinet has an Arctic White baked finish.
5. Not shown: $\frac{1}{2}$ -in. fiberglass insulation on inside of casing, closed cell foam on main drain pan.
6. See 42VA-203-1 for optional coil connections.

UNIT SIZE	NOM AIRFLOW (Cfm)	DIMENSIONS (in.)								FACE AREA (sq ft)
		A	B	C	D	E	F	G	H	
02	200	41	22	$5\frac{5}{16}$	4	$17\frac{1}{8}$	$\frac{37}{16}$	$17\frac{1}{16}$	$18\frac{1}{8}$	0.83
03	300	45	26	$5\frac{9}{16}$	4	$21\frac{1}{2}$	$\frac{31}{4}$	$17\frac{1}{16}$	$18\frac{1}{8}$	1.08
04	400	51	32	$5\frac{9}{16}$	4	$25\frac{7}{8}$	$\frac{41}{16}$	$17\frac{1}{16}$	$18\frac{1}{8}$	1.35
06	600	61	42	$5\frac{9}{8}$	$3\frac{11}{16}$	39	$2\frac{1}{2}$	$17\frac{5}{8}$	$18\frac{11}{16}$	1.88
08	800	63	44	5	$3\frac{11}{16}$	39	$\frac{31}{2}$	$17\frac{5}{8}$	$19\frac{3}{4}$	2.31
10	1000	77	58	$5\frac{5}{8}$	$3\frac{1}{16}$	$52\frac{1}{8}$	$\frac{315}{16}$	$18\frac{3}{4}$	$18\frac{11}{16}$	3.16
12	1200	85	66	$5\frac{5}{8}$	$3\frac{1}{16}$	$60\frac{1}{8}$	$\frac{35}{16}$	$18\frac{3}{4}$	$18\frac{11}{16}$	3.65

Physical data and dimensions (cont)



42C,V Series Units

42VC FURRED-IN LOBOY UNIT

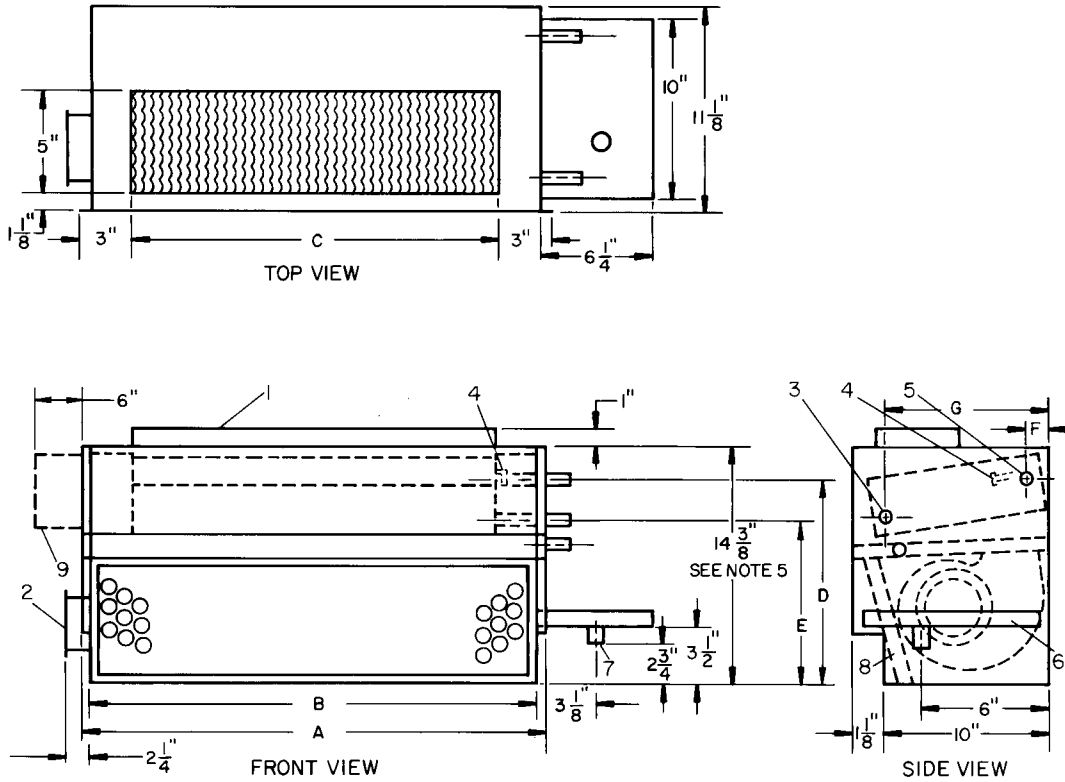

LEGEND

- 1 — Discharge Opening
- 2 — Junction Box, 4 in. x 4 in.
- 3 — Return Conn, 5/8-in. OD
- 4 — Air Vent, 1/8-in. MPT
- 5 — Supply Conn, 5/8-in. OD
- 6 — Drain Pan, Auxiliary, Shipped Loose
- 7 — Drain, 3/4-in. MPT
- 8 — Filter
- 9 — Unit-Mounted Control Box (Optional)

NOTES:

1. Right hand unit shown; left hand unit opposite. Coil connection locations are $\pm 5/8$ -in.
2. Unit sizes 02 through 04 have one motor, 2 blowers; size 06 has 2 motors, 4 blowers.
3. Standard 2-row coil shown.
4. Optional unit-mounted switch box and controls, when specified, are installed on opposite side from cooling connections.
5. Height increases by 2 in. with electric heat.
6. Not shown: 3-speed fan switch, 1/2-in. fiberglass insulation on inside of casing, closed cell foam on main drain pan.
7. Units have galvanized finish.
8. See 42VC-203-1 for optional coil connections.

UNIT SIZE	NOM AIRFLOW (Cfm)	DIMENSIONS (in.)							FACE AREA (sq ft)
		A	B	C	D	E	F	G	
02	200	23	22	17	11 1/4	10 7/16	1	10 3/8	1.18
03	300	28	27	22	11 1/4	10 7/16	1	10 3/8	1.53
04	400	36	35	30	11 1/4	10 7/16	1	10 3/8	2.08
06	600	50	49	44	11 3/4	10	1 1/4	10	3.06

42VE CABINET LOBOY UNIT

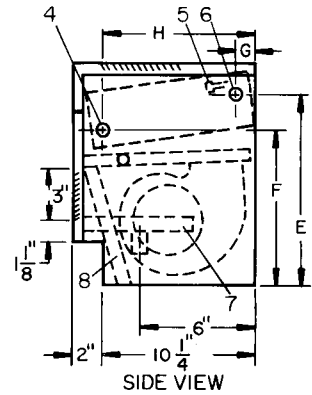
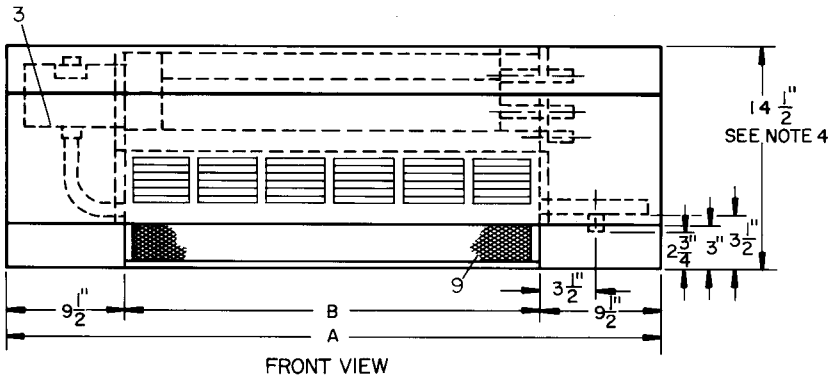
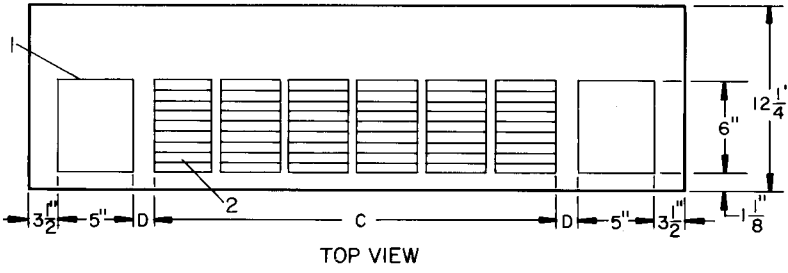

LEGEND

- 1 — Fan Switch, 3-Speed, behind Access Door
- 2 — Stamped Supply Grille
- 3 — Electrical KO
- 4 — Return Conn, 5/8-in. OD
- 5 — Air Vent, 1/8-in. MPT
- 6 — Supply Conn, 5/8-in. OD
- 7 — Drain Pan, Auxiliary, with 3/4-in. MPT Drain Connection
- 8 — Filter
- 9 — Return Air Grille

NOTES:

- 1. Right hand unit shown; left hand unit opposite. Coil connection locations are $\pm 5/8$ -in.
- 2. Unit sizes 02 through 04 have one motor, 2 blowers; size 06 has 2 motors, 4 blowers.
- 3. Cabinet has an Arctic White baked finish.
- 4. Height increases by 2 in. with electric heat.
- 5. Standard 2-row coil shown.
- 6. Not shown: 1/2-in. fiberglass insulation on inside of casing, closed cell foam on main drain pan.
- 8. See 42VC-203-1 for optional coil connections.

UNIT SIZE	NOM AIRFLOW (Cfm)	DIMENSIONS (in.)								FACE AREA (sq ft)
		A	B	C	D	E	F	G	H	
02	200	41	22	17 ¹ / ₈	3 ⁷ / ₁₆	11 ¹ / ₄	10 ⁷ / ₁₆	1	10 ³ / ₈	1.18
03	300	46	27	21 ¹ / ₂	3 ³ / ₄	11 ¹ / ₄	10 ⁷ / ₁₆	1	10 ³ / ₈	1.53
04	400	54	35	30 ¹ / ₄	3 ³ / ₈	11 ¹ / ₄	10 ⁷ / ₁₆	1	10 ³ / ₈	2.08
06	600	68	49	43 ³ / ₈	3 ¹³ / ₁₆	11 ³ / ₄	10	1 ¹ / ₄	10 ³ / ₈	3.06

Physical data and dimensions (cont)



42C,V Series Units

42VG FURRED-IN WALL UNIT

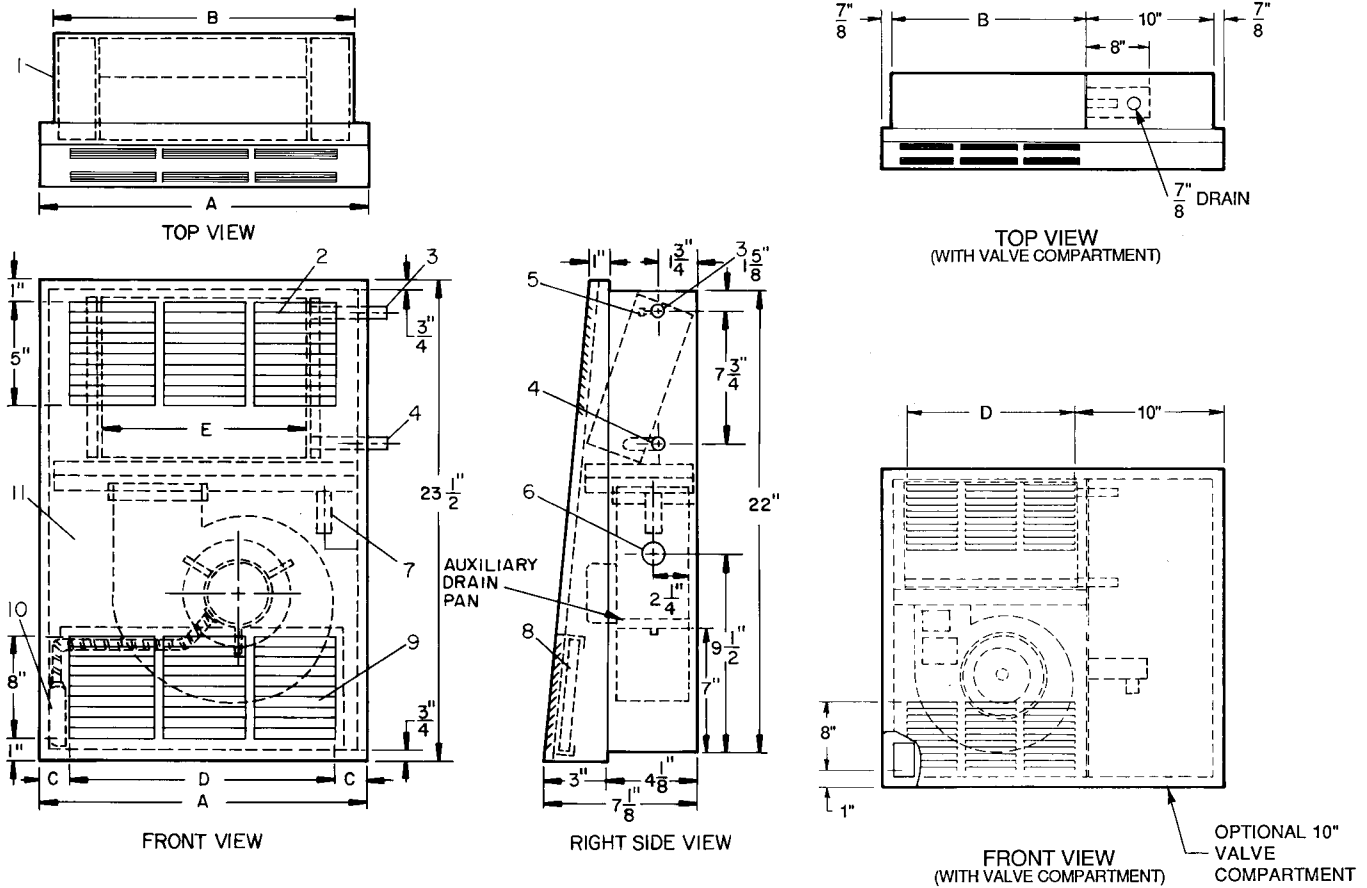

LEGEND

- 1 — Electrical KO, 7/8-in. Diameter
- 2 — Stamped Supply Grille
- 3 — Return Conn, 5/8-in. OD
- 4 — Supply Conn, 5/8-in. OD
- 5 — Air Vent, 1/8-in. MPT
- 6 — Opening for Drain Conn, 1-in. Diameter
- 7 — Drain Conn, 7/8-in. OD
- 8 — Filter
- 9 — Return Air Grille, Stamped
- 10 — Junction Box
- 11 — Front Panel

NOTES:

1. Right hand unit shown; left hand unit opposite. Coil connection locations are $\pm 5/8$ -in.
2. Front panel has an Arctic White baked finish.
3. Standard 2-row coil shown.
4. Unit size 01 has one motor, one blower; size 03 has 2 motors, 2 blowers.
5. Unit has 1/2-in. flanges for mounting to wall surface.
6. Front panel hooks at top of unit, swing down and snap in at bottom against a spring clip.
7. Not shown: 3-speed fan switch, wall plate, 1/2-in. fiberglass insulation on inside of casing, closed cell foam on main drain pan.

UNIT SIZE	NOM AIRFLOW (Cfm)	DIMENSIONS (in.)				
		A	B	C	D	E
01	150	25 3/4	14	1 1/2	12 3/4	10
03	300	39 3/4	28	1 15/16	25 7/8	24

Accessory dimensions



OUTSIDE AIR OPENING/DAMPER

UNIT SIZE	NOMINAL AIRFLOW (CFM)	DIM. A (in.)
02	200	8
03	300	10
04	400	12
06	600	14
08	800	18
10	1000	27
12	1200	27

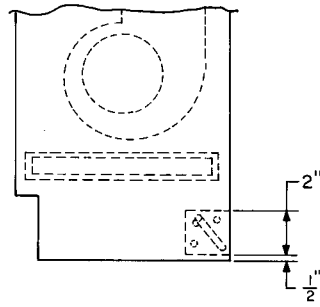

SIDE VIEW

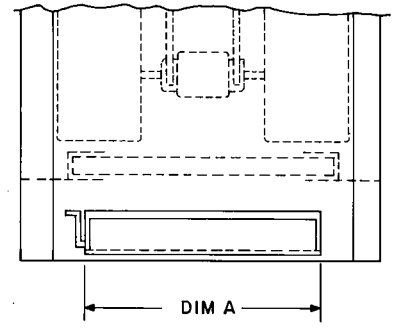

BACK VIEW

NOTE: A 6-in. diameter outside air opening with duct collar and filter is available for 42CE,CF,CG,CK,VA,VB, and VF units. It is also available with a round damper.

42C, V Series Units

Accessory dimensions (cont)



42C OPTIONAL COIL CONNECTION LOCATION SIZE 02 THRU 12

NOTES:

1. Right hand unit shown; left hand unit opposite.
2. All dimensions are in inches ±1/4 inch.
3. Dimensions do not apply to units with factory valve packages.
4. All connection sizes 5/8" O.D.

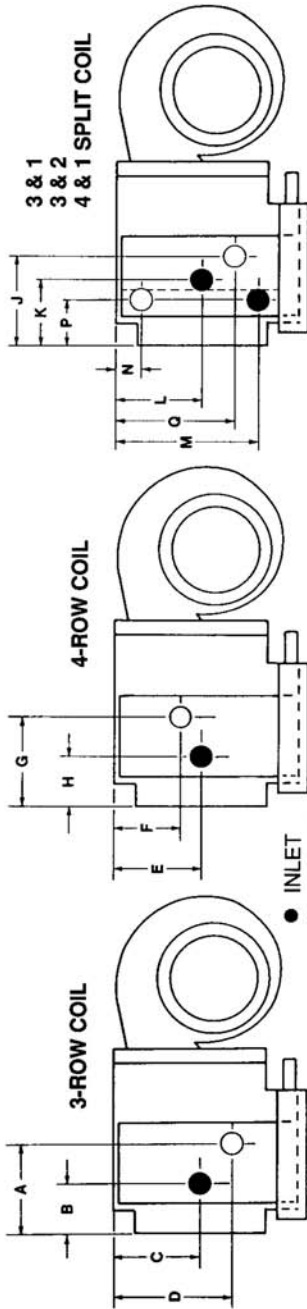

COIL CONNECTION DIMENSIONS

R I G H T H A N D	3-ROW COIL			4-ROW COIL			3 AND 1 SPLIT COIL			3 AND 2 SPLIT COIL					
	A	B	C	D	E	F	G	H	J	K	L	M	N	P	Q
02	43/4	25/8	41/4	41/4	35/8	41/4	59/16	21/16	59/16	31/8	41/4	55/8	11/8	21/16	41/4
03	43/4	25/8	41/4	41/4	35/8	41/4	59/16	21/16	59/16	31/8	41/4	55/8	11/8	21/16	41/4
04	43/4	25/8	41/4	41/4	35/8	41/4	59/16	21/16	59/16	31/8	41/4	55/8	11/8	21/16	41/4
06	43/4	25/8	35/8	47/8	51/2	47/8	59/16	21/16	59/16	31/8	47/8	67/8	23/8	21/16	47/8
08	43/4	25/8	35/8	47/8	35/8	41/4	59/16	21/16	59/16	31/8	47/8	67/8	23/8	21/16	47/8
10	43/4	25/8	47/8	35/8	41/4	47/8	59/16	21/16	59/16	31/8	51/2	67/8	23/8	21/16	41/4
12	43/4	25/8	47/8	35/8	41/4	47/8	59/16	21/16	59/16	31/8	51/2	67/8	23/8	21/16	41/4

R I G H T H A N D	3 AND 2 SPLIT COIL			4 AND 1 SPLIT COIL			UNIT SIZE			4 AND 1 SPLIT COIL						
	J	K	L	M	N	P	Q	R	I	G	H	T	H	A	N	D
02	65/16	41/8	41/4	55/8	13/4	211/16	41/4	53/16	25/8	41/4	55/8	11/8	19/16	19/16	19/16	41/4
03	65/16	41/8	41/4	55/8	13/4	211/16	41/4	53/16	25/8	41/4	55/8	11/8	19/16	19/16	19/16	41/4
04	65/16	41/8	41/4	55/8	13/4	211/16	41/4	53/16	25/8	41/4	55/8	11/8	19/16	19/16	19/16	41/4
06	65/16	41/8	47/8	67/8	3	211/16	47/8	53/16	25/8	47/8	67/8	23/8	19/16	19/16	19/16	47/8
08	65/16	41/8	47/8	67/8	3	211/16	47/8	53/16	25/8	47/8	67/8	23/8	19/16	19/16	19/16	47/8
10	65/16	41/8	51/2	67/8	3	211/16	41/4	53/16	25/8	51/2	67/8	23/8	19/16	19/16	19/16	41/4
12	65/16	41/8	51/2	67/8	3	211/16	47/8	53/16	25/8	51/2	67/8	23/8	19/16	19/16	19/16	41/4

L E F T H A N D	3-ROW COIL			4-ROW COIL			3 AND 1 SPLIT COIL			3 AND 2 SPLIT COIL					
	A	B	C	D	E	F	G	H	J	K	L	M	N	P	Q
02	43/4	25/8	41/4	41/4	41/4	35/8	59/16	21/16	59/16	31/8	35/8	5	1/2	21/16	35/8
03	43/4	25/8	41/4	41/4	41/4	35/8	59/16	21/16	59/16	31/8	35/8	5	1/2	21/16	35/8
04	43/4	25/8	41/4	41/4	41/4	35/8	59/16	21/16	59/16	31/8	35/8	5	1/2	21/16	35/8
06	43/4	25/8	47/8	35/8	47/8	51/2	59/16	21/16	59/16	31/8	41/4	63/4	1/2	21/16	41/4
08	43/4	25/8	47/8	35/8	47/8	35/8	59/16	21/16	59/16	31/8	41/4	63/4	1/2	21/16	41/4
10	43/4	25/8	47/8	35/8	47/8	41/2	59/16	21/16	59/16	31/8	35/8	63/4	1/2	21/16	47/8
12	43/4	25/8	35/8	47/8	47/8	41/2	59/16	21/16	59/16	31/8	35/8	63/4	1/2	21/16	47/8

L E F T H A N D	3 AND 2 SPLIT COIL			4 AND 1 SPLIT COIL			UNIT SIZE			
	J	K	L	M	N	P	Q	R	I	G
02	65/16	41/8	35/8	5	1/8	211/16	35/8	53/16	25/8	41/4
03	65/16	41/8	35/8	5	1/8	211/16	35/8	53/16	25/8	41/4
04	65/16	41/8	35/8	5	1/8	211/16	35/8	53/16	25/8	41/4
06	65/16	41/8	41/4	63/4	1/8	211/16	41/4	53/16	25/8	41/4
08	65/16	41/8	41/4	63/4	1/8	211/16	41/4	53/16	25/8	41/4
10	65/16	41/8	35/8	63/4	1/8	211/16	47/8	53/16	25/8	41/4
12	65/16	41/8	35/8	63/4	1/8	211/16	47/8	53/16	25/8	41/4

L E F T H A N D	4 AND 1 SPLIT COIL			UNIT SIZE			4 AND 1 SPLIT COIL			
	J	K	L	M	N	P	Q	R	I	G
02	53/16	25/8	35/8	5	1/2	19/16	35/8	53/16	25/8	41/4
03	53/16	25/8	35/8	5	1/2	19/16	35/8	53/16	25/8	41/4
04	53/16	25/8	35/8	5	1/2	19/16	35/8	53/16	25/8	41/4
06	53/16	25/8	41/4	63/4	1/2	19/16	41/4	53/16	25/8	41/4
08	53/16	25/8	41/4	63/4	1/2	19/16	41/4	53/16	25/8	41/4
10	53/16	25/8	35/8	63/4	1/2	19/16	47/8	53/16	25/8	41/4
12	53/16	25/8	35/8	63/4	1/2	19/16	47/8	53/16	25/8	41/4

42VA, VB, VF OPTIONAL COIL CONNECTION LOCATION SIZE 02 THRU 12

RIGHT HAND

LEFT HAND

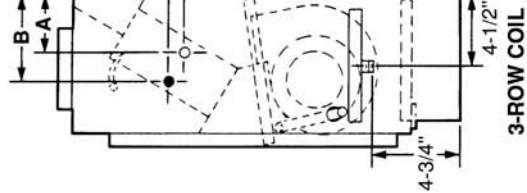

3-ROW COIL

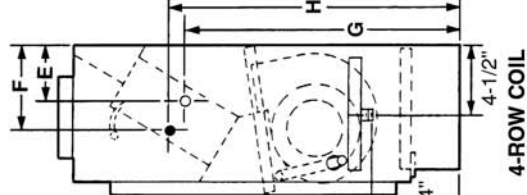

4-ROW COIL

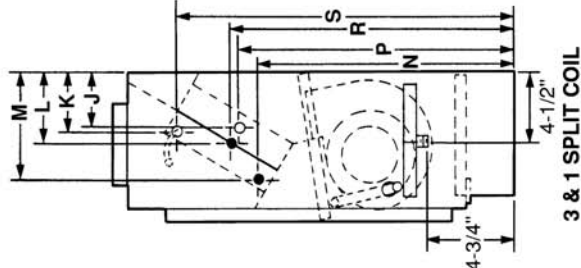

3 & 1 SPLIT COIL
3 & 2 SPLIT COIL
4 & 1 SPLIT COIL

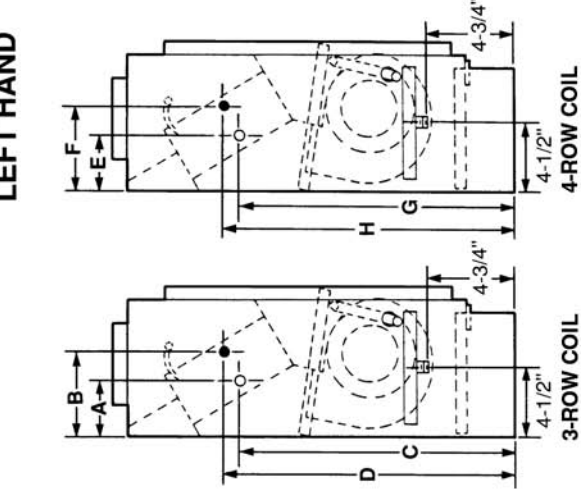

3-ROW COIL

4-ROW COIL

3 & 1 SPLIT COIL
3 & 2 SPLIT COIL
4 & 1 SPLIT COIL

● INLET
○ OUTLET ± 5/8"

● INLET
○ OUTLET ± 5/8"

NOTES:

- Dimensions for split coils with opposite end connections will vary.
- Coil connection dimensions are for coils stub outs only. Valve packages not included.
- All dimensions are in inches.

COIL CONNECTION DIMENSIONS

R I G H T H A N D	3-ROW COIL			4-ROW COIL			3 AND 1 SPLIT COIL										
	UNIT SIZE	A	B	C	D	E	F	G	H	J	K	L	M	N	P	R	S
02	4	5 ⁵ / ₁₆	17 ¹ / ₁₆	18 ¹ / ₁₆	31 ¹ / ₂	6 ¹ / ₄	16 ⁷ / ₁₆	19 ¹ / ₈	39 ¹ / ₁₆	47 ¹ / ₈	51 ¹ / ₂	8	15 ⁷ / ₈	16 ⁷ / ₈	18	21 ¹ / ₄	
03	4	5 ⁵ / ₁₆	17 ¹ / ₁₆	18 ¹ / ₁₆	31 ¹ / ₂	6 ¹ / ₄	16 ⁷ / ₁₆	19 ¹ / ₈	39 ¹ / ₁₆	47 ¹ / ₈	51 ¹ / ₂	8	15 ⁷ / ₈	16 ⁷ / ₈	18	21 ¹ / ₄	
04	4	5 ⁵ / ₁₆	17 ¹ / ₁₆	18 ¹ / ₁₆	31 ¹ / ₂	6 ¹ / ₄	16 ⁷ / ₁₆	19 ¹ / ₈	39 ¹ / ₁₆	47 ¹ / ₈	51 ¹ / ₂	8	15 ⁷ / ₈	16 ⁷ / ₈	18	21 ¹ / ₄	
06	3 ¹ / ₁₆	5 ⁵ / ₁₆	17 ⁵ / ₁₆	18 ¹ / ₁₆	31 ¹ / ₂	6 ¹ / ₄	17 ¹ / ₁₆	19 ¹ / ₈	39 ¹ / ₁₆	47 ¹ / ₈	53 ¹ / ₈	8	15 ⁷ / ₈	17 ¹ / ₁₆	18 ¹ / ₂	21 ¹ / ₄	
08	3 ¹ / ₁₆	5	17 ⁵ / ₁₆	18 ¹ / ₁₆	31 ¹ / ₂	6 ¹ / ₄	18	20 ⁹ / ₁₆	39 ¹ / ₁₆	47 ¹ / ₈	53 ¹ / ₈	8	15 ⁷ / ₈	17 ¹ / ₁₆	18 ¹ / ₂	21 ¹ / ₄	
10	3 ¹ / ₁₆	5 ⁵ / ₁₆	18 ³ / ₄	18 ¹ / ₁₆	31 ¹ / ₂	5 ⁷ / ₈	17 ¹ / ₁₆	19 ¹ / ₈	39 ¹ / ₁₆	47 ¹ / ₈	6	8	15 ⁷ / ₈	18	18 ¹ / ₂	21 ¹ / ₄	
12	3 ¹ / ₁₆	5 ⁵ / ₁₆	18 ³ / ₄	18 ¹ / ₁₆	31 ¹ / ₂	5 ⁷ / ₈	17 ¹ / ₁₆	19 ¹ / ₈	39 ¹ / ₁₆	47 ¹ / ₈	6	8	15 ⁷ / ₈	18	18 ¹ / ₂	21 ¹ / ₄	

COIL CONNECTION DIMENSIONS

L E F T H A N D	3-ROW COIL			4-ROW COIL			3 AND 1 SPLIT COIL										
	UNIT SIZE	A	B	C	D	E	F	G	H	J	K	L	M	N	P	R	S
02	4	5 ⁵ / ₁₆	17 ¹ / ₁₆	18 ¹ / ₁₆	31 ¹ / ₂	6 ¹ / ₄	17 ¹ / ₁₆	18 ⁵ / ₁₆	31 ¹ / ₄	45 ⁵ / ₈	53 ⁵ / ₁₆	7 ³ / ₄	16 ⁷ / ₁₆	17 ¹ / ₁₆	18 ¹ / ₂	21 ¹ / ₈	
03	4	5 ⁵ / ₁₆	17 ¹ / ₁₆	18 ¹ / ₁₆	31 ¹ / ₂	6 ¹ / ₄	17 ¹ / ₁₆	18 ⁵ / ₁₆	31 ¹ / ₄	45 ⁵ / ₈	53 ⁵ / ₁₆	7 ³ / ₄	16 ⁷ / ₁₆	17 ¹ / ₁₆	18 ¹ / ₂	21 ¹ / ₈	
04	4	5 ⁵ / ₁₆	17 ¹ / ₁₆	18 ¹ / ₁₆	31 ¹ / ₂	6 ¹ / ₄	17 ¹ / ₁₆	18 ⁵ / ₁₆	31 ¹ / ₄	45 ⁵ / ₈	53 ⁵ / ₁₆	7 ³ / ₄	16 ⁷ / ₁₆	17 ¹ / ₁₆	18 ¹ / ₂	21 ¹ / ₈	
06	3 ¹ / ₁₆	5 ⁵ / ₁₆	17 ⁵ / ₁₆	18 ¹ / ₁₆	31 ¹ / ₂	6 ¹ / ₄	16 ⁷ / ₁₆	19 ¹ / ₈	31 ¹ / ₄	45 ⁵ / ₈	51 ¹ / ₂	7 ³ / ₄	16 ⁷ / ₁₆	16 ⁷ / ₁₆	18	21 ¹ / ₈	
08	3	5 ⁵ / ₁₆	18 ¹ / ₁₆	18 ¹ / ₁₆	29 ¹ / ₁₆	5 ⁷ / ₈	18 ¹ / ₂	19 ⁵ / ₁₆	27 ¹ / ₈	31 ⁵ / ₁₆	47 ¹ / ₈	7 ¹ / ₈	17 ¹ / ₂	18	19 ¹ / ₈	23	
10	3 ¹ / ₁₆	5	17 ⁵ / ₁₆	19 ¹ / ₁₆	41 ¹ / ₂	6 ³ / ₈	18	19 ¹ / ₈	31 ¹ / ₄	31 ⁵ / ₁₆	41 ¹ / ₂	7 ¹ / ₈	17 ¹ / ₂	17 ¹ / ₁₆	19 ⁵ / ₈	23	
12	3 ¹ / ₁₆	5	17 ⁵ / ₁₆	19 ¹ / ₁₆	41 ¹ / ₂	6 ³ / ₈	18	19 ¹ / ₈	31 ¹ / ₄	31 ⁵ / ₁₆	41 ¹ / ₂	7 ¹ / ₈	17 ¹ / ₂	17 ¹ / ₁₆	19 ⁵ / ₈	23	

R I G H T H A N D	3 AND 2 SPLIT COIL						4 AND 1 SPLIT COIL										
	UNIT SIZE	J	K	L	M	N	P	R	S	J	K	L	M	N	P	R	S
02	4	7 ¹ / ₄	5 ¹ / ₂	8 ⁵ / ₈	16 ⁷ / ₁₆	16 ⁷ / ₁₆	16 ⁷ / ₁₆	17 ¹ / ₁₆	18 ⁵ / ₈	31 ¹ / ₂	6	6 ¹ / ₄	7 ³ / ₄	16 ⁷ / ₁₆	16 ⁷ / ₁₆	19 ¹ / ₈	21 ⁷ / ₈
03	4	7 ¹ / ₄	5 ¹ / ₂	8 ⁵ / ₈	16 ⁷ / ₁₆	16 ⁷ / ₁₆	16 ⁷ / ₁₆	17 ¹ / ₁₆	18 ⁵ / ₈	31 ¹ / ₂	6	6 ¹ / ₄	7 ³ / ₄	16 ⁷ / ₁₆	16 ⁷ / ₁₆	19 ¹ / ₈	21 ⁷ / ₈
04	4	7 ¹ / ₄	5 ¹ / ₂	8 ⁵ / ₈	16 ⁷ / ₁₆	16 ⁷ / ₁₆	16 ⁷ / ₁₆	17 ¹ / ₁₆	18 ⁵ / ₈	31 ¹ / ₂	6	6 ¹ / ₄	7 ³ / ₄	16 ⁷ / ₁₆	16 ⁷ / ₁₆	19 ¹ / ₈	21 ⁷ / ₈
06	3 ¹ / ₁₆	5 ⁹ / ₁₆	5 ⁹ / ₁₆	8 ¹ / ₁₆	16 ⁷ / ₁₆	17 ¹ / ₁₆	17 ¹ / ₁₆	16 ⁷ / ₁₆	19 ¹ / ₈	31 ¹ / ₂	6	6 ¹ / ₄	7 ³ / ₄	16 ⁷ / ₁₆	16 ⁷ / ₁₆	18 ⁵ / ₈	21 ⁷ / ₈
08	3	8 ¹ / ₁₆	5 ³ / ₁₆	7 ¹ / ₂	17 ¹ / ₁₆	17 ¹ / ₁₆	17 ¹ / ₁₆	18 ¹ / ₂	19 ⁵ / ₁₆	27 ¹ / ₈	5 ¹ / ₂	5 ⁹ / ₁₆	8 ¹ / ₁₆	17 ¹ / ₂	18	20 ³ / ₁₆	23
10	3 ¹ / ₁₆	7 ⁹ / ₈	6	6 ³ / ₄	17 ¹ / ₂	18	18	19 ¹ / ₈	19 ¹ / ₈	31 ¹ / ₂	5 ³ / ₄	5 ⁷ / ₈	8 ¹ / ₂	17 ¹ / ₂	17 ¹ / ₁₆	19 ⁵ / ₈	23
12	3 ¹ / ₁₆	7 ⁹ / ₈	6	6 ³ / ₄	17 ¹ / ₂	18	18	19 ¹ / ₈	19 ¹ / ₈	31 ¹ / ₂	5 ³ / ₄	5 ⁷ / ₈	8 ¹ / ₂	17 ¹ / ₂	17 ¹ / ₁₆	19 ⁵ / ₈	23

L E F T H A N D	3 AND 2 SPLIT COIL						4 AND 1 SPLIT COIL										
	UNIT SIZE	J	K	L	M	N	P	R	S	J	K	L	M	N	P	R	S
02	4	6	5 ¹ / ₂	8 ³ / ₈	16 ⁷ / ₁₆	16 ⁷ / ₁₆	16 ⁷ / ₁₆	17 ¹ / ₁₆	18 ⁵ / ₈	31 ¹ / ₂	6	6 ¹ / ₄	9	17 ¹ / ₈	16 ⁷ / ₁₆	19 ¹ / ₈	22 ¹ / ₂
03	4	6	5 ¹ / ₂	8 ³ / ₈	16 ⁷ / ₁₆	16 ⁷ / ₁₆	16 ⁷ / ₁₆	17 ¹ / ₁₆	18 ⁵ / ₈	31 ¹ / ₂	6	6 ¹ / ₄	9	17 ¹ / ₈	16 ⁷ / ₁₆	19 ¹ / ₈	22 ¹ / ₂
04	4	6	5 ¹ / ₂	8 ³ / ₈	16 ⁷ / ₁₆	16 ⁷ / ₁₆	16 ⁷ / ₁₆	17 ¹ / ₁₆	18 ⁵ / ₈	31 ¹ / ₂	6	6 ¹ / ₄	9	17 ¹ / ₈	16 ⁷ / ₁₆	19 ¹ / ₈	22 ¹ / ₂
06	3 ¹ / ₁₆	6	5 ⁹ / ₁₆	8 ¹ / ₁₆	16 ⁷ / ₁₆	16 ⁷ / ₁₆	16 ⁷ / ₁₆	16 ⁷ / ₁₆	19 ¹ / ₈	31 ¹ / ₂	6	6 ¹ / ₄	9	17 ¹ / ₈	17 ¹ / ₁₆	18 ⁵ / ₈	22 ¹ / ₂
08	3	6	5 ⁹ / ₁₆	7 ¹ / ₂	17 ¹ / ₁₆	17 ¹ / ₁₆	17 ¹ / ₁₆	18 ¹ / ₂	19 ⁵ / ₁₆	27 ¹ / ₈	5 ¹ / ₂	5 ⁹ / ₁₆	9	17 ¹ / ₈	18	20 ³ / ₁₆	22 ¹ / ₂
10	3 ¹ / ₁₆	6	6	6 ³ / ₄	17 ¹ / ₂	18	18	19 ¹ / ₈	19 ¹ / ₈	31 ¹ / ₂	6	6 ¹ / ₄	9	17 ¹ / ₈	17 ¹ / ₁₆	19 ⁵ / ₈	22 ¹ / ₂
12	3 ¹ / ₁₆	6	6	6 ³ / ₄	17 ¹ / ₂	18	18	19 ¹ / ₈	19 ¹ / ₈	31 ¹ / ₂	6	6 ¹ / ₄	9	17 ¹ / ₈	17 ¹ / ₁₆	19 ⁵ / ₈	22 ¹ / ₂

Accessory dimensions (cont)



42VC,VE OPTIONAL COIL CONNECTION LOCATION SIZE 02 THRU 06

42C,V Series Units

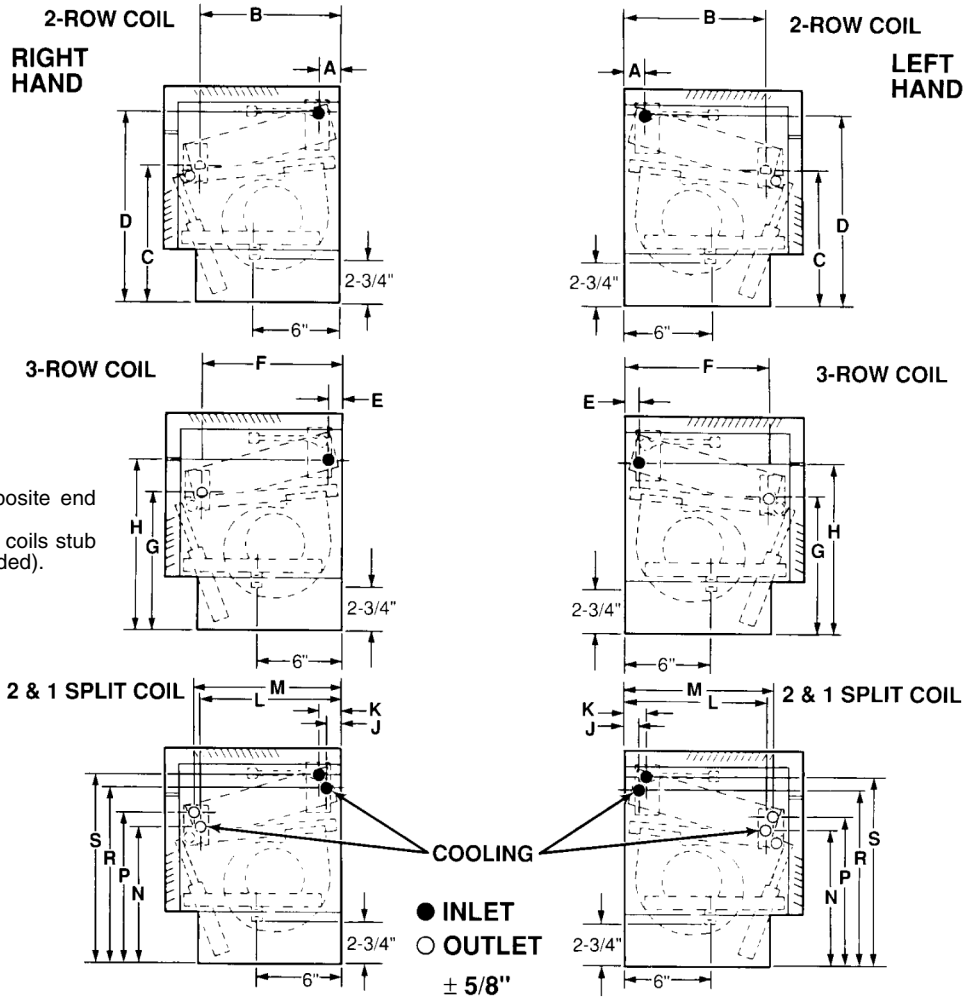

NOTES:

1. Dimensions for split coils with opposite end connections will vary.
2. Coil connection dimensions are for coils stub outs only (valve packages not included).
3. All dimensions are in inches.

COIL CONNECTION DIMENSIONS

	UNIT SIZE	23-ROW COIL				3-ROW COIL				2 AND 1 SPLIT COIL							
		A	B	C	D	E	F	G	H	J	K	L	M	N	P	R	S
RIGHT HAND	02	1	10 ³ / ₈	10 ⁷ / ₁₆	11 ¹ / ₄	1 ⁵ / ₁₆	10	8 ³ / ₈	12 ¹ / ₂	7 ⁷ / ₈	1 ¹⁵ / ₁₆	10 ¹ / ₈	9 ³ / ₄	9 ¹ / ₂	10 ⁹ / ₁₆	10 ¹ / ₄	12 ³ / ₈
	03	1	10 ³ / ₈	10 ⁷ / ₁₆	11 ¹ / ₄	1 ⁵ / ₁₆	10	8 ³ / ₈	12 ¹ / ₂	7 ⁷ / ₈	1 ¹⁵ / ₁₆	10 ¹ / ₈	9 ³ / ₄	9 ¹ / ₂	10 ⁹ / ₁₆	10 ¹ / ₄	12 ³ / ₈
	04	1	10 ³ / ₈	10 ⁷ / ₁₆	11 ¹ / ₄	1 ¹ / ₂	9 ³ / ₄	8 ¹⁵ / ₁₆	11 ⁷ / ₈	7 ⁷ / ₈	1 ¹⁵ / ₁₆	10 ¹ / ₈	9 ³ / ₄	9 ¹ / ₂	10 ⁹ / ₁₆	10 ¹ / ₄	12 ³ / ₈
	06	1 ¹ / ₄	10	10	11 ³ / ₄	1 ¹ / ₂	9 ³ / ₄	8 ¹⁵ / ₁₆	11 ⁷ / ₈	1 ¹ / ₄	1 ¹⁵ / ₁₆	9 ³ / ₄	9 ³ / ₄	8 ¹⁵ / ₁₆	10 ⁹ / ₁₆	10 ³ / ₄	12 ³ / ₈
LEFT HAND	02	1 ¹ / ₄	10 ³ / ₁₆	9 ¹ / ₄	12 ³ / ₈	1 ⁵ / ₁₆	10	8 ³ / ₈	12 ¹ / ₂	1 ¹ / ₁₆	1 ¹⁵ / ₁₆	10	10 ³ / ₈	10 ³ / ₈	10 ¹ / ₂	11 ³ / ₈	12 ³ / ₈
	03	1 ¹ / ₄	10 ³ / ₁₆	9 ¹ / ₄	12 ³ / ₈	1 ⁵ / ₁₆	10	8 ³ / ₈	12 ¹ / ₂	1 ¹ / ₁₆	1 ¹⁵ / ₁₆	10	10 ³ / ₈	8 ³ / ₈	10 ¹ / ₂	11 ³ / ₈	12 ³ / ₈
	04	1 ¹ / ₄	10 ³ / ₁₆	9 ¹ / ₄	12 ³ / ₈	1 ¹ / ₄	10	10	10 ³ / ₄	1 ¹ / ₁₆	1 ¹⁵ / ₁₆	10	10 ³ / ₈	8 ³ / ₈	10 ¹ / ₂	11 ³ / ₈	12 ³ / ₈
	06	1 ⁷ / ₁₆	10	10	11 ³ / ₄	1 ¹ / ₄	10	10	10 ³ / ₄	1 ¹ / ₄	1 ¹⁵ / ₁₆	9 ³ / ₄	10 ⁷ / ₁₆	8 ¹⁵ / ₁₆	10 ¹ / ₂	10 ³ / ₄	12 ³ / ₈

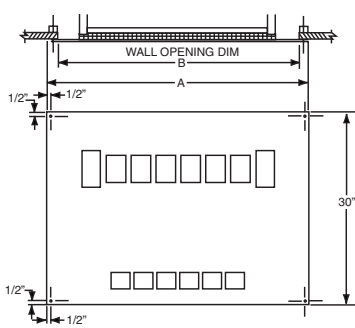
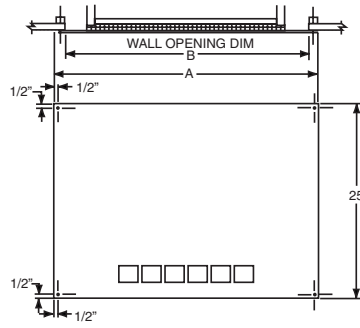
DECORATIVE WALL PANELS (42VA units only)

Front Return and Supply with Access Doors

Front Return Top Supply

UNIT SIZE	CFM	A (in.)	B (in.)
02	200	40	38 ¹ / ₄
03	300	44	42 ¹ / ₄
04	400	50	48 ¹ / ₄
06	600	60	58 ¹ / ₄
08	800	62	60 ¹ / ₄
10	1000	76	74 ¹ / ₄
12	1200	84	82 ¹ / ₄

SUPPLY GRILLES

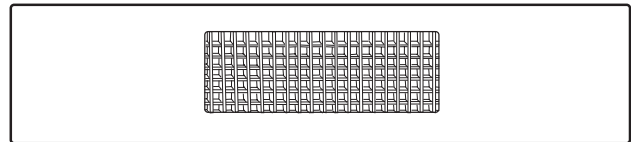
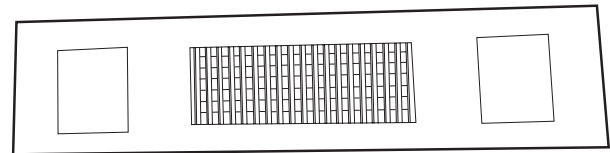
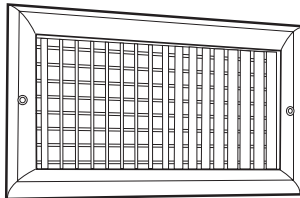
SUPPLY GRILLES						
Unit Size	Nominal Airflow (Cfm)	Recommended Grille Sizes (in.)				
		Model				
		42C*	42VA*	42VB,VF	42VC*	42VE
02	200	16 x 6	16 x 5	16 x 6	16 x 5	16 x 6
03	300	20 x 6	20 x 5	20 x 6	22 x 5	22 x 6
04	400	26 x 6	26 x 5	26 x 6	30 x 5	30 x 6
06	600	30 x 6	30 x 5	36 x 6	44 x 5	44 x 6
08	800	38 x 6	38 x 5	38 x 6	—	—
10	1000	52 x 6	52 x 5	52 x 6	—	—
12	1200	60 x 6	60 x 5	60 x 6	—	—

*Refer to unit dimensions to size field transitions.

INTEGRAL DOUBLE-DEFLECTION GRILLE FOR HORIZONTAL UNITS (Installed on 42CG unit as shown)

INTEGRAL DOUBLE-DEFLECTION GRILLE FOR VERTICAL UNITS (Installed on 42VB unit as shown)

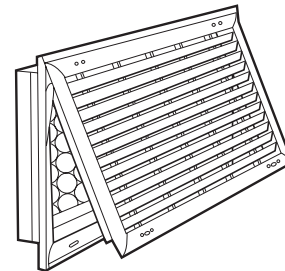
ANODIZED ALUMINUM DOUBLE-DEFLECTION GRILLE (With frame)

RETURN AIR GRILLES

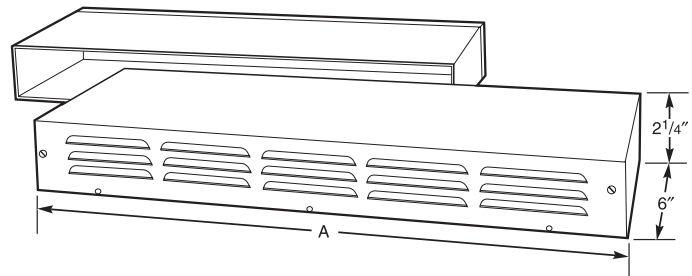
RETURN GRILLE SIZES		
Unit Size	Nominal Airflow (Cfm)	Recommended Grille Size (in.)
02	200	24 x 10
03	300	28 x 10
04	400	32 x 10
06	600	42 x 10
08	800	42 x 10
10	1000	54 x 10
12	1200	64 x 10

HINGED BAR-TYPE GRILLE

WALL BOXES

UNIT SIZE	NOMINAL AIRFLOW (Cfm)	DIMENSION A (in.)
02	200	8 ¹ / ₄
03	300	10 ¹ / ₄
04	400	12 ¹ / ₄
06	600	14 ¹ / ₄
08	800	18 ¹ / ₄
10	1000	27 ¹ / ₄
12	1200	27 ¹ / ₄





42CA,CE,CF,CG,CK,VA,VB,VF COOLING CAPACITY (by ΔT) 3-ROW COIL

Table with columns for UNIT SIZE, ΔT, and cooling capacity for three coil types (75 F DB/63 F WB, 80 F DB/67 F WB, 85 F DB/71 F WB) across various sub-coil types (40, 45, 50 F EWT).

42C,V Series Units

42CA,CE,CF,CG,CK,VA,VB,VF COOLING CAPACITY (by ΔT) 4-ROW COIL

Table with columns for UNIT SIZE, ΔT, and cooling capacity for three coil types (75 F DB/63 F WB, 80 F DB/67 F WB, 85 F DB/71 F WB) across various sub-coil types (40, 45, 50 F EWT).

LEGEND

- ΔT — Temperature Change
DB — Dry Bulb
EWT — Entering Water Temperature
GPM — Gallons Per Minute
SCb — Base Sensible Capacity from Base Cooling Capacities by Gpm charts
TCb — Base Total Capacity from Base Cooling Capacities by Gpm charts
WB — Wet Bulb

NOTE: All capacities are given in thousands of Btuh (MBtuh).

Performance data (cont)



AIR DELIVERY (CFM) 42CA — 60 Hz MOTOR

42C,V Series Units

UNIT SIZE	COIL ROWS	FAN SPEED	EXTERNAL STATIC PRESSURE (in. wg)						
			0.00	0.05	0.10	0.15	0.20	0.25	0.30
02	3	High	220	205	185	160	—	—	—
		Med	195	185	150	—	—	—	—
		Low	175	150	—	—	—	—	—
	4	High	215	200	175	140	—	—	—
		Med	190	175	—	—	—	—	—
		Low	165	140	—	—	—	—	—
	5	High	205	190	160	—	—	—	—
		Med	180	165	—	—	—	—	—
		Low	155	—	—	—	—	—	—
03	3	High	330	300	265	225	170	—	—
		Med	295	265	230	—	—	—	—
		Low	250	215	180	—	—	—	—
	4	High	320	290	250	205	150	—	—
		Med	285	255	215	—	—	—	—
		Low	240	205	105	—	—	—	—
	5	High	300	270	235	195	—	—	—
		Med	270	240	200	—	—	—	—
		Low	230	195	—	—	—	—	—
04	3	High	510	480	450	415	370	290	—
		Med	360	320	300	260	—	—	—
		Low	220	180	160	—	—	—	—
	4	High	500	470	440	400	340	240	—
		Med	305	285	265	225	—	—	—
		Low	215	175	155	—	—	—	—
	5	High	490	460	430	390	325	230	—
		Med	295	255	235	200	—	—	—
		Low	210	170	—	—	—	—	—
06	3	High	760	720	670	620	560	475	—
		Med	540	510	460	410	—	—	—
		Low	330	295	250	—	—	—	—
	4	High	745	700	650	590	525	430	—
		Med	530	500	450	400	—	—	—
		Low	295	260	—	—	—	—	—
	5	High	725	680	630	570	525	410	—
		Med	520	490	440	385	—	—	—
		Low	290	255	—	—	—	—	—

NOTE: Air delivery is based on operation with dry coils and clean air filter.



AIR DELIVERY (CFM) (cont)
42CA — 60 Hz MOTOR (cont)

UNIT SIZE	COIL ROWS	FAN SPEED	EXTERNAL STATIC PRESSURE (in. wg)						
			0.00	0.05	0.10	0.15	0.20	0.25	0.30
08	3	High	870	840	800	760	700	620	—
		Med	590	560	515	460	—	—	—
		Low	335	300	255	—	—	—	—
	4	High	860	825	780	730	665	575	—
		Med	585	555	510	455	—	—	—
		Low	330	295	250	—	—	—	—
	5	High	850	810	760	700	630	530	—
		Med	575	535	500	445	—	—	—
		Low	325	290	245	—	—	—	—
10	3	High	1100	1060	1010	930	845	730	—
		Med	665	610	545	475	—	—	—
		Low	495	430	375	—	—	—	—
	4	High	1085	1040	970	895	800	670	—
		Med	655	600	535	465	—	—	—
		Low	480	415	360	—	—	—	—
	5	High	1070	1025	955	880	785	655	—
		Med	645	590	525	455	—	—	—
		Low	470	405	350	—	—	—	—
12	3	High	1425	1370	1310	1240	1160	1055	—
		Med	950	900	810	760	675	—	—
		Low	705	555	495	405	—	—	—
	4	High	1400	1345	1280	1205	1115	990	—
		Med	930	880	790	740	655	—	—
		Low	690	540	480	390	—	—	—
	5	High	1375	1320	1255	1180	1090	965	—
		Med	910	860	770	720	635	—	—
		Low	675	525	465	375	—	—	—

NOTE: Air delivery is based on operation with dry coils and clean air filter.

42C, V Series Units

Performance data (cont)



AIR DELIVERY (CFM) (cont) 42CE,CG,CK — 60 Hz MOTOR

42C,V Series Units

UNIT SIZE	COIL ROWS	FAN SPEED	EXTERNAL STATIC PRESSURE (in. wg)						
			0.00	0.05	0.10	0.15	0.20	0.25	0.30
02	3	High	190	180	170	145	—	—	—
		Med	175	145	120	—	—	—	—
		Low	150	120	100	—	—	—	—
	4	High	185	180	160	125	—	—	—
		Med	170	140	115	—	—	—	—
		Low	145	115	—	—	—	—	—
	5	High	170	160	140	—	—	—	—
		Med	155	125	—	—	—	—	—
		Low	140	105	—	—	—	—	—
03	3	High	300	275	250	215	165	—	—
		Med	270	230	190	—	—	—	—
		Low	215	175	145	—	—	—	—
	4	High	290	270	240	195	—	—	—
		Med	260	220	180	—	—	—	—
		Low	205	165	—	—	—	—	—
	5	High	280	260	230	185	—	—	—
		Med	250	215	—	—	—	—	—
		Low	200	160	—	—	—	—	—
04	3	High	470	445	415	380	320	250	—
		Med	275	230	200	—	—	—	—
		Low	205	175	—	—	—	—	—
	4	High	460	435	400	355	300	210	—
		Med	270	225	195	—	—	—	—
		Low	200	170	—	—	—	—	—
	5	High	445	420	385	340	285	—	—
		Med	265	220	190	—	—	—	—
		Low	195	165	—	—	—	—	—
06	3	High	690	655	615	560	500	410	—
		Med	450	410	370	330	—	—	—
		Low	280	240	205	—	—	—	—
	4	High	675	635	595	535	465	355	—
		Med	440	400	360	320	—	—	—
		Low	220	190	—	—	—	—	—
	5	High	660	620	570	520	450	340	—
		Med	430	390	350	310	—	—	—
		Low	200	180	—	—	—	—	—

NOTE: Air delivery is based on operation with dry coils and clean air filter.



AIR DELIVERY (CFM) (cont)
42CE,CG,CK — 60 Hz MOTOR (cont)

UNIT SIZE	COIL ROWS	FAN SPEED	EXTERNAL STATIC PRESSURE (in. wg)						
			0.00	0.05	0.10	0.15	0.20	0.25	0.30
08	3	High	835	800	760	710	650	570	—
		Med	565	520	475	430	—	—	—
		Low	335	295	255	—	—	—	—
	4	High	815	780	740	685	615	515	—
		Med	550	505	460	415	—	—	—
		Low	325	285	245	—	—	—	—
	5	High	800	760	715	660	575	—	—
		Med	540	495	450	405	—	—	—
		Low	315	275	235	—	—	—	—
10	3	High	1045	995	940	880	805	710	—
		Med	630	565	500	430	—	—	—
		Low	485	410	330	—	—	—	—
	4	High	1020	970	915	850	765	645	—
		Med	615	550	485	415	—	—	—
		Low	475	400	320	—	—	—	—
	5	High	1000	945	885	815	720	—	—
		Med	600	535	470	400	—	—	—
		Low	465	390	—	—	—	—	—
12	3	High	1300	1240	1180	1110	1025	920	840
		Med	900	845	790	740	685	—	—
		Low	540	470	400	330	—	—	—
	4	High	1275	1215	1150	1075	980	850	815
		Med	880	825	770	720	665	—	—
		Low	530	460	390	320	—	—	—
	5	High	1250	1190	1125	1050	955	825	790
		Med	870	815	760	710	655	—	—
		Low	520	450	380	310	—	—	—

NOTE: Air delivery is based on operation with dry coils and clean air filter.

42C, V Series Units

Performance data (cont)



AIR DELIVERY (CFM) (cont) 42CF — 60 Hz MOTOR

42C,V Series Units

UNIT SIZE	COIL ROWS	FAN SPEED	EXTERNAL STATIC PRESSURE (in. wg)						
			0.00	0.05	0.10	0.15	0.20	0.25	0.30
04	3	High	530	540	505	465	420	360	285
		Med	535	505	470	420	365	—	—
		Low	485	455	430	—	—	—	—
	4	High	555	520	485	445	390	330	—
		Med	525	495	460	410	365	—	—
		Low	420	390	360	—	—	—	—
	5	High	540	510	470	425	365	290	—
		Med	515	485	450	400	—	—	—
		Low	400	370	340	—	—	—	—
06	3	High	720	680	635	585	530	460	385
		Med	640	600	555	505	450	380	—
		Low	540	500	455	405	—	—	—
	4	High	700	660	610	560	500	430	340
		Med	625	585	540	490	435	—	—
		Low	525	485	440	390	—	—	—
	5	High	680	640	590	540	480	410	320
		Med	605	565	520	470	—	—	—
		Low	515	475	430	380	—	—	—
08	3	High	800	750	695	640	580	515	440
		Med	660	610	555	500	440	375	—
		Low	545	495	430	385	225	—	—
	4	High	780	725	670	615	555	485	395
		Med	645	590	535	480	425	350	—
		Low	535	485	420	375	—	—	—
	5	High	760	705	650	595	525	465	—
		Med	625	575	520	465	410	—	—
		Low	525	475	410	365	—	—	—
10	3	High	1295	1215	1130	1045	960	865	700
		Med	1195	1115	1030	945	860	—	—
		Low	1060	980	900	820	—	—	—
	4	High	1260	1175	1090	1005	915	810	700
		Med	1165	1095	1010	925	—	—	—
		Low	1035	955	875	800	—	—	—
	5	High	1235	1150	1065	980	890	790	655
		Med	1145	1075	990	905	—	—	—
		Low	1015	935	855	—	—	—	—

NOTE: Air delivery is based on operation with dry coils and clean air filter.



AIR DELIVERY (CFM) (cont)
42VA,VB,VF — 60 Hz MOTOR

42C, V Series Units

UNIT SIZE	COIL ROWS	FAN SPEED	EXTERNAL STATIC PRESSURE (in. wg)						
			0.00	0.05	0.10	0.15	0.20	0.25	0.30
02	3	High	240	195	150	105	—	—	—
		Med	210	165	120	—	—	—	—
		Low	185	140	—	—	—	—	—
	4	High	215	170	135	95	—	—	—
		Med	190	145	—	—	—	—	—
		Low	165	120	—	—	—	—	—
	5	High	190	145	110	—	—	—	—
		Med	180	130	—	—	—	—	—
		Low	160	115	—	—	—	—	—
03	3	High	295	260	220	185	155	—	—
		Med	250	215	175	—	—	—	—
		Low	205	170	—	—	—	—	—
	4	High	285	245	205	170	140	—	—
		Med	240	205	165	—	—	—	—
		Low	200	165	—	—	—	—	—
	5	High	260	220	180	—	—	—	—
		Med	230	195	—	—	—	—	—
		Low	195	160	—	—	—	—	—
04	3	High	410	370	335	310	290	—	—
		Med	295	255	220	—	—	—	—
		Low	225	185	150	—	—	—	—
	4	High	395	355	325	300	260	—	—
		Med	280	245	210	—	—	—	—
		Low	220	180	145	—	—	—	—
	5	High	380	335	305	280	245	—	—
		Med	270	235	210	—	—	—	—
		Low	215	175	—	—	—	—	—
06	3	High	620	565	515	475	440	—	—
		Med	460	405	355	315	—	—	—
		Low	310	255	205	—	—	—	—
	4	High	605	550	505	465	430	—	—
		Med	450	395	345	305	—	—	—
		Low	305	250	200	—	—	—	—
	5	High	590	535	485	440	410	—	—
		Med	440	385	335	—	—	—	—
		Low	300	245	—	—	—	—	—

NOTE: Air delivery is based on operation with dry coils and clean air filter.

Performance data (cont)



AIR DELIVERY (CFM) (cont) 42VA,VB,VF — 60 Hz MOTOR (cont)

42C,V Series Units

UNIT SIZE	COIL ROWS	FAN SPEED	EXTERNAL STATIC PRESSURE (in. wg)						
			0.00	0.05	0.10	0.15	0.20	0.25	0.30
08	3	High	700	640	600	545	500	—	—
		Med	575	515	475	420	—	—	—
		Low	360	300	260	—	—	—	—
	4	High	690	630	590	540	490	—	—
		Med	570	510	470	415	—	—	—
		Low	350	290	250	—	—	—	—
	5	High	680	620	580	530	480	—	—
		Med	560	500	460	—	—	—	—
		Low	340	280	—	—	—	—	—
10	3	High	915	850	780	725	655	—	—
		Med	675	650	580	530	—	—	—
		Low	490	445	395	345	—	—	—
	4	High	885	820	755	700	635	—	—
		Med	650	625	555	—	—	—	—
		Low	475	420	—	—	—	—	—
	5	High	860	790	720	640	560	—	—
		Med	625	600	520	—	—	—	—
		Low	465	410	—	—	—	—	—
12	3	High	1100	1025	970	920	865	—	—
		Med	935	860	805	755	700	—	—
		Low	580	525	500	420	—	—	—
	4	High	1070	995	945	895	840	—	—
		Med	910	835	780	730	655	—	—
		Low	565	510	485	405	—	—	—
	5	High	1040	965	915	865	810	—	—
		Med	890	820	765	715	640	—	—
		Low	545	490	465	385	—	—	—

NOTE: Air delivery is based on operation with dry coils and clean air filter.



AIR DELIVERY (CFM) (cont)
42VC,VE — 60 Hz MOTOR

UNIT SIZE	COIL ROWS	FAN SPEED	EXTERNAL STATIC PRESSURE (in. wg)						
			0.00	0.05	0.10	0.15	0.20	0.25	0.30
02	2	High	250	225	190	150	120	—	—
		Med	170	135	100	—	—	—	—
		Low	125	90	—	—	—	—	—
	3	High	230	210	180	145	115	—	—
		Med	155	120	—	—	—	—	—
		Low	115	—	—	—	—	—	—
	4	High	210	175	145	110	—	—	—
		Med	140	105	—	—	—	—	—
		Low	110	—	—	—	—	—	—
03	2	High	370	345	305	275	235	—	—
		Med	285	260	220	—	—	—	—
		Low	195	170	130	—	—	—	—
	3	High	345	315	285	255	230	—	—
		Med	265	245	205	—	—	—	—
		Low	185	160	—	—	—	—	—
	4	High	320	290	260	230	—	—	—
		Med	250	230	190	—	—	—	—
		Low	175	150	—	—	—	—	—
04	2	High	480	440	400	360	320	—	—
		Med	350	310	290	—	—	—	—
		Low	240	200	150	—	—	—	—
	3	High	460	420	385	345	310	—	—
		Med	335	295	275	—	—	—	—
		Low	230	190	140	—	—	—	—
	4	High	440	400	365	—	—	—	—
		Med	320	280	260	—	—	—	—
		Low	220	180	—	—	—	—	—
06	2	High	750	700	660	600	560	—	—
		Med	575	525	485	425	—	—	—
		Low	395	345	305	—	—	—	—
	3	High	670	625	580	540	495	—	—
		Med	510	460	425	—	—	—	—
		Low	355	305	265	—	—	—	—
	4	High	600	555	510	470	—	—	—
		Med	450	400	—	—	—	—	—
		Low	315	275	—	—	—	—	—

NOTE: Air delivery is based on operation with dry coils and clean air filter.

42C, V Series Units

Performance data (cont)



COOLING CAPACITY CORRECTION FACTORS

42C,V Series Units

ACTUAL AIRFLOW (Cfm)	UNIT SIZE													
	02		03		04		06		08		10		12	
	TH	SH	TH	SH	TH	SH	TH	SH	TH	SH	TH	SH	TH	SH
100	0.62	0.57	—	—	—	—	—	—	—	—	—	—	—	—
125	0.72	0.69	0.54	0.48	0.44	0.39	—	—	—	—	—	—	—	—
150	0.82	0.80	0.62	0.57	0.51	0.45	—	—	—	—	—	—	—	—
175	0.92	0.91	0.69	0.65	0.57	0.50	—	—	—	—	—	—	—	—
200	1.00	1.00	0.76	0.73	0.62	0.57	0.46	0.41	—	—	—	—	—	—
225	1.08	1.08	0.82	0.80	0.67	0.63	0.51	0.45	—	—	—	—	—	—
250	1.16	1.18	0.89	0.87	0.72	0.69	0.55	0.49	—	—	—	—	—	—
275	—	—	0.95	0.94	0.77	0.74	0.58	0.53	0.47	0.42	—	—	—	—
300	—	—	1.00	1.00	0.82	0.80	0.62	0.57	0.51	0.45	0.43	0.38	—	—
350	—	—	1.11	1.12	0.92	0.91	0.69	0.65	0.57	0.50	0.48	0.46	—	—
400	—	—	—	—	1.00	1.00	0.76	0.73	0.62	0.57	0.53	0.47	0.46	0.41
450	—	—	—	—	1.08	1.08	0.82	0.80	0.67	0.63	0.58	0.52	0.51	0.45
500	—	—	—	—	1.16	1.18	0.89	0.87	0.72	0.69	0.62	0.57	0.55	0.47
550	—	—	—	—	—	—	0.95	0.94	0.77	0.74	0.66	0.62	0.58	0.53
600	—	—	—	—	—	—	1.00	1.00	0.82	0.80	0.70	0.67	0.62	0.57
700	—	—	—	—	—	—	1.11	1.12	0.92	0.91	0.78	0.76	0.69	0.65
800	—	—	—	—	—	—	—	—	1.00	1.00	0.86	0.85	0.76	0.73
900	—	—	—	—	—	—	—	—	1.08	1.08	0.94	0.93	0.82	0.80
1000	—	—	—	—	—	—	—	—	1.16	1.18	1.00	1.00	0.89	0.87
1200	—	—	—	—	—	—	—	—	—	—	1.13	1.14	1.00	1.00
1400	—	—	—	—	—	—	—	—	—	—	—	—	1.11	1.12

LEGEND

SH — Sensible Heat
TH — Total Heat

NOTE: Use Sensible Heat correction factors when calculating heating capacity.

DIRECT-EXPANSION (DX) COIL COOLING CAPACITIES (MBtuh)* — MODELS 42CA,CE,CF,CG,CK

UNIT SIZE	SAT SUCT TEMP (F)	3 ROW								4 ROW							
		Entering Air (F) — db/wb															
		76/63		78/65		80/67		82/69		76/63		78/65		80/67		82/69	
		TH	SH	TH	SH	TH	SH	TH	SH	TH	SH	TH	SH	TH	SH	TH	SH
02	35	7.3	5.4	8.1	5.7	9.0	5.9	9.9	6.1	9.0	6.4	10.0	6.7	11.0	7.0	12.1	7.3
	40	5.7	4.7	6.6	4.9	7.4	5.2	8.3	5.4	7.3	5.6	8.3	5.9	9.3	6.2	10.3	6.5
	45	4.3	4.0	4.9	4.2	5.7	4.5	6.6	4.7	5.6	4.8	6.4	5.1	7.4	5.4	8.5	5.7
	50	3.1	3.1	3.6	3.5	4.1	3.8	4.5	4.0	4.1	4.0	4.7	4.3	5.5	4.6	6.4	4.9
03	35	10.5	7.8	11.6	8.1	12.8	8.4	14.0	8.7	12.7	9.1	14.0	9.5	15.3	9.8	16.6	10.2
	40	8.4	6.8	9.5	7.1	10.7	7.5	11.9	7.8	10.5	8.1	11.8	8.5	13.1	8.8	14.5	9.2
	45	6.3	5.8	7.3	6.2	8.5	6.5	9.7	6.8	8.1	7.0	9.3	7.4	10.7	7.8	12.1	8.1
	50	4.7	4.7	5.4	5.2	6.2	5.6	7.2	5.9	6.0	6.0	6.9	6.3	8.1	6.7	9.4	7.1
04	35	14.1	10.4	15.5	10.8	16.9	11.1	18.4	11.5	16.4	11.9	17.9	12.3	19.4	12.7	21.0	13.0
	40	11.6	9.2	13.0	9.6	14.5	10.0	16.0	10.4	13.8	10.7	15.4	11.1	17.0	11.5	18.6	11.9
	45	8.9	8.0	10.2	8.4	11.7	8.9	13.2	9.3	10.9	9.4	12.5	9.8	14.2	10.3	15.8	10.8
	50	6.6	6.6	7.6	7.2	8.8	7.7	10.2	8.1	8.2	8.0	9.4	8.5	11.0	9.0	12.7	9.5
06	35	19.0	14.5	21.0	15.0	23.1	15.6	25.3	16.1	23.3	17.1	25.6	17.7	27.9	18.3	30.3	18.9
	40	15.2	12.7	17.3	13.3	19.4	13.9	21.6	14.5	19.3	15.2	21.6	15.9	24.0	16.6	26.5	17.2
	45	11.6	11.0	13.3	11.6	15.2	12.2	17.4	12.8	15.0	13.3	17.1	14.0	19.6	14.7	22.1	15.3
	50	8.7	8.7	9.9	9.8	11.2	10.5	13.0	11.1	10.9	10.9	12.8	12.0	14.8	12.7	17.1	13.4
08	35	24.6	18.8	27.0	19.4	29.4	20.0	31.9	20.6	29.1	21.8	31.7	22.5	34.3	23.1	37.0	23.6
	40	20.1	16.8	22.6	17.5	25.2	18.2	27.8	18.9	24.6	19.7	27.4	20.5	30.1	21.2	33.0	21.8
	45	15.6	14.7	17.8	15.4	20.3	16.2	23.0	16.9	19.6	17.4	22.2	18.3	25.1	19.1	28.1	19.8
	50	11.9	11.9	13.4	13.2	15.3	14.0	17.6	14.8	14.6	14.6	17.0	15.9	19.5	16.8	22.4	17.6
10	35	29.9	23.3	32.7	24.0	35.6	24.7	38.5	25.3	35.2	26.9	38.3	27.6	41.3	28.2	44.4	28.8
	40	24.7	21.0	27.7	21.8	30.7	22.6	33.8	23.3	30.0	24.5	33.3	25.4	36.6	26.2	39.9	26.9
	45	19.3	18.4	22.0	19.3	24.9	20.2	28.1	21.0	24.1	21.8	27.3	22.8	30.7	23.7	34.3	24.6
	50	14.8	14.8	16.7	16.6	19.0	17.6	21.8	18.6	18.2	18.2	21.1	19.9	24.1	21.0	27.5	22.0
12	35	40.3	30.0	44.4	31.1	48.7	32.2	53.1	33.3	48.2	35.0	52.7	36.2	57.4	37.4	62.2	38.5
	40	32.7	26.4	36.9	27.7	41.2	28.9	45.7	30.0	40.2	31.2	44.9	32.6	49.8	33.9	54.7	35.1
	45	24.9	22.9	28.6	24.1	32.9	25.4	37.4	26.6	31.5	27.2	36.1	28.7	41.0	30.1	46.1	31.4
	50	18.6	18.6	21.2	20.6	24.4	21.9	28.4	23.1	23.5	23.1	26.9	24.7	31.3	26.1	36.3	27.5

LEGEND

db — Dry Bulb
SH — Sensible Heat
TH — Total Heat
wb — Wet Bulb

*Capacity based on R-22. Ratings at nominal cfm. All DX units to operate at high speed only.



**DIRECT-EXPANSION (DX) COIL COOLING CAPACITIES (MBtuh)* —
MODELS 42VA,VB,VF**

UNIT SIZE	SAT SUCT TEMP (F)	3 ROW								4 ROW							
		Entering Air (F) — db/wb															
		76/63		78/65		80/67		82/69		76/63		78/65		80/67		82/69	
		TH	SH	TH	SH	TH	SH	TH	SH	TH	SH	TH	SH	TH	SH	TH	SH
02	35	6.7	4.9	7.4	5.1	8.2	5.3	9.1	5.6	8.2	5.8	9.1	6.0	10.1	6.3	11.1	6.5
	40	5.3	4.2	6.0	4.4	6.8	4.7	7.6	4.9	6.7	5.0	7.5	5.3	8.4	5.5	9.4	5.8
	45	3.9	3.6	4.5	3.8	5.3	4.0	6.1	4.3	5.1	4.3	5.9	4.5	6.8	4.8	7.7	5.1
	50	2.8	2.8	3.3	3.2	3.8	3.4	4.5	3.6	3.7	3.6	4.3	3.8	5.0	4.1	5.9	4.3
03	35	9.7	7.1	10.7	7.4	11.8	7.7	12.9	8.0	11.6	8.2	12.8	8.6	14.0	8.9	15.3	9.2
	40	7.8	6.2	8.8	6.5	9.9	6.8	11.0	7.1	9.6	7.2	10.8	7.6	12.0	8.0	13.3	8.3
	45	5.8	5.3	6.7	5.6	7.8	5.9	8.9	6.2	7.4	6.2	8.5	6.6	9.8	7.0	11.0	7.3
	50	4.2	4.2	4.9	4.7	5.7	5.0	6.7	5.3	5.4	5.3	6.3	5.6	7.4	6.0	8.6	6.3
04	35	13.0	9.5	14.3	9.8	15.7	10.2	17.1	10.5	15.1	10.8	16.5	11.2	18.0	11.5	19.4	11.9
	40	10.7	8.4	12.0	8.8	13.4	9.1	14.8	9.5	12.7	9.6	14.2	10.0	15.7	10.5	17.2	10.8
	45	8.2	7.2	9.5	7.6	10.8	8.0	12.3	8.4	10.0	8.4	11.5	8.8	13.0	9.3	14.6	9.7
	50	6.0	6.0	6.9	6.5	8.1	6.9	9.5	7.3	7.4	7.2	8.6	7.6	10.1	8.1	11.7	8.5
06	35	17.5	13.1	19.5	13.7	21.4	14.2	23.4	14.7	21.4	15.5	23.6	16.1	25.7	16.6	28.0	17.2
	40	14.0	11.5	15.9	12.1	17.9	12.6	20.0	13.2	17.7	13.7	19.9	14.3	22.1	15.0	24.4	15.6
	45	10.6	9.9	12.2	10.5	14.1	11.0	16.1	11.6	13.7	11.9	15.7	12.5	18.0	13.2	20.3	13.8
	50	7.9	7.9	9.0	8.9	10.3	9.4	12.0	10.0	10.1	10.0	11.6	10.7	13.5	11.3	15.7	12.0
08	35	22.8	17.1	25.1	17.7	27.4	18.3	29.8	18.8	27.0	19.8	29.4	20.4	31.9	21.0	34.5	21.6
	40	18.6	15.2	21.0	15.9	23.4	16.5	25.8	17.1	22.7	17.8	25.3	18.5	27.9	19.2	30.6	19.8
	45	14.4	13.2	16.4	13.9	18.8	14.6	21.3	15.3	18.0	15.6	20.5	16.4	23.2	17.2	26.0	17.9
	50	10.7	10.7	12.3	11.9	14.1	12.7	16.3	13.3	13.5	13.3	15.5	14.2	17.9	15.0	20.7	15.8
10	35	28.0	21.3	30.7	22.0	33.4	22.7	36.2	23.3	32.9	24.5	35.8	25.2	38.8	25.9	41.7	26.5
	40	23.0	19.1	25.8	19.9	28.7	20.6	31.7	21.3	27.9	22.2	31.0	23.0	34.2	23.8	37.4	24.5
	45	17.9	16.6	20.4	17.5	23.3	18.3	26.3	19.2	22.3	19.6	25.3	20.5	28.6	21.4	32.0	22.3
	50	13.5	13.5	15.4	15.0	17.6	16.0	20.2	16.8	16.9	16.8	19.3	17.8	22.3	18.8	25.6	19.8
12	35	37.1	27.2	41.0	28.3	45.0	29.3	49.1	30.4	44.2	31.6	48.5	32.8	52.8	33.4	57.3	35.0
	40	30.1	23.9	34.0	25.1	38.0	26.2	42.2	27.3	36.8	28.0	41.2	29.3	45.7	30.6	50.3	31.8
	45	22.9	20.6	26.4	21.8	30.4	22.9	34.5	24.1	28.7	24.3	33.0	25.7	37.6	27.0	42.3	28.3
	50	16.8	16.8	19.4	18.5	22.5	19.7	26.3	20.8	21.2	20.7	24.5	22.0	28.6	23.3	33.3	24.7

42C,V Series Units

LEGEND

- db** — Dry Bulb
- SH** — Sensible Heat
- TH** — Total Heat
- wb** — Wet Bulb

*Capacity based on R-22. Ratings at nominal cfm. All DX units to operate at high speed only.

NOTE: DX coils are not available for 42VC,VE,VG units.

**DIRECT EXPANSION (DX) COIL AIRFLOW
CORRECTION FACTORS**

% OF NOMINAL AIRFLOW (Cfm)	CORRECTION FACTOR	
	Total	Sensible
80	0.95	0.93
90	0.97	0.96
100	1.00	1.00
110	1.02	1.04
120	1.05	1.08

NOTES:

1. Consult factory for values outside of table.
2. DX Total Capacity (MBtuh) =
Base TH x Total Correction Factor
- DX Sensible Capacity (MBtuh) =
Base SH x Sensible Correction Factor
- % of Nominal cfm =
 $\frac{\text{Actual cfm (from Air Delivery tables)}}{\text{Nominal cfm}}$

Performance data (cont)



HOT WATER HEATING CAPACITIES (MBtuh)* — MODELS 42CA,CE,CF,CG,CK,VA,VB,VF

42C,V Series Units

ROWS	UNIT SIZE	WATER FLOW (GPM)											
		0.5	1.0	1.5	2.0	3.0	4.0	5.0	6.0	7.0	8.0	10.0	12.0
1	02	7.6	8.8	9.2	9.4	9.6	9.8	—	—	—	—	—	—
	03	9.3	11.2	12.0	12.5	12.8	13.0	—	—	—	—	—	—
	04	12.0	14.0	15.3	16.2	16.8	17.1	—	—	—	—	—	—
	06	13.5	18.0	20.4	21.8	24.0	24.4	—	—	—	—	—	—
	08	—	21.3	24.8	26.5	28.8	30.0	—	—	—	—	—	—
	10	—	24.0	30.5	33.5	36.2	37.5	—	—	—	—	—	—
	12	—	26.5	35.8	38.8	42.3	44.0	—	—	—	—	—	—
2	02	12.1	14.1	15.0	15.7	16.4	16.8	—	—	—	—	—	—
	03	16.6	19.4	20.6	21.8	23.0	23.5	—	—	—	—	—	—
	04	18.5	23.4	25.5	26.7	28.6	29.4	—	—	—	—	—	—
	06	—	29.0	33.0	34.8	37.2	38.8	39.8	40.5	41.1	42.0	—	—
	08	—	32.8	37.7	40.8	45.0	46.9	47.5	49.7	50.6	51.4	—	—
	10	—	40.5	47.5	51.4	56.5	59.5	61.5	63.5	65.0	66.0	—	—
	12	—	49.0	55.5	59.5	64.7	68.0	70.7	72.7	74.0	75.3	—	—
3	02	15.0	17.4	18.6	19.4	20.3	20.8	—	—	—	—	—	—
	03	20.0	24.0	25.5	26.9	28.5	29.6	—	—	—	—	—	—
	04	22.5	29.0	31.6	33.0	35.2	36.4	—	—	—	—	—	—
	06	—	—	40.5	43.0	46.0	47.8	49.0	50.0	50.6	51.1	—	—
	08	—	—	47.0	51.2	55.5	58.0	60.0	61.5	62.6	63.5	—	—
	10	—	—	—	63.5	69.5	73.5	76.0	78.4	80.0	81.5	82.8	84.5
	12	—	—	—	70.0	79.4	84.2	87.5	90.0	92.0	93.4	96.0	—
4	02	17.2	20.0	21.2	21.8	22.5	23.0	—	—	—	—	—	—
	03	21.5	27.0	29.1	30.0	31.8	32.6	—	—	—	—	—	—
	04	25.0	33.0	35.6	37.0	38.5	39.6	—	—	—	—	—	—
	06	—	—	46.0	50.0	53.5	55.0	56.0	57.0	57.8	58.7	—	—
	08	—	—	51.3	55.0	60.0	63.0	65.0	67.4	68.3	—	—	—
	10	—	—	—	70.5	77.7	81.5	84.1	86.3	88.0	89.5	91.3	92.5
	12	—	—	—	82.5	92.5	97.5	101.1	104.0	106.5	108.5	110.5	112.0

NOTE: Ratings based on nominal cfm, 70 F edb, 180 F ewb.

HOT WATER HEATING CAPACITIES (MBtuh) — MODELS 42VC,VE

ROWS	UNIT SIZE	WATER FLOW (GPM)						
		0.5	1.0	1.5	2.0	2.5	3.0	4.0
1	02	7.2	9.7	10.4	10.7	10.8	—	—
	03	9.5	12.4	14.1	15.1	15.5	—	—
	04	10.1	14.5	17.4	19.4	20.8	21.5	22.2
	06	14.6	20.2	23.5	26.0	27.5	28.7	29.7
2	02	11.2	14.3	15.6	16.5	17.2	17.7	—
	03	14.3	19.1	21.8	23.4	24.3	24.6	—
	04	—	22.6	27.1	30.0	32.0	33.2	34.1
	06	—	31.1	36.6	39.7	42.0	44.1	46.8
3	02	12.8	16.5	18.4	19.7	20.7	21.4	—
	03	18.0	22.8	25.9	27.7	28.8	29.4	—
	04	—	25.5	31.8	33.6	35.2	36.2	36.8
	06	—	37.0	40.9	43.7	46.0	47.8	51.0

NOTE: Ratings based on nominal airflow (cfm), 70 F edb, 180 F ewb.



COOLING AND HEATING CAPACITIES (Btuh) — MODEL 42VG

UNIT SIZE	AIRFLOW (Cfm)	WATER FLOW (Gpm)	PRESSURE DROP (ft. wg)	COOLING			HEATING	
				Entering Water Temperature (F)				
				40	45	50	160	180
01	150	1.0	0.8	4,240	3,450	2,750	8,200	10,000
		1.5	1.6	4,950	4,080	3,270	8,750	10,850
		2.0	2.7	5,320	4,500	3,500	9,220	11,300
		2.5	3.6	5,500	4,620	3,620	9,450	11,700
		3.0	5.5	5,590	4,850	3,770	9,700	12,300
03	300	1.0	1.5	7,850	6,400	5,100	15,500	18,900
		1.5	2.9	8,850	7,800	6,250	16,700	20,400
		2.0	4.8	10,200	8,660	6,730	17,300	21,100
		2.5	6.4	10,800	9,100	7,130	17,600	21,500
		3.0	9.7	11,100	9,650	7,500	18,000	22,000

NOTE: Cooling capacity based on standard conditions at 80 F db, 67 F wb entering air temperature. To determine sensible, use ratio of 0.83 to above total.

HOT WATER CAPACITY CORRECTION FACTORS

ENTERING AIR TEMP. (F)	ENTERING WATER TEMPERATURE (F)										
	100	110	120	130	140	150	160	170	180	190	200
50	0.455	0.545	0.636	0.727	0.818	0.909	1.000	1.091	1.182	1.273	1.364
55	0.409	0.500	0.591	0.682	0.773	0.864	0.955	1.045	1.136	1.227	1.318
60	0.363	0.455	0.545	0.636	0.727	0.818	0.909	1.000	1.091	1.182	1.273
65	0.318	0.409	0.500	0.591	0.682	0.773	0.864	0.955	1.045	1.136	1.227
70	0.272	0.363	0.455	0.545	0.636	0.727	0.818	0.909	1.000	1.091	1.182
75	0.227	0.318	0.409	0.500	0.591	0.682	0.773	0.864	0.955	1.045	1.136
80	0.182	0.272	0.363	0.455	0.545	0.636	0.727	0.818	0.909	1.000	1.091

NOTE: Hot Water Capacity (MBtuh) = Base Capacity x Hot Water Capacity Correction Factor x SH (SH value found in Cooling Capacity Correction Factors table on page 60).

**STEAM HEATING CAPACITIES (Btuh)
MODELS 42VA,VB,VF,CA,CE,CF,CG,CK**

UNIT SIZE	1-ROW COIL	2-ROW COIL
02	12,270	19,920
03	16,890	28,580
04	21,940	37,530
06	31,610	54,995
08	40,415	71,250
10	52,685	91,655
12	62,355	109,120

NOTES:

1. Ratings based on nominal cfm, 70 F edb, 2 psig.
2. All capacities above 50,000 Btuh rating are beyond the capacity of the standard control valve. Consult factory for these applications.
3. Steam coils are not available for 42VC,VE,VG units.

HOT WATER AND CHILLED WATER COIL Cv FACTORS

UNIT	SIZE	1-ROW	2-ROW	3-ROW	4-ROW
42CA, 42CE, 42CK, 42CG, 42CF, 42VA, 42VB, 42VF	02	2.1	1.4	1.1	1.0
	03	1.9	1.3	1.0	0.9
	04	1.8	1.2	0.9	0.9
	06	1.5	2.8	2.4	2.0
	08	1.4	2.6	2.2	1.9
	10	1.3	2.4	3.3	3.1
	12	1.2	2.2	3.2	3.0
42VC, 42VE	02	1.8	1.2	1.0	—
	03	1.6	1.1	1.0	—
	04	1.5	1.0	2.0	—
	06	1.3	2.3	1.9	—

42C, V Series Units

ELECTRIC HEATER DATA

HEATER VOLTAGE	HEATER kW								
	0.5	1.0	1.5	2.0	3.0	4.0	5.0	6.0	8.0
	FLA								
120	4.2	8.3	12.5	16.7	25.0	—	—	—	—
208	2.4	4.8	7.2	9.6	14.4	19.2	24.0	28.8	38.5
240	2.1	4.2	6.3	8.3	12.5	16.7	20.8	25.0	33.3
277	1.8	3.6	5.4	7.2	10.8	14.4	18.05	21.7	28.9

LEGEND

FLA — Full Load Amps

NOTE: All heaters are single-stage and single-phase.

UL Listing

The UL Listing signifies that Carrier's fan coil units have been examined by UL and comply with the organization's applicable standards. The Canadian Standards Association (CSA) and Underwriters' Laboratories of Canada also approve the fan coil units.



42CA,CE,CG AND CK MOTOR DATA

VOLTS/PH-Hz	FAN SPEED	FAN SPEED (RPM)	UNIT SIZE											
			02			03			04			06		
			Nominal Hp	Watts	Amps	Nominal Hp	Watts	Amps	Nominal Hp	Watts	Amps	Nominal Hp	Watts	Amps
115-1-60	H	1200	1/30	50	0.53	1/30	85	0.83	1/12	165	1.25	1/12	165	1.25
	M	980		35	0.31		55	0.50		80	0.70		80	0.72
	L	790		28	0.27		35	0.34		50	0.45		50	0.45
208-1-60	H	1200	1/30	86	0.45	1/30	89	0.46	1/12	115	0.64	1/12	130	0.64
	M	980		60	0.29		60	0.29		89	0.43		100	0.47
	L	790		28	0.15		28	0.15		45	0.22		48	0.24
230-1-60	H	1200	1/30	103	0.45	1/30	106	0.40	1/12	135	0.64	1/12	155	0.64
	M	980		70	0.31		73	0.32		105	0.45		115	0.52
	L	790		33	0.15		33	0.15		53	0.24		60	0.28
277-1-60	H	1200	1/30	80	0.33	1/30	80	0.34	1/15	150	0.64	1/15	155	0.64
	M	980		64	0.26		66	0.26		116	0.43		110	0.43
	L	790		40	0.16		43	0.16		60	0.25		90	0.35
220-1-50	H	1100	1/30	87	0.42	1/30	87	0.42	1/12	118	0.56	1/12	150	0.69
	M	850		62	0.29		62	0.29		93	0.44		112	0.52
	L	350		40	0.19		43	0.19		52	0.25		56	0.26

NOTE: Motor nameplate amps may vary.

VOLTS-PH-Hz	FAN SPEED	FAN SPEED (RPM)	UNIT SIZE								
			08			10*			12*		
			Nominal Hp	Watts	Amps	Nominal Hp	Watts	Amps	Nominal Hp	Watts	Amps
115-1-60	H	1200	1/6	235	2.10	1/12 (2)	305	2.70	1/6 (2)	435	4.00
	M	980		160	1.50		150	1.40		305	2.80
	L	790		120	1.20		100	0.90		130	1.20
208-1-60	H	1200	1/6	195	1.00	1/12 (2)	260	1.25	1/6 (2)	340	2.00
	M	980		135	0.69		190	0.94		255	1.33
	L	790		90	0.47		90	0.46		180	0.94
230-1-60	H	1200	1/6	210	1.00	1/12 (2)	290	1.25	1/6 (2)	380	2.00
	M	980		150	0.70		220	1.00		285	1.34
	L	790		105	0.50		110	0.50		210	1.00
277-1-60	H	1200	1/8	240	0.92	1/15 (2)	270	1.25	1/8 (2)	440	1.84
	M	980		160	0.62		200	0.80		300	1.20
	L	790		90	0.35		75	0.25		175	0.66
220-1-50	H	1100	1/6	152	0.80	1/12 (2)	248	1.18	1/6 (2)	280	1.55
	M	850		105	0.52		192	0.91		200	0.99
	L	350		75	0.38		105	0.50		140	0.68

*Total motor amps and watts shown for units with 2 motors.

NOTE: Motor nameplate amps may vary.



42CF MOTOR DATA

VOLTS-PH-Hz	FAN SPEED	FAN SPEED (RPM)	UNIT SIZE											
			04			06			08			10*		
			Nominal Hp	Watts	Amps	Nominal Hp	Watts	Amps	Nominal Hp	Watts	Amps	Nominal Hp	Watts	Amps
115-1-60	H	1200	1/8	150	1.40	1/8	180	0.83	1/8	225	1.70	1/8 (2)	300	2.80
	M	980		160	1.65		175	1.70		195	1.70		345	3.37
	L	790		135	1.45		140	1.65		165	1.45		290	2.95
208-1-60	H	1200	1/8	135	0.68	1/8	150	1.45	1/8	160	0.74	1/8 (2)	280	1.44
	M	980		120	0.60		130	0.72		135	0.67		250	1.25
	L	790		105	0.54		110	0.66		110	0.57		205	1.05
230-1-60	H	1200	1/8	150	0.68	1/8	160	0.57	1/8	170	0.75	1/8 (2)	300	1.44
	M	980		128	0.58		145	0.72		135	0.67		260	1.30
	L	790		115	0.55		127	0.66		127	0.57		205	1.05
277-1-60	H	1200	1/8	145	0.60	1/8	155	0.60	1/8	170	0.66	1/8 (2)	310	1.20
	M	980		125	0.45		130	0.60		145	0.54		265	0.95
	L	790		90	0.36		90	0.48		100	0.39		195	0.74
220-1-50	H	1200	1/6	205	1.00	1/6	225	0.36	1/6	256	1.20	1/6 (2)	420	2.00
	M	980		145	0.69		150	1.08		160	0.76		285	1.36
	L	790		93	0.45		95	0.47		95	0.48		180	0.88

*Total motor amps and watts shown for units with 2 motors.
NOTE: Motor nameplate amps may vary.

42VA,VB, AND VF MOTOR DATA

VOLTS-PH-Hz	FAN SPEED	FAN SPEED (RPM)	UNIT SIZE											
			02			03			04			06		
			Nominal Hp	Watts	Amps	Nominal Hp	Watts	Amps	Nominal Hp	Watts	Amps	Nominal Hp	Watts	Amps
115-1-60	H	1200	1/30	50	0.53	1/30	80	0.83	1/12	130	1.25	1/6	180	2.00
	M	980		35	0.31		50	0.48		75	0.70		140	1.30
	L	790		28	0.27		35	0.33		50	0.47		60	0.57
208-1-60	H	1200	1/30	85	0.45	1/30	85	0.46	1/12	110	0.64	1/6	190	1.00
	M	980		60	0.29		60	0.29		85	0.40		130	0.59
	L	790		28	0.14		28	0.14		45	0.22		90	0.47
230-1-60	H	1200	1/30	100	0.45	1/30	102	0.46	1/12	120	0.64	1/6	205	1.00
	M	980		70	0.31		70	0.31		100	0.43		150	0.71
	L	790		33	0.15		33	0.15		53	0.24		105	0.50
277-1-60	H	1200	1/30	80	0.33	1/30	82	0.34	1/15	140	0.63	1/6	205	0.92
	M	980		65	0.26		67	0.26		110	0.44		140	0.57
	L	790		40	0.16		43	0.17		65	0.25		80	0.34
220-1-50	H	1200	1/30	80	0.40	1/30	85	0.40	1/12	145	0.70	1/6	175	0.91
	M	980		60	0.27		60	0.27		140	0.56		155	0.62
	L	790		30	0.15		30	0.15		120	0.38		130	0.43

VOLTS-PH-Hz	FAN SPEED	FAN SPEED (RPM)	UNIT SIZE								
			08			10*			12*		
			Nominal Hp	Watts	Amps	Nominal Hp	Watts	Amps	Nominal Hp	Watts	Amps
115-1-60	H	1200	1/6	210	2.10	1/12 (2)	240	2.20	1/6 (2)	370	4.00
	M	980		140	1.30		145	1.30		265	2.50
	L	790		65	0.61		100	0.40		125	1.25
208-1-60	H	1200	1/6	195	1.00	1/12 (2)	210	1.20	1/6 (2)	340	2.00
	M	980		135	0.69		160	0.80		220	1.15
	L	790		90	0.47		90	0.45		170	0.84
230-1-60	H	1200	1/6	215	1.00	1/12 (2)	235	1.20	1/6 (2)	370	2.00
	M	980		155	0.71		190	0.85		285	1.40
	L	790		110	0.50		115	0.50		200	1.00
277-1-60	H	1200	1/6	210	0.92	1/12 (2)	270	1.26	1/6 (2)	370	1.84
	M	980		140	0.58		200	0.82		255	1.10
	L	790		85	0.35		125	0.45		145	0.65
220-1-50	H	1200	1/6	185	0.92	1/12 (2)	230	1.30	1/6 (2)	265	1.73
	M	980		160	0.63		190	1.02		190	1.00
	L	790		135	0.44		155	0.60		135	0.80

*Total motor amps and watts shown for units with 2 motors.
NOTE: Motor nameplate amps may vary.

42C, V Series Units

Electrical data (cont)



42VC,VE MOTOR DATA

42C,V Series Units

VOLTS-PH-Hz	FAN SPEED	FAN SPEED (RPM)	UNIT SIZE								
			02			03			04		
			Nominal Hp	Watts	Amps	Nominal Hp	Watts	Amps	Nominal Hp	Watts	Amps
115-1-60	H	1200	1/20	68	0.34	1/12	135	1.35	1/12	150	1.45
	M	980		45	0.30		65	0.60		65	0.60
	L	790		25	0.20		40	0.30		40	0.30
208-1-60	H	1200	1/20	56	0.46	1/12	109	0.56	1/12	116	0.60
	L	790		35	0.20		55	0.30		58	0.30
230-1-60	H	1200	1/20	64	0.50	1/12	128	0.60	1/12	138	0.64
	L	790		42	0.22		65	0.28		67	0.30
277-1-60	H	1200	1/20	85	0.35	1/12	135	0.58	1/12	140	0.58
	M	980		45	0.12		85	0.33		88	0.34
	L	790		35	0.07		55	0.22		57	0.22

VOLTS-PH-Hz	FAN SPEED	FAN SPEED	UNIT SIZE		
			06*		
			Nominal Hp	Watts	Amps
115-1-60	H	1200	1/12 (2)	260	2.70
	M	980		125	1.20
	L	790		85	0.80
208-1-60	H	1200	1/12 (2)	205	1.00
	L	790		103	0.50
230-1-60	H	1200	1/12 (2)	245	1.10
	L	790		120	0.52
277-1-60	H	1200	1/12 (2)	260	1.16
	M	980		155	0.65
	L	790		100	0.40

NOTE: Motor nameplate amps may vary.

42VG MOTOR DATA

VOLTS-PH-Hz	FAN SPEED	FAN SPEED (RPM)	UNIT SIZE					
			01			03*		
			Nominal Hp	Watts	Amps	Nominal Hp	Watts	Amps
115-1-60	H	1200	1/20	120	1.56	1/20 (2)	235	3.10
	M	980		75	0.92		145	1.80
	L	790		145	0.78		120	1.54

*Total motor amps and watts shown for units with 2 motors.

NOTE: Motor nameplate amps may vary.

Model number nomenclature



42D Series Units

42D A A 06 B R C - 5 - - - -

42D Series – Ducted Fan Coil Unit

Model

- A – Furred-in ceiling model
- C – Furred-in ceiling model with plenum
- D – Vertical model with galvanized full casing
- E – Ceiling model with galvanized full casing
- F – Exposed-ceiling cabinet model

Design Series - A

Size - Cfm

- 06 – 600
- 08 – 800
- 10 – 1000
- 12 – 1200
- 14 – 1400
- 16 – 1600
- 18 – 1800
- 20 – 2000

Coil

- B – 4 Row Standard
- G – 4/1 Opposite
- H – 4/1 Same
- J – 4/2 Opposite
- K – 4/2 Same
- L – 6 Row High Capacity
- M – 6/1 Opposite
- N – 6/1 Same

Arrangement

42DA, DC, DE, DF		42DD	
Return	Supply	Return	Supply
5 – Bottom	Front	Front	Top
6 – Rear	Front	Bottom	Top

Electric Heaters

Motor

- C – 120V PSC-STD
- D – 208/1/60 PSC
- E – 230/1/60/PSC
- F – 277/1/60 PSC

Hand

- R – Right
- L – Left

ARI capacity ratings

The 42D series fan coil units are certified in compliance with the Air Conditioning and Refrigeration Institute (ARI) Industry Standard 440-98 for room fan coil units. Approved standard ratings are tabulated below:



ARI APPROVED STANDARD RATINGS*

UNIT TYPE	UNIT SIZE†	NOMINAL CFM	GPM	COOLING CAPACITY		POWER INPUT (WATTS)**
				Total Heat Btuh	Sensible Heat Btuh	
42DF	06	600	3.7	18,100	13,700	225
	08	800	5.0	23,400	17,600	275
	10	1000	6.9	33,300	24,000	400
	12	1200	8.7	41,800	30,200	450
	14	1400	10.0	48,900	34,000	470

*Ratings based on motor at high fan speed, standard air and dry coil operation, 10 degrees F water temperature rise; entering air temperatures of 80 F db, 67 F wb; entering water temperature 45 F.

†With standard 4-row coil.

**Motor type, permanent split capacitor, operating at 115-1-60 voltage.



SOUND POWER DATA 42D SOUND RATINGS — OCTAVE BAND SOUND POWER LEVEL RATINGS* (dB)

SIZE	NOMINAL CFM	SPEED	RPM	CENTER FREQUENCY — Hz						
				125	250	500	1000	2000	4000	8000
06	600	High	820	71	68.5	57	55.5	46	42.5	34.5
		Medium	660	64.5	60.5	51.5	48.5	40.5	35.5	—
		Low	560	55	50.5	42	37	27	—	—
08	800	High	1000	68.5	66	58	56	46.5	41	30
		Medium	820	64.5	61.5	52	46	41	32	—
		Low	595	58	51.5	45.5	40	29	—	—
10	1000	High	1070	67.5	62.5	57	55	47	40	29.5
		Medium	875	61.5	57	51.5	46.5	39.5	31.5	—
		Low	690	52.5	49.5	44	39	29.5	18	—
12	1200	High	890	68.5	66	57	50.5	44.5	39.5	29
		Medium	690	65	62.5	52	46.5	40	32.5	—
		Low	580	61	58.5	49.5	43	36	28	—
14	1400	High	1000	69	66	58	54	46	40.5	29
		Medium	750	66	62	53.5	47.5	42	33	—
		Low	475	60	56.5	50	43	36.5	28	—
16	1600	High	1100	70	65.5	59.5	57	48	43.5	34.5
		Medium	750	66	61	55.5	50	43.5	38	27.5
		Low	475	61	55	50	42.5	35.5	27	19
18	1800	High	1060	70	65	60	57.5	49	44	34
		Medium	885	65.5	59.5	55	49.5	44	38.5	26
		Low	680	58	53	49	42	36	26.5	—
20	2000	High	1030	71.5	64.5	60.5	58	51.5	47	37
		Medium	850	65	59	55	49.5	44.5	38.5	26
		Low	650	57.5	51.5	48.5	42	35	26	—

*Testing per Proposed Standard Ducted Units, ARI Standard 260 (ANSI SI.32-1980). The sound data represents radiated sound power.

42D Series Units

Physical data and dimensions

UNIT SIZE 42D	06	08	10	12	14	16	18	20
NOMINAL AIRFLOW (cfm)	600	800	1000	1200	1400	1600	1800	2000
SHIPPING WEIGHT (lb)*								
42DA	64	79	93	110	119	129	137	155
42DC	94	107	150	169	174	178	195	220
42DD	150	163	176	195	220	235	240	247
42DE	135	155	165	184	199	215	232	243
42DF	157	167	177	199	215	229	249	258
COIL WATER WEIGHT (Approx lb per row of coil) 42D Series	1.3	1.6	1.9	2.3	2.7	3.0	3.4	3.7
COILS FPI Coil Face Area (sq. ft)	1.6	2.1	2.5	3.0	3.5	4.1	4.6	5.0
MOTOR (qty) 42D Series	1	1	1	2	2	2	2	2
BLOWER (qty) 42D Series	1	1	1	2	2	2	2	2
FILTERS Nominal Size (in.) (1-in. thick)								
42DA					NA			
42DC	14 x 21	14 x 26	14 x 30	14 x 35	14 x 40	14 x 45	14 x 50	14 x 54
42DD	13 x 21	13 x 26	13 x 30	13 x 35	13 x 40	13 x 45	13 x 50	13 x 54
42DE	14 x 14 ³ / ₄	14 x 19 ³ / ₄	14 x 23 ³ / ₄	14 x 28 ³ / ₄	14 x 33 ³ / ₄	14 x 38 ³ / ₄	14 x 43 ³ / ₄	14 x 47 ³ / ₄
42DF	14 x 14 ³ / ₄	14 x 20	14 x 24	14 x 28 ³ / ₄	14 x 34	14 x 38	14 x 44	14 x 48
Qty								
SUPPLY DUCT COLLAR	1-in.							
PIPING CONNECTIONS (Sweat - 4-Row) Inlet (in. OD) Outlet (in. OD)	5/8		7/8		1 1/8		1 1/8	

*Calculate Operating Weight of unit: Shipping Weight + Coil Water Weight x Number of Coil Rows.

Physical data and dimensions (cont)



42DA FURRED-IN CEILING MODEL

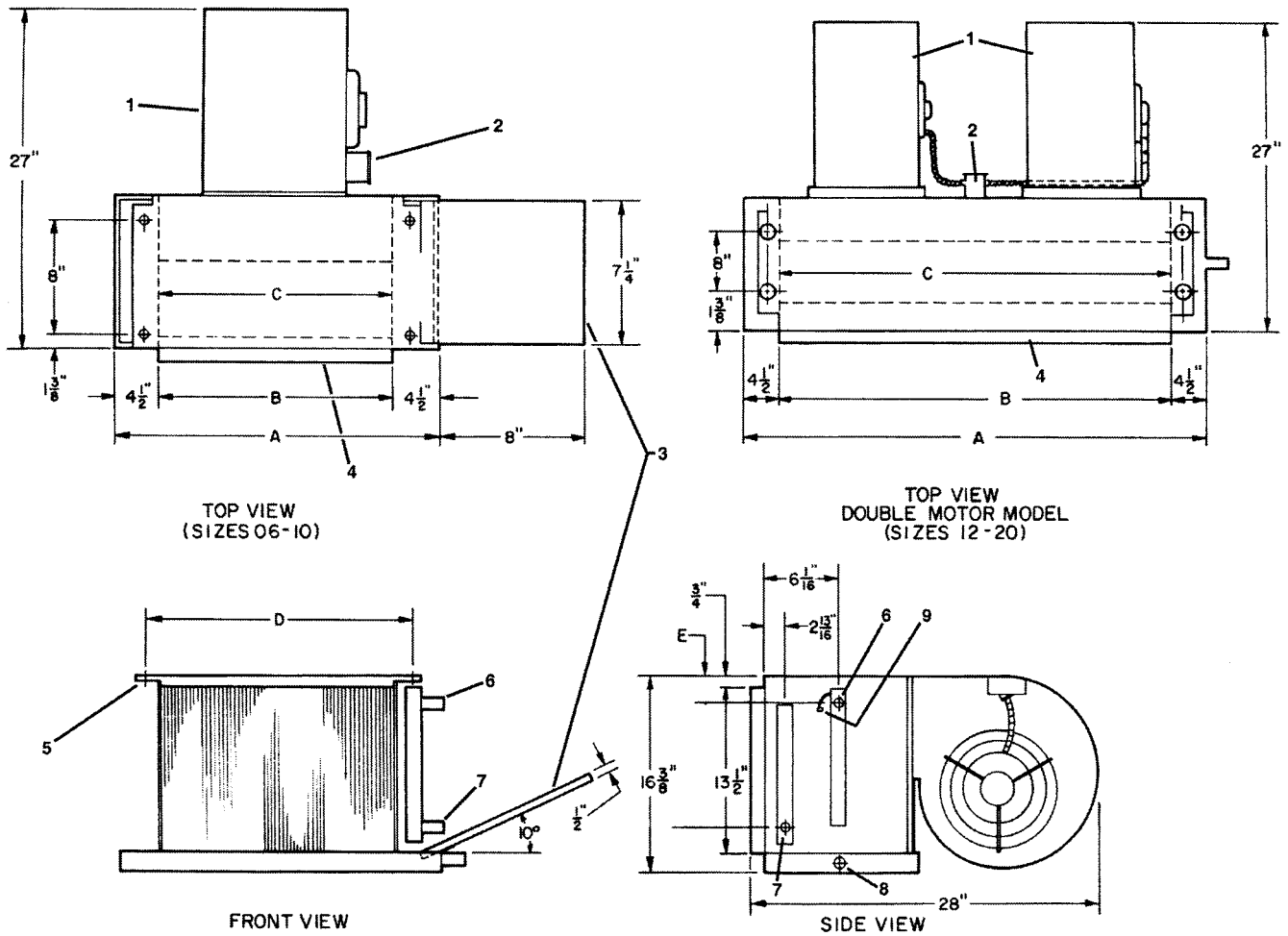

UNIT SIZE	NOM CFM	DIMENSIONS (in. $\pm 1/8$)				
		A	B	C	D	E
06	600	23	14	15	17	3 ⁵ / ₈
08	800	28	19	20	22	3 ⁵ / ₈
10	1000	32	23	24	26	3 ⁵ / ₈
12	1200	37	28	29	31	3 ⁵ / ₈
14	1400	42	33	34	36	3 ¹ / ₁₆
16	1600	47	38	39	41	3 ¹ / ₁₆
18	1800	52	43	44	46	3 ¹ / ₁₆
20	2000	56	47	48	50	3 ¹ / ₁₆

- LEGEND
- 1 — Motor-Blower Assembly
 - 2 — Motor Junction Box
 - 3 — Auxiliary Drip Lip (Optional, Shipped Loose)
 - 4 — Supply Duct Collar, 1 inch
 - 5 — Mounting Holes (four, 3/4-in. diameter) have Rubber Grommets with 3/8-in. holes.
 - 6 — Return Connection
 - 7 — Supply Connection
 - 8 — Drain Connection, 7/8-in. OD
 - 9 — Air Vent, 1/8-in. MPT

NOTES:

1. R.H. unit shown; L.H. unit opposite. Coil connection locations are $\pm 5/8$ inches.
2. Sizes 06, 08 and 10 have one motor, one blower; sizes 12 through 20 have 2 motors, 2 blowers.
3. Standard 4-row coil shown. Other coil option dimensional data available on request.
4. See 42DA-203-1 for optional coil connections.
5. Fan switch, wall plate not shown.
6. Galvanized finish provided as standard.

42D Series Units

Physical data and dimensions (cont)



42DC FURRED-IN CEILING MODEL WITH PLENUM

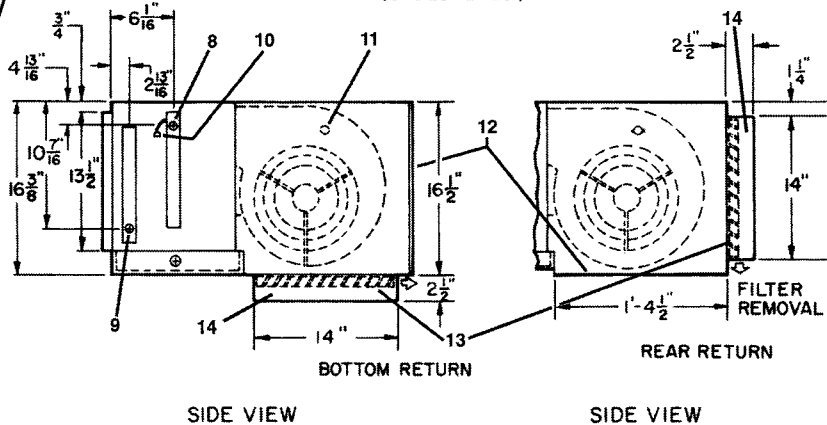
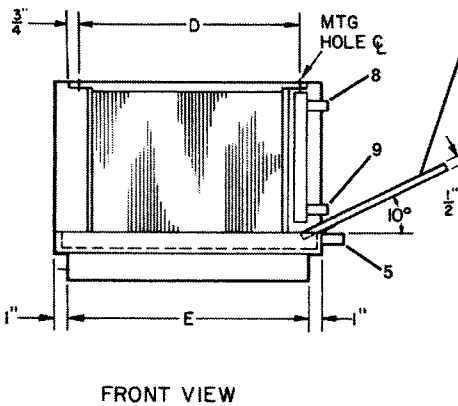
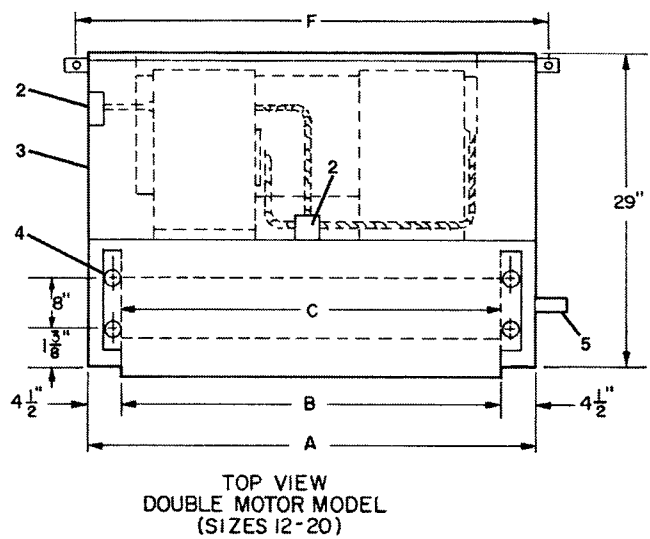
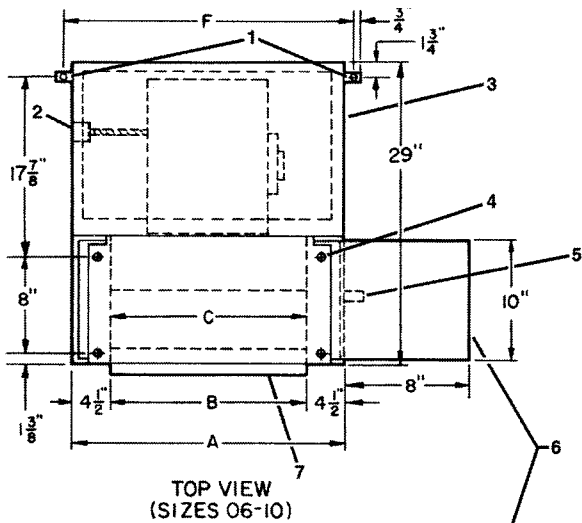

REAR RETURN

42D Series Units

UNIT SIZE	NOM CFM	DIMENSIONS (in. ± 1/8)					
		A	B	C	D	E	F
06	600	23	14	15	17	21	25 1/4
08	800	28	19	20	22	26	30 1/4
10	1000	32	23	24	26	30	34 1/4
12	1200	37	28	29	31	35	39 1/4
14	1400	42	33	34	36	40	44 1/4
16	1600	47	38	39	41	45	49 1/4
18	1800	52	43	44	46	50	54 1/4
20	2000	56	47	48	50	54	58 1/4

LEGEND

- 1 — Mounting Clips (Shipped Loose)
- 2 — Motor Junction Box Opposite Piping
- 3 — Insulated Return Air Plenum
- 4 — Mounting Holes (four, 3/4-in. diameter) with rubber grommet
- 5 — Drain Connection, 7/8-in. OD
- 6 — Auxiliary Drip Lip (Shipped Loose with 3/8-in. Hole)
- 7 — Supply Duct Collar, 1 inch
- 8 — Return Connection
- 9 — Supply Connection
- 10 — Air Vent, 1/8-in. MPT
- 11 — Electrical Connection KO
- 12 — Access Panel
- 13 — Filter, 1-in.
- 14 — Return Duct Collar, 2 1/2 inches

NOTES:

1. R.H. unit shown; L.H. unit opposite. Coil connection locations are ± 5/8 inches.
2. Sizes 06, 08 and 10 have one motor, one blower. Sizes 12 through 20 have 2 motors, 2 blowers.
3. Filter and filter rack are standard.
4. Standard 4-row coil shown. Other coil option dimensional data available on request.
4. See 42DA-203-1 for optional coil connections.
5. Fan switch, wall plate not shown.
6. Galvanized finish provided as standard.

42DD VERTICAL MODEL WITH FULL CASING

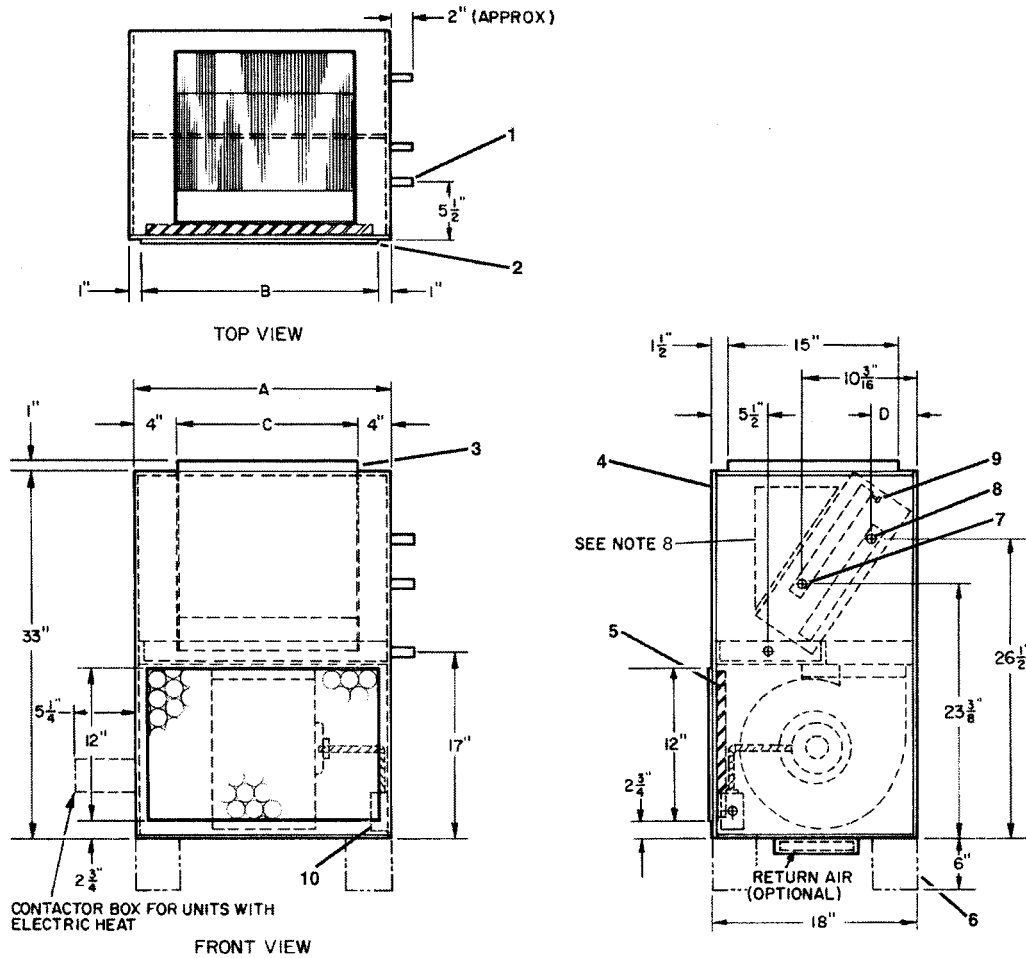

UNIT SIZE	NOM CFM	DIMENSIONS (in. $\pm 1/8$)			
		A	B	C	D
06	600	23	21	15	6 $\frac{11}{16}$
08	800	28	26	20	6 $\frac{11}{16}$
10	1000	32	30	24	5 $\frac{3}{8}$
12	1200	37	35	29	5 $\frac{3}{8}$
14	1400	42	40	34	5 $\frac{3}{8}$
16	1600	47	45	39	5 $\frac{3}{8}$
18	1800	52	50	44	5 $\frac{3}{8}$
20	2000	56	54	48	5 $\frac{3}{8}$

NOTES:

1. R.H. unit shown; L.H. unit opposite. Coil connection locations are $\pm 5/8$ inches.
2. Standard 4-row coil shown. Other coil option dimensional data available on request.
3. Sizes 06, 08 and 10 have one motor, one blower. Sizes 12 through 20 have 2 motors, 2 blowers.
4. Supply and return connections terminate within unit when valves are factory installed.
5. See 42DD-203-1 for optional coil connections.
6. Fan switch, wall plate not shown.
7. Galvanized finish provided as standard.
8. Units with internal factory valve packages have external connections located in triangular section above coil.
9. For bottom return (required for optional slide-in filter service from front) use dimension B minus 3 in.
10. Consult Carrier for ducted front return air and external filter rack with 1-in. duct collar and throwaway filters.
11. Units with electric heat require additional access on the side of unit for servicing contactor box.

42D Series Units

Physical data and dimensions (cont)



42DE CEILING MODEL WITH FULL CASING

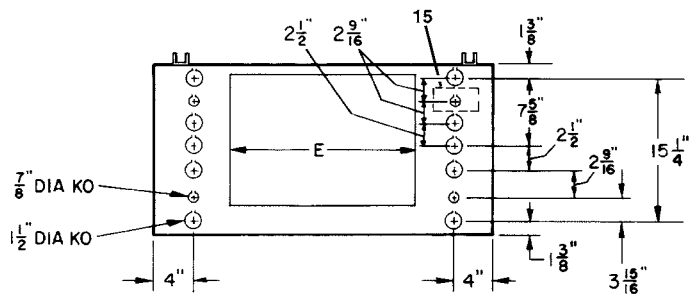
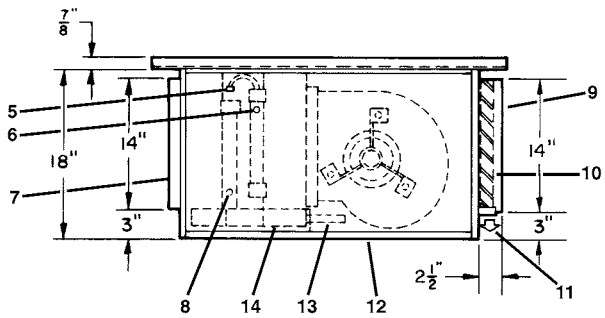
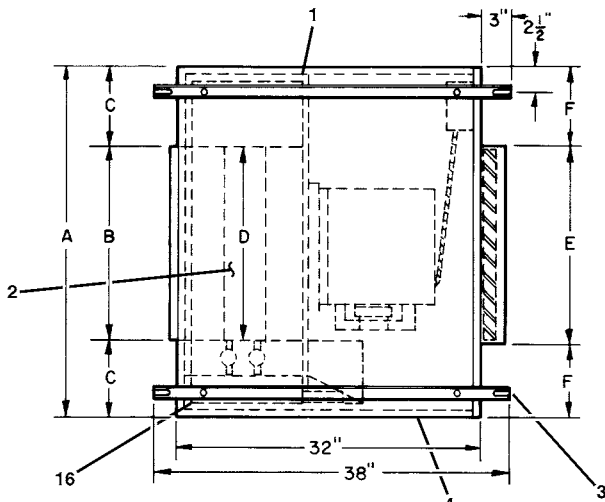

RIGHT SIDE VIEW

REAR PANEL ELEVATION

42D Series Units

UNIT SIZE	NOM CFM	DIMENSIONS (in. ± 1/8)					
		A	B	C	D	E	F
06	600	31	15	8	15	15	8
08	800	36	20	8	20	20	8
10	1000	40	24	8	24	24	8
12	1200	45	29	8	29	29	8
14	1400	50	34	8	34	34	8
16	1600	55	39	8	39	39	8
18	1800	60	44	8	44	44	8
20	2000	64	48	8	48	48	8

NOTES:

- R.H. unit shown; L.H. unit opposite.
- Coil stub-out location data available on request.
- Unit fabricated of galvanized steel.
- Internal parts fabricated of galvanized steel.
- Sizes 06, 08 and 10 have one motor, one blower. Sizes 12 through 20 have 2 motors, 2 blowers.
- Units must have drain line pitched and trapped externally.
- See 42DA-203-1 for optional coil connections.
- Fan switch, wall plate not shown.
- Galvanized finished provided as standard.

LEGEND

- Insulation, 1/2-in. Thick Fiberglass
- Coil, 4-row
- Unit Mounting Channel (2), 14-gage; 4 Mounting Slots, 1/2-in. x 2-in.
- Side Access Panels
- Manual Air Vent
- Coil Outlet (See Table)
Copper Sweat Connection
- Supply Air Duct Connection, 1 inch
- Coil Inlet (See Table),
Copper Sweat Connection
- Return Air Duct Connection, 2 1/2 inch
- Filter, Throwaway, 1-in.
- Filter Removal
- Bottom Access Panel
- Drain, 7/8-in. OD
- Drain Pan with Styrofoam Insulation
- Motor Junction Box
- Auxiliary Drip Lip (Optional, Shipped Loose)

42DF EXPOSED CEILING CABINET MODEL WITH SUPPLY AND RETURN AIR GRILLES

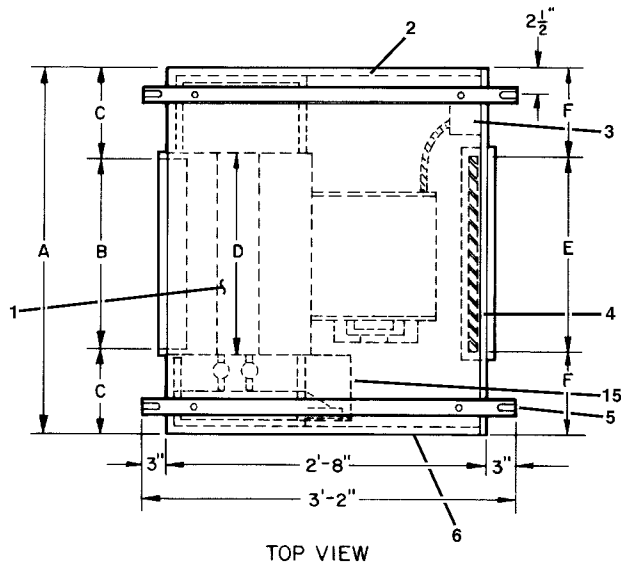

TOP VIEW

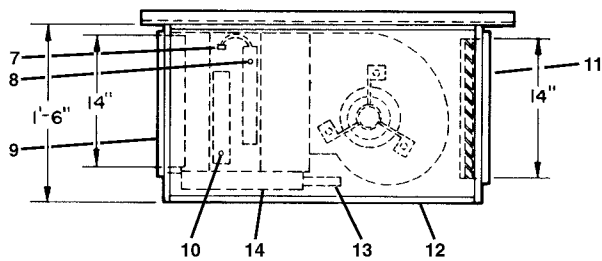

SIDE VIEW

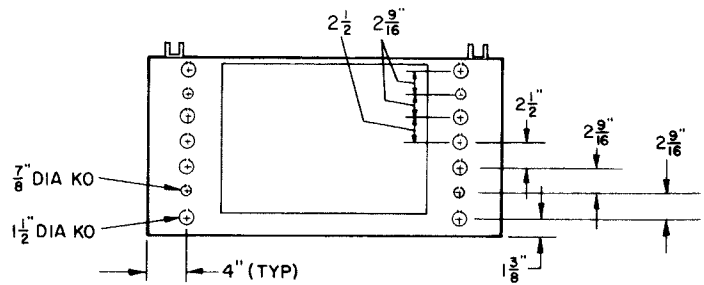

REAR PANEL ELEVATION

LEGEND

- 1 — Coil, 4-row
- 2 — Insulation, 1/2-in. Thick Fiberglass
- 3 — Junction Box
- 4 — Filter, Throwaway
- 5 — Unit Mounting Channel (2), 14-gage; 4 Mounting Slots, 1/2 in. x 2-in.
- 6 — Side Access Panel (2)
- 7 — Manual Air Vent
- 8 — Coil Outlet (See Table), Copper Sweat Connection
- 9 — Supply Air Grille (Double Deflection)
- 10 — Coil Inlet (See Table), Copper Sweat Connection
- 11 — Return Air Grille, Hinged, Bar Type, with Filter Frame (Anodized Aluminum Only)
- 12 — Bottom Access Panel
- 13 — Drain, 7/8-in. OD
- 14 — Drain Pan Insulated with Styrofoam
- 15 — Auxiliary Drip Lip

UNIT SIZE	NOM CFM	DIMENSIONS (in. ± 1/8)					
		A	B	C	D	E	F
06	600	31	13 1/2	8 3/4	15	14	8 1/2
08	800	36	18 1/2	8 3/4	20	20	8
10	1000	40	22 1/2	8 3/4	24	24	8
12	1200	45	27 1/2	8 3/4	29	28	8 1/2
14	1400	50	32 1/2	8 3/4	34	34	8
16	1600	55	37 1/2	8 3/4	39	38	8 1/2
18	1800	60	42 1/2	8 3/4	44	44	8
20	2000	64	46 1/2	8 3/4	48	48	8

NOTES:

- 1. R.H. unit shown; L.H. unit opposite.
- 2. Coil stub-out connection data available on request.
- 3. Units fabricated of galvanized steel with an Arctic White baked finish.
- 4. Internal parts fabricated of galvanized steel.
- 5. Sizes 06, 08 and 10 have one motor, one blower. Sizes 12 through 20 have 2 motors, 2 blowers.
- 6. Units must have drain line pitched and trapped externally.
- 7. Stamped supply and return grilles are not available.
- 8. Bottom return air is not available.
- 9. See 42DA-203-1 for optional coil connections.
- 10. Fan switch, wall plate not shown.

42D Series Units

Accessory dimensions



42D Series Units

42DA, DC, DE AND DF OPTIONAL COIL CONNECTION LOCATION SIZE 06 THRU 20

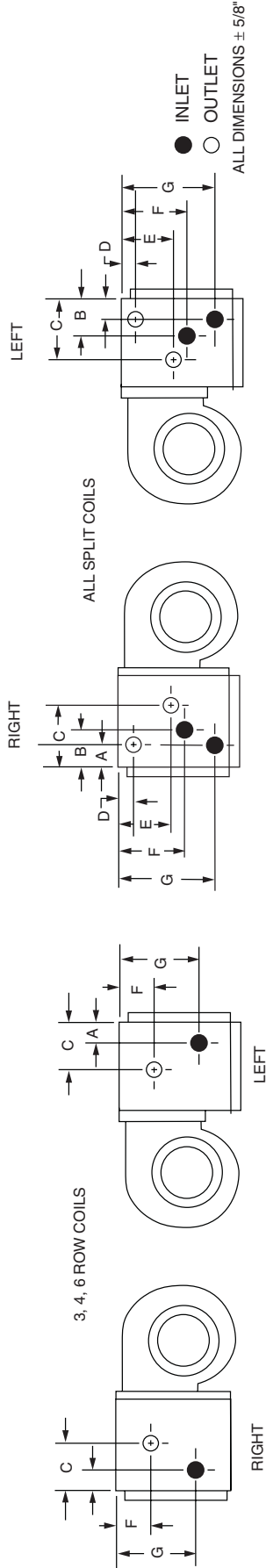

Unit Cfm	3-Row Coil						4-Row Coil						6-Row Coil						
	A	B	C	F	G	INLET/OUTLET	A	B	C	F	G	INLET/OUTLET	A	B	C	F	G	INLET/OUTLET	
Right Hand 600-800 600-2000	3 7/8		6	7 1/8	9 3/8	2 1/8	2 1/8	6 1/8	6 1/8	4 3/8	10 7/8	1 3/4	1 3/4	7 1/8	7 1/8	4 3/8	10 7/8	10 7/8	INLET
Left Hand 600-800 600-2000	3 7/8		6	7 1/8	9 3/8	2 1/8	2 1/8	6 1/8	6 1/8	4 3/8	10 7/8	1 3/4	1 3/4	7 1/8	7 1/8	4 3/8	10 7/8	10 7/8	OUTLET

Unit Cfm	3 and 1 Split Coil						3 and 2 Split Coil								
	A	B	C	D	E	INLET/OUTLET	A	B	C	D	E	F	G	INLET/OUTLET	
Right Hand 600-800 1000-2000	2 1/8	3 1/8	6 1/8	7 1/8	4 3/8	1 1/8	2 1/4	3 1/8	6 1/8	3/4	7 5/8	4 3/8	9 3/8	13 1/4	INLET
Left Hand 600-800 1000-2000	2 1/8	3 1/8	6 1/8	7 1/8	4 3/8	1 1/8	2 1/4	3 1/8	6 1/8	3/4	7 5/8	4 3/8	9 3/8	13 1/4	OUTLET

Unit Cfm	4 and 1 Split Coil						4 and 2 Split Coil							
	A	B	C	D	E	INLET/OUTLET	A	B	C	D	E	F	G	INLET/OUTLET
Right Hand 600-2000	3/4	2 1/8	6 1/8	7 1/8	4 3/8	1 1/8	2 1/4	3 1/8	7 1/8	3/4	4 3/8	10 7/8	13 1/4	INLET
Left Hand 600-2000	3/4	2 1/8	6 1/8	7 1/8	4 3/8	1 1/8	2 1/4	3 1/8	7 1/8	3/4	4 3/8	10 7/8	13 1/4	OUTLET

1. See Physical Data for piping knockout locations on DE and DF units.
2. Cooling coil is first in the air stream.

Unit Cfm	COIL CONNECTIONS (in.)					
	A	B	C	D	E	G
Right Hand 600-800 1000-2000	1 3/4	2 1/8	8 3/4	9 3/8	4 3/4	13 3/4
Left Hand 600-800 1000-2000	1 3/4	2 1/8	8 3/4	9 3/8	4 3/4	13 3/4

Unit Cfm	COIL CONNECTIONS (in.)					
	A	B	C	D	E	G
Right Hand 600-800 1000-2000	1 3/4	2 1/8	8 3/4	9 3/8	4 3/4	13 3/4
Left Hand 600-800 1000-2000	1 3/4	2 1/8	8 3/4	9 3/8	4 3/4	13 3/4

Unit Cfm	COIL CONNECTIONS (I.D. COPPER SWEAT) (in.)					
	1-2 ROW	3 ROW	4 ROW	6 ROW		
600	5/8	5/8	5/8	7/8		
800	5/8	5/8	5/8	7/8		
1000	5/8	7/8	7/8	7/8		
1200	5/8	7/8	7/8	7/8		
1400	5/8	7/8	7/8	1 1/8		
1600	5/8	7/8	7/8	1 1/8		
1800	5/8	1 1/8	1 1/8	1 1/8		
2000	5/8	1 1/8	1 1/8	1 1/8		

NOTE: Does not apply when optional valve packages are used.

42DD OPTIONAL COIL CONNECTION LOCATION SIZE 06 THRU 20

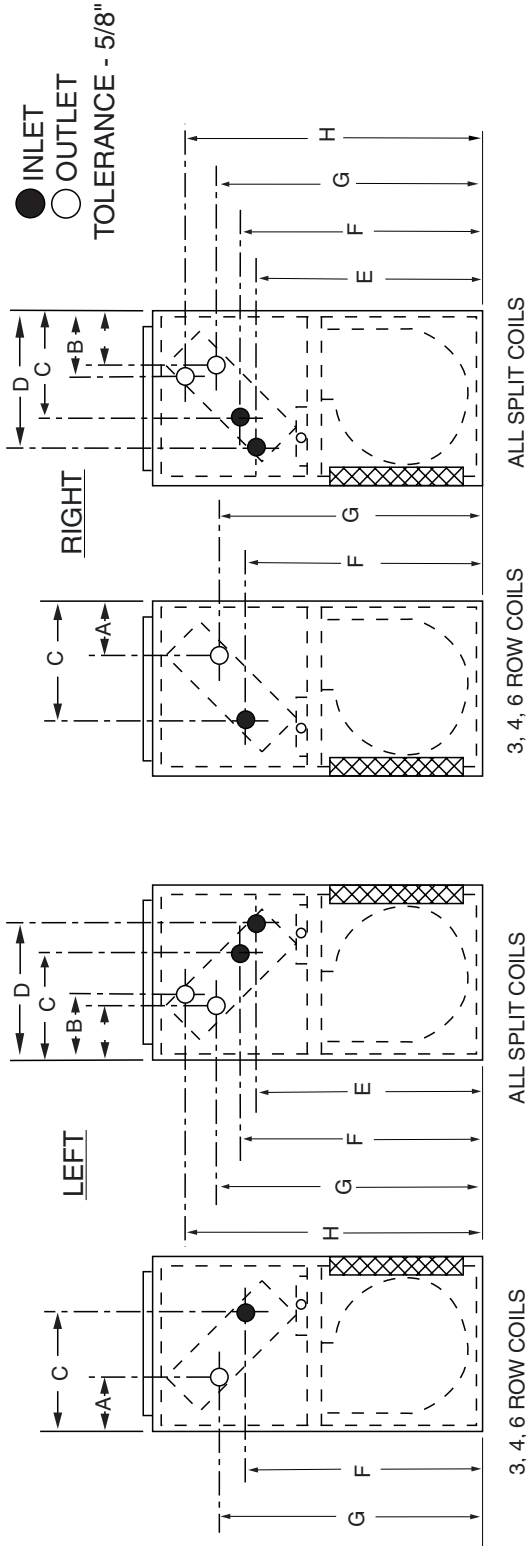

COIL CONNECTIONS SIZES (O.D. COPPER SWEAT) (in.)

Cfm	1-2 ROW	3 ROW	4 ROW	6 ROW
600	5/8	5/8	5/8	7/8
800	5/8	5/8	7/8	7/8
1000	5/8	7/8	7/8	7/8
1200	5/8	7/8	7/8	7/8
1400	5/8	7/8	1 1/8	1 1/8
1600	5/8	7/8	1 1/8	1 1/8
1800	5/8	1 1/8	1 1/8	1 1/8
2000	5/8	1 1/8	1 1/8	1 1/8

NOTE: Does not apply when optional valve packages are used.

COIL CONNECTIONS DIMENSIONS (in.)

Unit Cfm	3-Row Coil			4-Row Coil			6-Row Coil		
	A	B	C	A	B	C	A	B	C
Right Hand	6 1/16	8 1/2	26	4 1/2	26 1/2	3 1/2	11 1/8	23 13/16	25 7/8
Left Hand	7	8 7/8	25 1/2	4 3/4	25 15/16	3 7/8	10 3/4	24 1/2	25 5/8

COIL CONNECTIONS DIMENSIONS (in.)

Unit Cfm	3 And 1 Split Coil			3 And 2 Split Coil			H
	A	B	C	A	B	C	
Right Hand	5 3/4	7 1/8	25 1/8	5 1/8	7 1/8	12 3/4	24 7/16
Left Hand	4 1/4	6 1/8	24 1/8	4 3/4	6 1/8	12 3/4	23 3/16

COIL CONNECTIONS DIMENSIONS (in.)

Unit Cfm	4 And 1 Split Coil			4 And 2 Split Coil			H
	A	B	C	A	B	C	
Right Hand	4 7/16	5 13/16	10 7/16	3 1/2	5 9/16	12 3/4	22 13/16
Left Hand	4 1/4	6 1/16	9 7/8	3 1/8	5 1/16	12 3/4	23 7/16

NOTES:
 1. Does not apply when optional valve packages are used.
 2. Cooling coil is first in the airstream.

Accessory dimensions (cont)



SUPPLY GRILLES

SUPPLY GRILLE SIZES				
Unit Size	Nominal Cfm	Recommended Grille Sizes (in.)		
		Unit 42		
		DA, DC	DE	DD
06	600	14 x 14	15 x 14	15 x 15
08	800	19 x 14	20 x 14	20 x 15
10	1000	23 x 14	24 x 14	24 x 15
12	1200	28 x 14	29 x 14	29 x 15
14	1400	33 x 14	34 x 14	34 x 15
16	1600	38 x 14	39 x 14	39 x 15
18	1800	43 x 14	44 x 14	44 x 15
20	2000	47 x 14	48 x 14	48 x 15

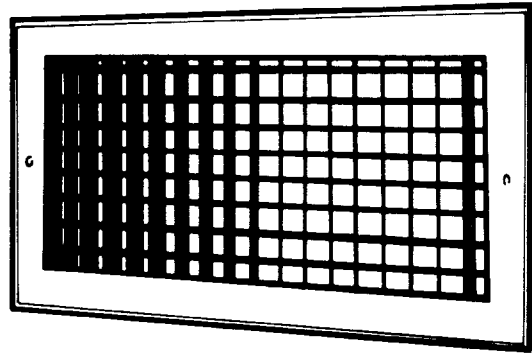

NOTE: Refer to Physical Data pages for actual unit supply opening dimensions. Field-furnished duct transitions may be required.

RETURN AIR GRILLES

RETURN AIR GRILLE SIZES				
Unit Size	Nominal Cfm	Recommended Grille Sizes (in.)		
		Unit 42		
		DA, DC	DE	DD
06	600	21 x 14	15 x 14	20 x 13
08	800	26 x 14	20 x 14	25 x 13
10	1000	30 x 14	24 x 14	29 x 13
12	1200	35 x 14	29 x 14	34 x 13
14	1400	40 x 14	34 x 14	39 x 13
16	1600	45 x 14	39 x 14	44 x 13
18	1800	50 x 14	44 x 14	49 x 13
20	2000	54 x 14	48 x 14	53 x 13

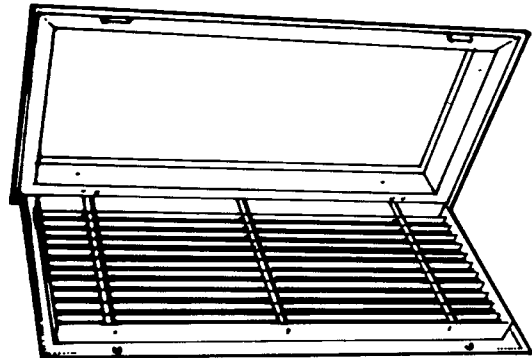

NOTES:
 1. Refer to Physical Data pages for actual return opening dimensions. Field-furnished duct transitions may be required.
 2. For return air grille filter sizes, contact Carrier.

42D Series Units

Performance data



42D COOLING CAPACITY (by GPM) 3-ROW COIL

UNIT SIZE	GPM	75 F DB/63 F WB									80 F DB/67 F WB									85 F DB/71 F WB														
		40 F EWT			45 F EWT			50 F EWT			40 F EWT			45 F EWT			50 F EWT			40 F EWT			45 F EWT			50 F EWT								
		ΔT	TC _b	SC _b	ΔT	TC _b	SC _b	ΔT	TC _b	SC _b	ΔT	TC _b	SC _b	ΔT	TC _b	SC _b	ΔT	TC _b	SC _b	ΔT	TC _b	SC _b	ΔT	TC _b	SC _b	ΔT	TC _b	SC _b	ΔT	TC _b	SC _b	ΔT	TC _b	SC _b
06	2	11.8	11.8	10.3	10.0	10.0	9.3	8.1	8.1	8.1	14.1	14.1	11.4	12.1	12.1	10.5	10.2	10.2	9.4	16.5	16.5	12.4	14.4	14.4	11.5	12.3	12.3	10.6	12.3	12.3	10.6	12.3	12.3	10.6
	3	9.3	14.0	11.4	7.7	11.5	10.3	6.2	9.3	8.9	11.3	16.9	12.6	9.5	14.2	11.5	7.8	11.7	10.4	13.3	20.0	13.7	11.5	17.2	12.7	9.6	14.4	11.6	9.6	14.4	11.6	9.6	14.4	11.6
	4	7.7	15.5	12.1	6.2	12.4	10.7	4.9	9.8	9.4	9.4	18.8	13.4	7.8	15.5	12.1	6.2	12.4	10.8	11.2	22.4	14.7	9.5	18.9	13.3	7.8	15.6	12.1	7.8	15.6	12.1	7.8	15.6	12.1
	5	6.5	16.3	12.5	5.2	13.1	11.1	4.1	10.1	9.6	8.0	19.9	13.9	6.6	16.5	12.5	5.2	13.1	11.1	9.5	23.7	15.7	8.1	20.2	13.8	6.6	16.6	12.5	6.6	16.6	12.5	6.6	16.6	12.5
	6	5.7	17.0	12.8	4.5	13.6	11.3	3.5	10.4	9.8	6.9	20.8	14.3	5.7	17.2	12.8	4.5	13.6	11.4	8.3	24.8	15.6	7.0	21.1	14.2	5.8	17.3	12.8	5.8	17.3	12.8	5.8	17.3	12.8
08	2	14.9	14.9	13.2	12.7	12.7	11.8	10.3	10.3	10.3	17.5	17.5	14.6	8.9	26.7	18.6	7.4	22.2	16.7	5.9	17.7	14.9	10.6	31.9	20.4	15.5	15.5	13.6	15.5	15.5	13.6	15.5	15.5	13.6
	4	11.8	17.7	14.8	9.8	14.7	13.3	8.1	12.1	11.5	14.1	21.2	16.3	10.2	25.4	18.1	8.5	21.1	16.3	6.8	17.0	14.6	12.1	30.2	19.7	12.1	18.2	15.0	12.1	18.2	15.0	12.1	18.2	15.0
	6	9.8	19.7	15.7	8.0	16.0	14.0	6.4	12.8	12.2	11.9	23.8	17.4	11.9	23.8	17.4	9.9	19.8	15.7	8.0	16.1	14.1	14.0	28.1	18.9	9.9	19.9	15.8	9.9	19.9	15.8	9.9	19.9	15.8
	8	8.4	20.9	16.3	6.8	16.9	14.5	5.3	13.3	12.7	10.2	25.4	18.1	14.1	21.2	16.3	12.0	18.0	14.9	9.9	14.9	13.4	16.7	25.0	17.7	8.5	21.2	16.3	8.5	21.2	16.3	8.5	21.2	16.3
	10	7.3	21.9	16.8	5.9	17.6	14.9	4.6	13.7	13.0	8.9	26.7	18.6	17.5	17.5	14.6	15.2	15.2	13.4	12.9	12.9	13.0	20.4	20.4	15.8	7.4	22.3	16.8	7.4	22.3	16.8	7.4	22.3	16.8
10	2	15.9	15.9	14.7	13.8	13.8	13.0	11.0	11.0	11.0	18.6	18.6	16.3	16.4	16.4	14.9	14.1	14.1	13.2	21.4	21.4	17.8	19.1	19.1	16.6	16.8	16.8	15.2	16.8	16.8	15.2	16.8	16.8	15.2
	4	10.9	21.8	18.3	9.1	18.2	16.5	7.5	15.1	14.3	13.0	26.1	20.1	11.1	22.2	18.5	9.3	18.6	16.7	15.3	30.7	21.8	13.3	26.6	20.3	11.3	22.6	18.7	11.3	22.6	18.7	11.3	22.6	18.7
	6	8.4	25.2	19.9	6.8	20.5	17.8	5.4	16.3	15.5	10.2	30.5	22.0	8.5	25.5	20.0	6.9	20.6	17.9	12.1	36.2	24.0	10.3	30.9	22.0	8.5	25.6	20.0	8.5	25.6	20.0	8.5	25.6	20.0
	8	6.8	27.2	20.8	5.5	21.9	18.5	4.3	17.1	16.1	8.3	33.1	23.1	6.9	27.5	20.8	5.5	21.9	18.6	9.8	39.4	25.2	8.4	33.6	23.0	6.9	27.7	20.8	6.9	27.7	20.8	6.9	27.7	20.8
	10	5.7	28.6	21.4	4.6	22.9	18.9	3.5	17.6	16.5	7.0	34.9	23.8	5.8	28.9	21.4	4.6	22.9	19.0	8.3	41.6	26.1	7.1	35.5	23.7	5.8	29.1	21.4	5.8	29.1	21.4	5.8	29.1	21.4
12	2	18.1	18.1	16.6	15.6	15.6	14.6	12.4	12.4	12.4	21.1	21.1	18.6	18.6	18.6	16.9	16.0	16.0	14.9	24.2	24.2	20.4	21.6	21.6	18.9	19.1	19.1	17.2	19.1	19.1	17.2	19.1	19.1	17.2
	4	12.6	25.1	21.3	10.6	21.2	19.2	8.8	17.6	16.6	15.0	29.9	23.5	12.8	25.6	21.6	10.8	21.6	19.5	17.5	35.1	25.5	15.3	30.5	23.7	13.0	26.1	21.9	13.0	26.1	21.9	13.0	26.1	21.9
	6	9.7	29.2	23.4	8.0	23.9	20.9	6.4	19.3	18.2	11.8	35.3	25.8	9.9	29.6	23.5	8.0	24.1	21.1	13.9	41.8	28.1	11.9	35.7	25.8	9.9	29.8	23.6	9.9	29.8	23.6	9.9	29.8	23.6
	8	7.9	31.7	24.5	6.4	25.6	21.8	5.0	20.2	19.0	9.6	38.5	27.2	8.0	32.0	24.5	6.4	25.7	22.0	11.5	45.9	29.7	9.8	39.1	27.1	8.1	32.3	24.6	8.1	32.3	24.6	8.1	32.3	24.6
	10	6.7	33.5	25.3	5.4	26.9	22.4	4.2	20.8	19.5	8.2	40.8	28.1	6.8	33.8	25.3	5.4	26.9	22.5	9.7	48.7	30.8	8.3	41.5	28.0	6.8	34.1	25.3	6.8	34.1	25.3	6.8	34.1	25.3
14	4	13.3	26.6	23.4	11.4	22.7	20.9	9.0	17.9	17.9	15.7	31.4	25.8	13.6	27.2	23.7	11.6	23.3	21.3	18.3	36.6	27.9	16.1	32.1	26.1	13.9	27.9	24.1	13.9	27.9	24.1	13.9	27.9	24.1
	6	10.5	31.4	26.0	8.7	26.2	23.4	7.2	21.5	20.3	12.6	37.7	28.6	10.7	32.1	26.3	8.9	26.6	23.7	14.9	44.6	31.1	12.8	38.5	28.9	10.8	32.5	26.5	10.8	32.5	26.5	10.8	32.5	26.5
	8	8.7	34.8	27.6	7.1	28.5	24.7	5.7	22.8	21.5	10.5	42.1	30.5	8.8	35.3	27.7	7.2	28.6	24.9	12.5	50.0	33.2	10.7	42.9	30.6	8.9	35.6	27.8	8.9	35.6	27.8	8.9	35.6	27.8
	10	7.4	37.1	28.7	6.0	30.0	25.5	4.7	23.6	22.2	9.0	45.1	31.8	7.5	37.5	28.7	6.0	30.1	25.6	10.8	53.8	34.7	9.2	45.8	31.7	7.6	37.8	28.7	7.6	37.8	28.7	7.6	37.8	28.7
	12	6.5	38.8	29.4	5.2	31.1	26.0	4.0	24.2	22.7	7.9	47.3	32.7	6.5	39.2	29.4	5.2	31.2	26.2	9.4	56.4	35.8	8.0	48.1	32.5	6.6	39.5	29.4	6.6	39.5	29.4	6.6	39.5	29.4
16	4	14.8	29.6	26.1	12.7	25.3	23.3	9.9	19.9	19.9	17.4	34.8	28.8	15.2	30.3	26.4	13.0	26.0	23.7	20.2	40.4	31.2	17.8	35.6	29.2	15.5	31.1	26.9	15.5	31.1	26.9	15.5	31.1	26.9
	6	11.7	35.1	29.2	9.8	29.4	26.3	8.1	24.2	22.8	14.0	41.8	32.2	11.9	35.7	29.5	10.0	29.9	26.7	16.5	49.4	35.0	14.3	42.8	32.5	12.1	36.2	29.8	12.1	36.2	29.8	12.1	36.2	29.8
	8	9.7	38.9	31.1	8.0	32.0	27.9	6.4	25.8	24.3	11.7	46.9	34.4	9.9	39.5	31.3	8.1	32.2	28.1	14.0	55.9	37.5	11.2	44.8	34.5	10.0	39.8	31.4	10.0	39.8	31.4	10.0	39.8	31.4
	10	8.3	41.7	32.4	6.7	33.7	28.9	5.3	26.7	25.1	10.1	50.5	35.9	8.4	42.1	32.4	6.8	33.9	29.0	12.0	60.1	39.1	10.2	51.2	35.8	8.5	42.4	32.5	8.5	42.4	32.5	8.5	42.4	32.5
	12	7.3	43.6	33.3	5.9	35.1	29.5	4.6	27.4	25.7	7.2	43.1	36.9	7.3	44.1	33.3	5.9	35.2	29.7	10.5	63.3	40.4	9.0	53.9	36.8	7.4	44.4	33.3	7.4	44.4	33.3	7.4	44.4	33.3
18	4	16.2	32.5	28.7	14.0	27.9	25.6	10.9	21.8	21.8	19.0	38.1	31.7	16.6	33.3	29.1	14.3	28.6	26.0	22.0	44.0	34.4	19.5	39.0	32.1	17.1	34.2	29.6	17.1	34.2	29.6	17.1	34.2	29.6
	6	12.9	38.6	32.4	10.8	32.5	29.2	9.0	26.9	25.2	15.3	46.0	35.7	13.1	39.4	32.8	11.0	33.1	29.5	18.0	54.0	38.7	15.6	46.9	36.0	13.3	39.9	33.1	13.3	39.9	33.1	13.3	39.9	33.1
	8	10.7	42.9	34.6	8.9	35.5	31.1	7.2	28.8	27.0	12.9	51.6	38.1	10.9	43.6	34.8	8.9	35.8	31.4	15.3	61.3	41.6	13.1	52.5	38.3	11.0	43.9	35.0	11.0	43.9	35.0	11.0	43.9	35.0
	10	9.2	46.1	36.1	7.5	37.5	32.2	6.0	29.9	28.1	11.2	55.8	39.9	9.3	46.5	36.8	7.5	37.7	32.4	13.2	66.2	43.5	11.3	56.5	39.8	9.4	46.9	36.2	9.4	46.9	36.2	9.4	46.9	36.2
	12	8.1	48.4	37.1	6.5	39.0	33.0	5.1	30.7	28.8	9.8	58.8	41.2	8.1	48.9	37.1	6.5	39.2	33.2	11.7	69.9	45.0	9.9	59.6	41.0	8.2	49.2	37.2	8.2	49.2	37.2	8.2	49.2	37.2
20	4	17.4	34.8	30.9	15.0	29.9	27.4	11.7	23.4	23.4	20.4	40.7	34.2	17.9	35.7	31.3	15.4	30.8	27.9	23.5	47.0	37.1	18.3	36.6	31.7	23.5	47.0	37.1	23.5	47.0	37.1	23.5	47.0	37.1
	6	13.9	41.6	35.2	11.7	35.2	31.7	9.7	29.2	27.2	16.5	49.4	38.8	14.1	42.4	35.6	11.9	35.8	32.0	19.2	57.7	42.0	14.3	43.0	35.9	19.2	57.7	42.0	19.2	57.7	42.0	19.2	57.7	42.0
	8	11.6	46.3	37.7	9.6	38.5	33.9	7.8	31.4	29.4	14.0	55.9	41.7	11.8	47.1	38.0	9.7	38.9	34.2	16.5	65.9	45.3	11.9	47.5	38.2	16.5	65.9	45.3	16.5	65.9	45.3			

Performance data (cont)



42D COOLING CAPACITY (by GPM) 6-ROW COIL

UNIT SIZE	GPM	75 F DB/63 F WB									80 F DB/67 F WB									85 F DB/71 F WB												
		40 F EWT			45 F EWT			50 F EWT			40 F EWT			45 F EWT			50 F EWT			40 F EWT			45 F EWT			50 F EWT						
		ΔT	TC _b	SC _b	ΔT	TC _b	SC _b	ΔT	TC _b	SC _b	ΔT	TC _b	SC _b	ΔT	TC _b	SC _b	ΔT	TC _b	SC _b	ΔT	TC _b	SC _b	ΔT	TC _b	SC _b	ΔT	TC _b	SC _b	ΔT	TC _b	SC _b	ΔT
06	4	10.5	15.7	20.9	8.7	14.1	17.3	7.0	12.5	14.0	12.6	17.4	25.2	10.7	15.7	21.4	8.8	14.2	17.7	15.0	18.9	29.9	12.9	17.3	25.9	10.9	15.8	21.9				
	6	7.9	17.0	23.7	6.5	15.0	19.4	5.1	13.2	15.2	9.6	19.0	28.9	8.1	17.0	24.3	6.6	15.1	19.7	11.5	20.8	34.5	9.9	18.9	29.8	8.3	17.0	24.9				
	8	6.4	17.8	25.4	5.1	15.5	20.5	3.9	13.4	15.7	7.8	19.9	31.1	6.5	17.7	25.9	5.2	15.5	20.7	9.3	22.0	37.1	7.9	19.7	31.8	6.6	17.6	26.3				
	10	5.3	18.2	26.3	4.2	15.8	21.2	3.2	13.6	16.1	6.4	20.4	32.1	5.4	18.1	26.9	4.3	15.8	21.4	7.7	22.6	38.4	6.6	20.2	33.0	5.5	18.0	27.4				
	12	4.5	18.5	26.9	3.6	16.1	21.7	2.7	13.8	16.4	5.5	20.8	32.9	4.6	18.4	27.6	3.7	16.0	22.0	6.6	23.0	39.4	5.7	20.6	34.0	4.7	18.3	28.2				
08	4	13.3	20.3	26.6	11.2	18.4	22.3	9.2	16.4	18.5	15.9	22.4	31.9	13.6	20.4	27.3	11.4	18.6	22.8	18.9	24.4	37.7	16.4	22.4	32.7	13.9	20.6	27.9				
	6	10.2	22.2	30.5	8.4	19.7	25.1	6.7	17.4	20.0	12.4	24.7	37.1	10.4	22.1	31.2	8.5	19.8	25.5	14.7	27.0	44.2	12.7	24.6	38.1	10.6	22.1	31.9				
	8	8.3	23.3	33.0	6.7	20.4	26.7	5.2	17.8	20.7	10.1	26.0	40.2	8.4	23.1	33.6	6.7	20.4	26.9	12.0	28.6	47.9	10.3	25.7	41.1	8.5	23.0	34.1				
	10	6.9	23.9	34.4	5.5	20.9	27.7	4.3	18.1	21.3	8.4	26.8	41.9	7.0	23.8	35.1	5.6	20.8	28.0	10.0	29.5	50.0	8.6	26.5	43.0	7.1	23.6	35.7				
	12	5.9	24.4	35.3	4.7	21.2	28.5	3.6	18.2	21.7	7.2	27.4	43.1	6.0	24.2	36.2	4.8	21.2	28.8	8.6	30.2	51.5	7.4	27.1	44.4	6.1	24.1	36.9				
10	4	15.7	31.5	24.5	13.3	26.6	22.2	9.9	19.9	19.9	18.7	37.5	26.9	16.1	32.2	24.7	13.6	27.2	22.5	22.0	44.0	29.2	19.2	38.4	27.0	16.5	32.9	24.9				
	6	12.1	36.4	26.8	10.0	30.1	24.0	8.1	24.3	21.3	14.7	44.1	29.8	12.4	37.2	26.8	10.2	30.6	24.1	17.4	52.3	32.5	15.1	45.2	29.7	12.6	37.8	26.9				
	8	9.9	39.6	28.3	8.0	32.2	24.9	6.3	25.3	21.8	12.0	48.1	31.6	10.1	40.3	28.2	8.1	32.5	25.0	14.3	57.2	34.6	12.3	49.2	31.2	10.2	40.8	28.0				
	10	8.3	41.5	29.2	6.7	33.6	25.6	5.2	26.0	22.3	10.1	50.6	32.6	8.5	42.3	29.0	6.8	33.9	25.6	12.0	60.2	35.9	10.4	51.8	32.3	8.6	43.0	28.9				
	12	7.2	42.9	29.9	5.8	34.6	26.1	4.4	26.5	22.5	8.7	52.3	33.4	7.3	43.8	29.7	5.8	35.0	26.0	10.4	62.4	36.8	8.9	53.7	33.1	7.4	44.6	29.5				
12	4	18.1	36.2	28.6	15.5	30.9	26.1	11.5	23.1	23.1	21.4	42.8	31.3	18.5	37.0	28.9	15.9	31.8	26.5	21.4	42.8	31.3	18.5	37.0	28.9	15.9	31.8	26.5				
	6	14.1	42.2	31.5	11.7	35.1	28.3	9.6	28.9	25.3	17.0	50.9	34.8	14.4	43.1	31.6	11.9	35.8	28.5	17.0	50.9	34.8	14.4	43.1	31.6	11.9	35.8	28.5				
	8	11.6	46.2	33.4	9.4	37.8	29.5	7.5	30.1	26.1	14.0	56.1	37.1	11.7	46.9	33.2	9.6	38.2	29.6	14.0	56.1	37.1	11.7	46.9	33.2	9.6	38.2	29.6				
	10	9.8	48.8	34.6	7.9	39.5	30.3	6.2	30.9	26.5	11.9	59.3	38.5	9.9	49.6	34.3	8.0	39.9	30.4	11.9	59.3	38.5	9.9	49.6	34.3	8.0	39.9	30.4				
	12	8.4	50.6	35.4	6.8	40.8	30.9	5.3	31.6	26.9	10.3	61.6	39.6	8.6	51.5	35.2	6.9	41.2	30.9	10.3	61.6	39.6	8.6	51.5	35.2	6.9	41.2	30.9				
14	3	21.4	32.1	28.0	16.6	25.0	25.0	13.9	20.9	20.9	25.0	37.5	30.8	22.3	33.4	28.6	16.9	25.4	25.4	28.7	43.1	33.4	25.9	38.9	31.4	23.2	34.7	29.1				
	7	13.6	47.5	35.9	11.4	39.9	32.5	9.5	33.2	29.1	16.3	56.9	39.6	13.9	48.7	36.1	11.7	40.8	32.8	19.2	67.3	43.1	16.7	58.4	39.6	14.2	49.8	36.4				
	11	10.0	54.9	39.4	8.2	44.9	34.9	6.5	35.6	30.7	12.1	66.7	43.9	10.2	55.9	39.2	8.3	45.5	35.0	14.4	79.5	48.1	12.4	68.2	43.5	10.3	56.9	39.1				
	15	7.9	58.9	41.3	6.3	47.6	36.1	4.9	36.9	31.4	9.6	71.7	46.1	8.0	60.1	41.0	6.4	48.1	36.1	11.4	85.4	50.7	9.8	73.6	45.7	8.1	61.1	40.8				
	19	6.4	61.2	42.4	5.2	49.3	36.9	4.0	37.7	31.8	7.9	74.6	47.5	6.6	62.6	42.1	5.3	49.9	36.8	9.4	89.1	52.4	8.1	76.8	47.0	6.7	63.8	41.8				
16	3	23.3	35.0	30.7	18.1	27.2	27.2	15.1	22.7	22.7	27.4	41.1	34.3	24.3	36.5	31.3	18.4	27.6	27.6	31.4	47.1	37.0	28.3	42.5	34.8	25.4	38.1	31.9				
	7	15.1	53.0	40.4	12.8	44.8	36.6	10.7	37.6	32.8	18.1	63.3	44.5	15.5	54.3	40.7	13.1	45.9	37.1	21.3	74.6	48.4	18.5	64.9	44.5	15.9	55.6	41.0				
	11	11.2	61.6	44.5	9.2	50.5	39.5	7.4	40.5	34.9	13.6	74.7	49.5	11.4	62.6	44.3	9.3	51.4	39.6	16.1	88.7	54.1	13.9	76.2	49.0	11.6	63.9	42.2				
	15	8.9	66.4	46.8	7.2	53.8	41.0	5.6	42.0	35.7	10.8	80.8	52.2	9.0	67.7	46.4	7.2	54.4	40.9	12.8	96.2	57.3	11.0	82.8	51.7	9.2	68.7	46.2				
	19	7.3	69.3	48.1	5.9	55.8	41.9	4.5	43.0	36.3	8.9	84.4	53.9	7.4	70.7	47.8	5.9	56.5	41.8	10.6	100.7	59.3	9.1	86.7	53.3	7.6	72.0	47.4				
18	5	20.2	50.5	40.9	17.5	43.9	37.4	12.9	32.2	32.2	23.7	59.3	44.7	20.8	52.1	41.5	18.3	45.6	38.2	20.2	50.5	40.9	17.5	43.9	37.4	12.9	32.2	32.2				
	9	14.2	63.8	47.5	11.9	53.3	42.7	9.8	44.2	38.3	17.1	76.8	52.5	14.5	65.3	47.6	12.1	54.4	43.0	14.2	63.8	47.5	11.9	53.3	42.7	9.8	44.2	38.3				
	13	11.0	71.5	51.1	9.0	58.3	45.1	7.1	46.3	39.7	13.3	86.6	56.8	11.2	72.6	50.7	9.1	59.0	45.1	11.0	71.5	51.1	9.0	58.3	45.1	7.1	46.3	39.7				
	17	8.9	75.6	53.0	7.2	61.2	46.4	5.6	47.7	40.4	10.8	92.0	59.2	9.1	77.1	52.6	7.3	61.9	46.3	8.9	75.6	53.0	7.2	61.2	46.4	5.6	47.7	40.4				
	21	7.5	78.4	54.4	6.0	63.2	47.4	4.6	48.6	41.0	9.1	95.5	60.9	7.6	80.1	54.0	6.1	64.0	47.2	7.5	78.4	54.4	6.0	63.2	47.4	4.6	48.6	41.0				
20	5	21.7	54.2	44.4	18.9	47.2	40.5	13.8	34.6	34.6	25.4	63.4	48.6	22.4	55.9	45.1	19.7	49.1	41.2	29.3	73.3	52.4	26.1	65.3	49.1	23.2	57.9	45.9				
	9	15.3	69.0	51.8	12.9	58.0	46.8	10.8	48.4	41.9	18.4	82.7	57.2	15.7	70.6	52.0	13.1	59.2	47.1	21.7	97.7	62.2	18.8	84.5	56.9	15.9	71.8	52.1				
	13	11.9	77.7	55.9	9.8	63.6	49.5	7.8	50.9	43.7	14.5	94.0	62.1	12.1	78.8	55.6	9.9	64.4	49.5	17.1	111.4	67.9	14.7	95.8	61.5	12.3	79.9	55.3				
	17	9.7	82.5	58.2	7.9	66.9	51.0	6.2	52.4	44.5	11.8	100.2	64.9	9.9	84.0	57.8	7.9	67.6	51.0	14.0	119.2	71.2	12.1	102.6	64.2	10.0	85.2	57.4				
	21	8.2	85.7	59.7	6.6	69.2	52.1	5.1	53.5	45.2	9.9	104.4	66.8	8.3	87.5	59.3	6.7	70.0	52.0	11.8	124.4	73.5	10.2	107.1	66.1	8.5	89.0	58.9				

LEGEND

ΔT — Temperature Change	SC _b — Base Sensible Capacity from Base Cooling Capacities by Gpm charts
DB — Dry Bulb	TC _b — Base Total Capacity from Base Cooling Capacities by Gpm charts
EWT — Entering Water Temperature	WB — Wet Bulb
GPM — Gallons Per Minute	

NOTE: All capacities are given in thousands of Btu/h (MBtu/h).

42D Series Units



42D COOLING CAPACITY (by ΔT) 3-ROW COIL

UNIT SIZE	ΔT	75 F DB/63 F WB									80 F DB/67 F WB									85 F DB/71 F WB												
		40 F EWT			45 F EWT			50 F EWT			40° F EWT			45 F EWT			50 F EWT			40 F EWT			45 F EWT			50 F EWT						
		GPM	TC _b	SC _b	GPM	TC _b	SC _b	GPM	TC _b	SC _b	GPM	TC _b	SC _b	GPM	TC _b	SC _b	GPM	TC _b	SC _b	GPM	TC _b	SC _b	GPM	TC _b	SC _b	GPM	TC _b	SC _b	GPM	TC _b	SC _b	GPM
06	4	—	—	—	7.0	14.0	11.5	—	—	—	—	—	—	—	—	—	—	—	—	—	—	—	—	—	—	—	—	—	—	—	—	
	6	5.6	16.7	12.7	4.2	12.5	10.8	3.2	9.4	9.0	—	7.2	21.6	14.6	—	5.7	17.0	12.7	4.2	12.6	10.9	—	—	—	—	—	—	—	—	—	—	
	8	3.8	15.2	12.0	2.8	11.3	10.1	2.0	8.2	8.1	—	5.0	19.8	13.9	3.9	15.3	12.0	2.9	11.5	10.3	—	—	—	—	—	—	—	—	—	—	—	
	10	2.7	13.4	11.1	2.0	10.0	9.3	1.4	7.0	7.0	—	3.7	18.2	13.2	2.8	13.8	11.3	—	—	—	—	—	—	—	—	—	—	—	—	—	—	
	12	2.0	11.7	10.3	1.5	8.8	8.3	—	—	—	—	2.7	16.1	12.3	—	—	—	—	—	—	—	—	—	—	—	—	—	—	—	—	—	
08	4	—	—	—	—	—	—	—	—	—	—	—	—	—	—	—	—	—	—	—	—	—	—	—	—	—	—	—	—	—	—	
	6	7.6	23.2	17.3	5.9	17.5	14.8	4.4	13.0	12.4	—	—	—	—	—	—	—	—	—	—	—	—	—	—	—	—	—	—	—	—	—	
	8	5.4	21.3	16.5	4.0	16.0	14.0	3.0	12.1	11.6	—	6.9	27.7	19.0	5.4	21.6	16.5	4.0	16.1	14.1	—	—	—	—	—	—	—	—	—	—	—	
	10	3.9	19.5	15.6	2.9	14.6	13.2	2.1	10.6	10.4	—	5.1	25.6	18.1	3.9	19.7	15.7	3.0	14.9	13.4	—	—	—	—	—	—	—	—	—	—	—	
	12	2.9	17.5	14.7	2.2	13.2	12.2	—	—	—	—	3.9	23.6	17.3	3.0	18.0	14.9	2.3	13.6	12.5	—	—	—	—	—	—	—	—	—	—	—	
10	4	—	—	—	11.7	23.5	19.2	—	—	—	—	—	—	—	—	—	—	—	—	—	—	—	—	—	—	—	—	—	—	—	—	
	6	9.5	28.2	21.2	7.2	21.3	18.2	5.5	16.0	15.2	—	11.9	36.2	24.4	—	9.6	28.6	21.2	7.3	21.4	18.3	—	—	—	—	—	—	—	—	—	—	
	8	6.5	25.7	20.1	5.0	19.4	17.1	3.6	14.4	13.9	—	8.4	33.5	23.2	6.6	26.1	20.2	5.1	19.6	17.4	—	—	—	—	—	—	—	—	—	—	—	
	10	4.7	23.0	18.9	3.5	17.4	15.9	2.4	12.1	12.1	—	6.2	30.8	22.1	4.8	23.6	19.1	3.6	17.9	16.3	—	—	—	—	—	—	—	—	—	—	—	
	12	3.4	20.4	17.6	2.6	15.5	14.5	1.7	9.9	9.9	—	4.7	27.7	20.8	3.6	21.1	17.9	2.7	16.2	14.9	—	—	—	—	—	—	—	—	—	—	—	
12	6	11.4	34.5	25.8	8.8	26.1	22.1	6.6	19.5	18.5	—	—	—	—	11.6	35.0	25.8	8.8	26.2	22.2	—	—	—	—	—	—	—	—	—	—	—	
	8	7.9	31.6	24.5	6.0	23.9	20.9	4.7	18.1	17.1	—	10.3	41.1	28.2	8.0	32.1	24.6	6.0	24.1	21.1	—	—	—	—	—	—	—	—	—	—	—	
	10	5.8	28.9	23.2	4.3	21.8	19.7	3.0	15.2	15.2	—	7.7	38.0	26.9	5.9	29.4	23.4	4.6	22.3	19.9	—	—	—	—	—	—	—	—	—	—	—	
	12	4.2	25.8	21.7	3.3	19.8	18.2	2.2	12.9	12.9	—	5.8	34.9	25.6	4.3	26.6	22.2	3.5	20.4	18.6	—	—	—	—	—	—	—	—	—	—	—	
	14	3.3	23.3	20.4	2.5	17.6	16.4	—	—	—	—	4.4	31.4	24.2	3.4	24.1	20.9	2.6	18.4	17.0	—	—	—	—	—	—	—	—	—	—	—	
14	6	13.3	39.6	29.7	10.0	29.9	25.5	7.4	22.5	21.3	—	—	—	—	13.4	40.2	29.8	10.0	30.1	25.6	—	—	—	—	—	—	—	—	—	—	—	
	8	9.1	36.1	28.2	6.9	27.2	24.0	5.2	20.6	19.5	—	11.8	47.1	32.6	9.3	36.7	28.3	7.0	27.7	24.3	—	—	—	—	—	—	—	—	—	—	—	
	10	6.5	32.3	26.4	4.9	24.5	22.3	3.3	16.4	16.4	—	8.7	43.2	31.0	6.7	33.3	26.8	5.0	25.3	22.8	—	—	—	—	—	—	—	—	—	—	—	
	12	4.8	28.7	24.6	3.7	21.8	20.2	2.1	12.7	12.7	—	6.6	39.0	29.2	5.0	29.8	25.1	3.8	22.8	20.9	—	—	—	—	—	—	—	—	—	—	—	
	14	3.7	25.4	22.6	2.5	17.4	16.7	—	—	—	—	5.0	34.8	27.4	3.8	26.6	23.3	2.8	19.3	18.1	—	—	—	—	—	—	—	—	—	—	—	
16	6	15.1	46.0	34.3	11.7	34.9	29.4	8.8	26.2	24.6	—	—	—	—	—	—	—	11.7	35.0	29.6	—	—	—	—	—	—	—	—	—	—	—	
	8	7.7	38.4	30.9	5.8	29.1	26.1	4.0	19.8	19.8	—	10.1	50.8	36.0	7.9	39.3	31.2	6.0	29.8	26.6	—	—	—	—	—	—	—	—	—	—	—	
	10	4.4	30.9	26.9	3.3	23.2	21.5	—	—	—	—	6.0	41.9	32.2	4.6	32.2	27.6	3.5	24.5	22.4	—	—	—	—	—	—	—	—	—	—	—	
	12	2.6	23.3	21.4	—	—	—	—	—	—	—	3.8	33.6	28.1	—	—	—	—	—	—	—	—	—	—	—	—	—	—	—	—	—	
	22	—	—	—	—	—	—	—	—	—	—	—	—	—	—	—	—	—	—	—	—	—	—	—	—	—	—	—	—	—	—	
18	6	—	—	—	13.4	39.9	33.4	9.9	29.9	28.0	—	—	—	—	—	—	—	—	—	—	—	—	—	—	—	—	—	—	—	—	—	
	8	9.0	44.5	35.3	6.6	33.7	30.0	4.7	23.2	23.2	—	11.7	58.3	41.0	—	—	—	—	—	—	—	—	—	—	—	—	—	—	—	—	—	
	10	5.2	36.5	31.3	4.0	27.8	25.5	—	—	—	—	7.1	49.1	37.0	5.4	37.8	31.9	4.1	29.1	26.4	—	—	—	—	—	—	—	—	—	—	—	
	12	3.2	28.9	26.0	—	—	—	—	—	—	—	4.5	40.2	32.9	3.4	31.5	28.0	—	—	—	—	—	—	—	—	—	—	—	—	—	—	—
	22	—	—	—	—	—	—	—	—	—	—	2.9	31.8	27.8	—	—	—	—	—	—	—	—	—	—	—	—	—	—	—	—	—	—
20	6	—	—	—	14.7	44.3	37.1	11.1	33.2	31.1	—	—	—	—	—	—	—	—	—	—	—	—	—	—	—	—	—	—	—	—	—	
	8	10.0	49.8	39.3	7.6	37.9	33.5	5.5	27.5	26.5	—	13.1	65.0	45.5	10.1	50.5	39.5	7.7	38.5	33.9	—	—	—	—	—	—	—	—	—	—	—	
	10	5.9	41.3	35.0	4.5	31.6	28.8	2.5	17.5	17.5	—	8.0	55.8	41.6	6.1	42.7	35.7	4.7	32.9	29.7	—	—	—	—	—	—	—	—	—	—	—	
	12	3.8	33.6	30.0	—	—	—	—	—	—	—	5.1	45.7	37.0	3.9	35.4	31.1	—	—	—	—	—	—	—	—	—	—	—	—	—	—	—
	22	—	—	—	—	—	—	—	—	—	—	3.4	37.0	31.8	—	—	—	—	—	—	—	—	—	—	—	—	—	—	—	—	—	—

See Legend on page 80.

42D COOLING CAPACITY (by ΔT) 4-ROW COIL

UNIT SIZE	ΔT	75 F DB/63 F WB									80 F DB/67 F WB									85 F DB/71 F WB											
		40 F EWT			45 F EWT			50 F EWT			40 F EWT			45 F EWT			50 F EWT			40 F EWT			45 F EWT			50 F EWT					
		GPM	TC _b	SC _b	GPM	TC _b	SC _b	GPM	TC _b	SC _b	GPM	TC _b	SC _b	GPM	TC _b	SC _b	GPM	TC _b	SC _b	GPM	TC _b	SC _b	GPM	TC _b	SC _b	GPM	TC _b	SC _b	GPM	TC _b	SC _b
06	4	10.8	21.4	15.4	8.2	16.4	13.2	6.1	12.1	11.2	—	—	—	—	—	—	—	—	—	—	—	—	—	—	—	—	—	—	—	—	—
	6	6.5	19.2	14.4	4.8	14.4	12.2	3.6	10.8	10.1	—	8.4	25.1	16.7	6.0	19.7	14.5	4.9	14.8	12.4	—	—	—	—	—	—	—	—	—	—	—
	8	4.2	16.6	13.2	3.1	12.5	11.2	2.2	8.6	8.5	—	5.6	22.3	15.6	4.3	17.1	13.4	3.2	12.9	11.5	—	—	—	—	—	—	—	—	—	—	—
	10	2.9	14.3	12.1	2.2	10.9	10.0	—	—	—	—	3.9	19.4	14.3	3.0	14.9	12.4	2.3	11.4	10.4	—	—	—	—	—	—	—	—	—	—	—
	12	2.1	12.3	11.0	—	—	—	—	—	—	—	2.8	16.9	13.2	2.2	13.0	11.3	—	—	—	—	—	—	—	—	—	—	—	—	—	—
08	4	14.7	29.6	21.0	11.5	22.8	18.0	7.7	16.7	15.2	—	—	—	—	—	—	—	—	—	—	—	—	—	—	—	—	—	—	—	—	—
	6	9.1	27.1	19.9	7.0	20.7	17.0	4.8	15.6	14.4	—	11.6	34.7	22.9	9.3	27.7	19.9	7.1	21.0	17.1	—	—	—	—	—	—	—	—	—	—	—
	8	6.1	24.4	18.7	4.6	18.5	15.9	3.4	14.0	13.1	—	8.1	32.3	21.8	6.3	25.2	18.9	4.8	19.0	16.2	—	—	—	—	—	—	—	—	—	—	—
	10	4.4	21.6	17.																											



**AIR DELIVERY (CFM) — 60 Hz MOTOR
42DA**

UNIT SIZE	ROWS	FAN SPEED	EXTERNAL STATIC PRESSURE (in. wg)									
			0.0	0.05	0.10	0.15	0.20	0.25	0.30	0.40	0.50	0.60
06	3	HIGH	780	760	720	700	660	630	600	540	430	260
		MED	630	600	565	540	515	485	—	—	—	—
		LOW	530	505	475	450	—	—	—	—	—	—
	4	HIGH	760	740	700	680	640	610	580	505	380	—
		MED	610	580	545	520	495	—	—	—	—	—
		LOW	515	490	460	435	—	—	—	—	—	—
	6	HIGH	740	720	680	660	620	590	560	470	330	—
		MED	595	565	530	505	—	—	—	—	—	—
		LOW	505	480	450	—	—	—	—	—	—	—
08	3	HIGH	1060	1010	990	955	920	890	850	770	680	540
		MED	870	840	815	785	755	—	—	—	—	—
		LOW	630	600	565	540	—	—	—	—	—	—
	4	HIGH	1035	985	965	930	895	865	825	740	635	495
		MED	850	820	795	765	735	—	—	—	—	—
		LOW	615	585	550	525	—	—	—	—	—	—
	6	HIGH	1010	970	940	915	870	840	800	710	590	—
		MED	830	800	775	745	715	—	—	—	—	—
		LOW	600	570	535	510	—	—	—	—	—	—
10	3	HIGH	1250	1240	1230	1220	1210	1160	1100	970	840	700
		MED	1020	1010	1000	990	980	920	—	—	—	—
		LOW	805	790	780	765	—	—	—	—	—	—
	4	HIGH	1220	1210	1200	1190	1180	1130	1070	940	810	—
		MED	995	985	975	965	955	910	—	—	—	—
		LOW	785	770	760	745	—	—	—	—	—	—
	6	HIGH	1190	1180	1170	1160	1140	1090	1030	890	720	—
		MED	975	965	955	945	935	—	—	—	—	—
		LOW	765	750	740	725	—	—	—	—	—	—
12	3	HIGH	1420	1375	1330	1285	1240	1200	1150	1060	950	790
		MED	1100	1055	1010	965	920	—	—	—	—	—
		LOW	925	880	835	790	—	—	—	—	—	—
	4	HIGH	1390	1345	1300	1255	1210	1170	1120	1030	920	760
		MED	1080	1035	990	945	900	—	—	—	—	—
		LOW	905	860	815	770	—	—	—	—	—	—
	6	HIGH	1360	1315	1270	1225	1180	1130	1090	990	850	—
		MED	1055	1010	965	920	—	—	—	—	—	—
		LOW	885	840	795	—	—	—	—	—	—	—
14	3	HIGH	1810	1740	1680	1620	1550	1490	1420	1270	1110	890
		MED	1355	1275	1215	1145	1075	—	—	—	—	—
		LOW	860	790	720	650	—	—	—	—	—	—
	4	HIGH	1770	1700	1640	1580	1510	1450	1380	1230	1060	—
		MED	1330	1255	1195	1125	1055	—	—	—	—	—
		LOW	840	770	700	630	—	—	—	—	—	—
	6	HIGH	1730	1660	1590	1540	1450	1380	1310	1170	970	—
		MED	1300	1225	1165	1095	1025	—	—	—	—	—
		LOW	820	750	680	610	—	—	—	—	—	—
16	3	HIGH	2030	1960	1890	1820	1750	1680	1610	1460	1280	1000
		MED	1385	1315	1245	1175	1105	1035	—	—	—	—
		LOW	875	805	745	665	—	—	—	—	—	—
	4	HIGH	1995	1925	1855	1785	1715	1645	1575	1425	1245	965
		MED	1360	1290	1220	1150	980	1010	—	—	—	—
		LOW	860	790	730	650	—	—	—	—	—	—
	6	HIGH	1960	1890	1810	1750	1660	1590	1510	1350	1110	—
		MED	1335	1265	1195	1125	955	—	—	—	—	—
		LOW	845	775	715	635	—	—	—	—	—	—
18	3	HIGH	2230	2160	2090	2045	1950	1880	1810	1670	1500	1210
		MED	1860	1790	1720	1665	1585	1510	—	—	—	—
		LOW	1430	1360	1290	1225	—	—	—	—	—	—
	4	HIGH	2170	2100	2030	1985	1890	1820	1750	1610	1440	1150
		MED	1810	1740	1670	1615	1535	1460	—	—	—	—
		LOW	1390	1320	1250	1185	—	—	—	—	—	—
	6	HIGH	2110	2045	1980	1915	1850	1790	1720	1560	1320	—
		MED	1760	1690	1620	1565	1485	1410	—	—	—	—
		LOW	1355	1275	1205	1140	—	—	—	—	—	—
20	3	HIGH	2230	2170	2120	2065	2010	1950	1900	1780	1600	1300
		MED	1840	1785	1730	1675	1620	1555	—	—	—	—
		LOW	1405	1350	1295	1240	1185	—	—	—	—	—
	4	HIGH	2205	2145	2095	2040	1985	1925	—	—	—	—
		MED	1820	1765	1710	1655	1600	1535	—	—	—	—
		LOW	1390	1335	1280	1225	1170	—	—	—	—	—
	6	HIGH	2180	2120	2060	2015	1940	1880	1820	1670	1430	—
		MED	1800	1745	1690	1635	—	—	—	—	—	—
		LOW	1375	1320	1265	1210	—	—	—	—	—	—

42D Series Units

Performance data (cont)



AIR DELIVERY (CFM) — 60 Hz MOTOR (cont) 42DC,DD, AND DE

UNIT SIZE	ROWS	FAN SPEED	EXTERNAL STATIC PRESSURE (in. wg)									
			0.0	0.05	0.10	0.15	0.20	0.25	0.30	0.40	0.50	0.60
06	3	HIGH	760	725	690	650	620	580	550	470	380	230
		MED	610	575	545	505	470	—	—	—	—	—
		LOW	520	485	450	415	—	—	—	—	—	—
	4	HIGH	735	700	665	625	595	555	525	445	355	—
		MED	590	555	525	480	455	—	—	—	—	—
		LOW	505	470	435	400	—	—	—	—	—	—
	6	HIGH	710	675	640	600	570	540	500	410	280	—
		MED	570	535	505	460	435	—	—	—	—	—
		LOW	485	455	420	385	—	—	—	—	—	—
08	3	HIGH	970	935	900	845	830	790	760	670	550	350
		MED	795	760	725	685	635	—	—	—	—	—
		LOW	575	540	505	465	—	—	—	—	—	—
	4	HIGH	955	915	885	830	815	775	735	655	525	—
		MED	785	750	715	675	625	—	—	—	—	—
		LOW	570	535	500	460	—	—	—	—	—	—
	6	HIGH	940	900	860	815	780	740	700	590	430	—
		MED	770	735	700	660	610	—	—	—	—	—
		LOW	560	525	490	—	—	—	—	—	—	—
10	3	HIGH	1140	1125	1110	1090	1070	1010	960	860	760	660
		MED	930	915	900	880	860	—	—	—	—	—
		LOW	735	725	710	690	670	—	—	—	—	—
	4	HIGH	1105	1090	1070	1055	1030	975	925	825	725	625
		MED	905	890	875	855	835	—	—	—	—	—
		LOW	715	705	690	670	—	—	—	—	—	—
	6	HIGH	1070	1055	1030	1020	990	930	880	760	620	—
		MED	875	860	845	825	—	—	—	—	—	—
		LOW	690	680	665	645	—	—	—	—	—	—
12	3	HIGH	1590	1525	1460	1375	1330	1270	1200	1070	920	700
		MED	1235	1200	1125	1040	995	935	—	—	—	—
		LOW	1035	1000	925	840	—	—	—	—	—	—
	4	HIGH	1535	1470	1405	1320	1275	1215	1145	1015	865	—
		MED	1190	1125	1060	975	930	—	—	—	—	—
		LOW	1000	935	870	785	—	—	—	—	—	—
	6	HIGH	1480	1420	1360	1300	1240	1180	1120	980	780	—
		MED	1145	1085	1025	965	905	—	—	—	—	—
		LOW	965	905	845	785	—	—	—	—	—	—
14	3	HIGH	1740	1685	1620	1565	1500	1400	1380	1240	1050	—
		MED	1305	1250	1185	1130	1065	—	—	—	—	—
		LOW	825	770	705	650	—	—	—	—	—	—
	4	HIGH	1700	1645	1580	1525	1460	1360	1340	1200	1010	—
		MED	1275	1220	1155	1100	1035	—	—	—	—	—
		LOW	805	750	685	620	—	—	—	—	—	—
	6	HIGH	1660	1605	1540	1485	1420	1360	1300	1120	830	—
		MED	1245	1190	1125	1070	1005	—	—	—	—	—
		LOW	790	735	670	605	—	—	—	—	—	—
16	3	HIGH	1930	1865	1800	1735	1670	1600	1540	1400	1200	—
		MED	1315	1250	1185	1115	1055	—	—	—	—	—
		LOW	835	760	705	640	—	—	—	—	—	—
	4	HIGH	1895	1830	1765	1700	1635	1565	1505	1365	1165	—
		MED	1285	1220	1155	1085	1025	—	—	—	—	—
		LOW	815	740	685	620	—	—	—	—	—	—
	6	HIGH	1840	1775	1710	1645	1580	1520	1450	1280	970	—
		MED	1255	1190	1125	1055	995	—	—	—	—	—
		LOW	795	720	665	600	—	—	—	—	—	—
18	3	HIGH	2030	1965	1900	1835	1770	1710	1640	1480	1300	—
		MED	1695	1630	1565	1500	1435	1375	—	—	—	—
		LOW	1300	1235	1170	1105	1040	—	—	—	—	—
	4	HIGH	1995	1920	1865	1800	1735	1675	1605	1445	1265	—
		MED	1665	1600	1535	1470	1405	1345	—	—	—	—
		LOW	1280	1215	1150	1085	1020	—	—	—	—	—
	6	HIGH	1960	1885	1820	1765	1680	1610	1540	1370	1110	—
		MED	1635	1570	1505	1440	1375	—	—	—	—	—
		LOW	1255	1190	1125	1060	—	—	—	—	—	—
20	3	HIGH	2220	2150	2070	1995	1920	1850	1770	1620	1440	—
		MED	1830	1760	1690	1620	1550	1480	—	—	—	—
		LOW	1400	1330	1260	1190	1120	—	—	—	—	—
	4	HIGH	2170	2100	2020	1945	1870	1800	1720	1565	1355	—
		MED	1790	1720	1650	1580	1510	—	—	—	—	—
		LOW	1370	1300	1230	1160	—	—	—	—	—	—
	6	HIGH	2120	2050	1970	1895	1820	1750	1670	1510	1270	—
		MED	1750	1680	1610	1540	1470	—	—	—	—	—
		LOW	1340	1270	1200	1130	—	—	—	—	—	—

42D Series Units



AIR DELIVERY (CFM) — 60 Hz MOTOR (cont)
42DF

UNIT SIZE	ROWS	FAN SPEED	EXTERNAL STATIC PRESSURE (in. wg)					
			0.0	0.05	0.10	0.15	0.20	0.25
06	4	HIGH	670	655	640	615	580	530
		MED	540	520	495	450	—	—
		LOW	460	430	390	—	—	—
	5	HIGH	660	640	620	590	550	—
		MED	530	500	470	—	—	—
		LOW	450	420	360	—	—	—
	6	HIGH	650	625	600	565	520	450
		MED	520	490	450	—	—	—
		LOW	445	405	345	—	—	—
08	4	HIGH	810	790	770	745	720	690
		MED	665	640	610	580	—	—
		LOW	480	440	390	—	—	—
	5	HIGH	795	775	755	730	700	660
		MED	650	625	595	560	—	—
		LOW	470	425	365	—	—	—
	6	HIGH	780	760	740	715	680	630
		MED	640	615	580	540	—	—
		LOW	465	415	345	—	—	—
10	4	HIGH	1000	965	930	890	850	800
		MED	820	775	730	675	545	—
		LOW	645	585	525	—	—	—
	5	HIGH	980	940	905	860	815	755
		MED	800	755	705	640	550	—
		LOW	630	565	495	—	—	—
	6	HIGH	960	920	880	835	780	710
		MED	785	740	685	615	—	—
		LOW	620	550	470	—	—	—
12	4	HIGH	1220	1195	1170	1135	1100	1050
		MED	945	895	845	790	—	—
		LOW	795	730	665	—	—	—
	5	HIGH	1205	1175	1145	1105	1065	1005
		MED	935	880	825	765	—	—
		LOW	785	715	645	—	—	—
	6	HIGH	1190	1155	1120	1080	1030	960
		MED	925	865	805	—	—	—
		LOW	775	700	625	—	—	—
14	4	HIGH	1450	1410	1370	1320	1270	1200
		MED	1090	1035	970	880	—	—
		LOW	680	585	—	—	—	—
	5	HIGH	1425	1385	1340	1285	1225	1045
		MED	1070	1010	745	—	—	—
		LOW	675	565	—	—	—	—
	6	HIGH	1400	1355	1310	1250	1180	1090
		MED	1050	990	915	—	—	—
		LOW	665	545	—	—	—	—
16	4	HIGH	1570	1525	1480	1430	1380	1310
		MED	1070	1000	930	—	—	—
		LOW	680	560	—	—	—	—
	5	HIGH	1540	1495	1450	1385	1265	—
		MED	1050	975	900	—	—	—
		LOW	665	540	—	—	—	—
	6	HIGH	1510	1465	1420	1360	1290	1200
		MED	1030	950	865	—	—	—
		LOW	650	500	—	—	—	—
18	4	HIGH	1780	1725	1670	1610	1540	1450
		MED	1485	1415	1345	1260	—	—
		LOW	1140	1050	940	—	—	—
	5	HIGH	1740	1685	1630	1560	1480	1380
		MED	1455	1380	1300	1210	—	—
		LOW	1115	1020	905	—	—	—
	6	HIGH	1700	1650	1590	1515	1420	1310
		MED	1420	1345	1260	1165	—	—
		LOW	1090	990	855	—	—	—
20	4	HIGH	2000	1955	1910	1850	1780	1700
		MED	1650	1605	1545	1460	1360	—
		LOW	1260	1190	1080	—	—	—
	5	HIGH	1990	1930	1870	1800	1720	1625
		MED	1625	1560	1475	1375	1235	—
		LOW	1245	1155	1020	—	—	—
	6	HIGH	1940	1890	1830	1760	1670	1550
		MED	1600	1525	1435	1325	1140	—
		LOW	1222	1130	970	—	—	—

42D Series Units

Performance data (cont)



42D SERIES COOLING CAPACITY CORRECTION FACTORS

ACTUAL CFM	UNIT SIZE															
	06		08		10		12		14		16		18		20	
	TH	SH	TH	SH	TH	SH	TH	SH	TH	SH	TH	SH	TH	SH	TH	SH
100	—	—	—	—	—	—	—	—	—	—	—	—	—	—	—	—
125	—	—	—	—	—	—	—	—	—	—	—	—	—	—	—	—
150	—	—	—	—	—	—	—	—	—	—	—	—	—	—	—	—
175	—	—	—	—	—	—	—	—	—	—	—	—	—	—	—	—
200	0.46	0.41	—	—	—	—	—	—	—	—	—	—	—	—	—	—
225	0.51	0.45	—	—	—	—	—	—	—	—	—	—	—	—	—	—
250	0.55	0.49	—	—	—	—	—	—	—	—	—	—	—	—	—	—
275	0.58	0.53	0.47	0.42	—	—	—	—	—	—	—	—	—	—	—	—
300	0.62	0.57	0.51	0.45	0.43	0.38	—	—	—	—	—	—	—	—	—	—
350	0.69	0.65	0.57	0.50	0.48	0.46	—	—	—	—	—	—	—	—	—	—
400	0.76	0.73	0.62	0.57	0.53	0.47	0.46	0.41	—	—	—	—	—	—	—	—
450	0.82	0.80	0.67	0.63	0.58	0.52	0.51	0.45	—	—	—	—	—	—	—	—
500	0.89	0.87	0.72	0.69	0.62	0.57	0.55	0.47	—	—	—	—	—	—	—	—
550	0.95	0.94	0.77	0.74	0.66	0.62	0.58	0.53	0.57	0.47	—	—	—	—	—	—
600	1.00	1.00	0.82	0.80	0.70	0.67	0.62	0.57	0.58	0.53	—	—	—	—	—	—
700	1.11	1.12	0.92	0.91	0.78	0.76	0.69	0.65	0.62	0.57	0.57	0.50	—	—	—	—
800	1.18	1.22	1.00	1.00	0.86	0.85	0.76	0.73	0.68	0.64	0.62	0.57	0.57	0.51	—	—
900	—	—	1.08	1.08	0.94	0.93	0.82	0.80	0.74	0.71	0.67	0.63	0.62	0.57	0.58	0.52
1000	—	—	1.16	1.18	1.00	1.00	0.89	0.87	0.82	0.80	0.72	0.69	0.68	0.65	0.62	0.57
1200	—	—	—	—	1.13	1.14	1.00	1.00	0.90	0.89	0.82	0.80	0.76	0.72	0.70	0.67
1400	—	—	—	—	—	—	1.11	1.12	1.00	1.00	0.92	0.91	0.84	0.82	0.78	0.76
1600	—	—	—	—	—	—	1.18	1.22	1.10	1.11	1.00	1.00	0.93	0.92	0.86	0.85
1800	—	—	—	—	—	—	—	—	—	—	1.08	1.08	1.00	1.00	0.94	0.93
2000	—	—	—	—	—	—	—	—	—	—	1.16	1.18	1.07	1.07	1.00	1.00
2200	—	—	—	—	—	—	—	—	—	—	—	—	—	—	1.07	1.07
2400	—	—	—	—	—	—	—	—	—	—	—	—	—	—	1.13	1.14

LEGEND

SH — Sensible Heat
 TH — Total Heat

NOTE: Use Sensible Heat correction factors when calculating heating capacity.

42D Series Units



DIRECT-EXPANSION (DX) COIL COOLING CAPACITIES* (MBtuh)

UNIT SIZE	SAT. SUCT TEMP (F)	4 ROW								6 ROW							
		Entering Air Temperature (F) — db/wb															
		76/63		78/65		80/67		82/69		76/63		78/65		80/67		82/69	
		TH	SH	TH	SH	TH	SH	TH	SH	TH	SH	TH	SH	TH	SH	TH	SH
06	35	21.0	15.8	23.1	16.4	25.3	17.0	27.5	17.5	26.0	18.9	23.3	19.5	30.8	20.0	33.4	20.5
	40	17.1	14.0	19.2	14.7	21.5	15.3	23.8	15.9	22.0	17.0	24.5	17.7	27.0	18.4	29.7	19.0
	45	13.2	12.2	15.1	12.9	17.2	13.5	19.5	14.1	17.6	15.0	20.0	15.7	22.6	16.5	25.3	17.2
	50	9.8	9.8	11.3	11.0	12.9	11.7	14.9	12.3	13.3	12.9	15.3	13.7	17.7	14.4	20.3	15.2
08	35	27.5	20.9	30.0	21.6	32.5	22.1	35.1	22.6	32.8	24.3	35.7	25.0	38.8	25.7	41.9	26.3
	40	23.1	18.9	25.8	19.6	28.4	20.3	31.1	20.9	28.0	22.1	31.1	22.9	34.2	23.7	37.3	24.4
	45	18.3	16.7	20.8	17.5	23.6	18.3	26.4	19.0	22.5	19.5	25.5	20.5	28.7	21.4	32.0	22.2
	50	13.8	13.8	15.9	15.2	18.2	16.0	20.8	16.8	17.1	16.8	19.6	17.8	22.5	18.8	25.8	19.7
10	35	32.2	25.2	34.9	25.7	37.7	26.3	40.4	26.7	38.2	29.0	41.2	29.7	44.3	30.3	47.3	30.8
	40	27.7	23.0	30.6	23.8	33.5	24.5	36.4	25.1	33.3	26.7	36.5	27.6	39.9	28.4	43.2	29.1
	45	22.4	20.6	25.3	21.5	28.3	22.3	31.5	23.1	27.4	24.1	30.7	25.1	34.2	26.0	37.9	26.9
	50	17.4	17.4	19.7	18.9	22.5	19.9	25.5	20.8	21.3	21.0	24.2	22.2	27.6	23.2	31.3	24.3
12	35	36.9	29.3	40.0	30.0	43.1	30.6	46.2	31.2	42.8	33.5	45.8	34.0	49.1	34.6	52.2	35.0
	40	31.6	26.9	34.9	27.8	38.3	28.6	41.7	29.3	37.9	31.2	41.3	32.1	44.8	32.8	48.2	33.4
	45	25.7	24.1	28.9	25.1	32.2	26.1	35.9	27.0	31.9	28.5	35.5	29.5	39.2	30.4	43.0	31.3
	50	20.0	20.0	22.6	22.1	25.5	23.2	29.0	24.3	25.5	25.2	28.6	26.5	32.4	27.6	36.3	28.7
14	35	41.1	33.4	44.4	34.1	47.6	34.6	50.6	35.1	63.0	45.2	68.7	46.7	75.1	48.2	81.4	49.5
	40	35.9	31.0	39.3	31.9	42.8	32.6	46.3	33.3	53.3	40.6	59.3	42.3	65.4	43.9	72.1	45.4
	45	29.8	28.0	33.2	29.2	36.8	30.2	40.6	31.1	42.5	35.6	48.4	31.4	54.7	39.2	61.2	40.9
	50	23.7	23.7	26.5	25.9	29.8	27.2	33.6	28.3	31.8	30.5	36.8	32.4	42.7	34.2	49.1	36.1
16	35	58.4	43.4	64.1	44.9	70.0	46.3	75.9	47.7	69.4	50.7	76.0	52.2	82.7	53.6	89.4	54.9
	40	48.3	38.6	54.1	40.3	60.1	41.9	66.3	43.4	59.9	45.9	66.3	47.7	72.8	49.3	79.9	50.9
	45	37.5	33.7	42.8	35.4	48.9	37.2	55.2	38.9	48.5	40.6	54.9	42.6	61.7	44.5	68.7	46.3
	50	27.7	27.7	32.1	30.5	37.0	32.3	42.8	34.0	36.6	35.1	42.3	37.2	48.9	39.2	55.9	41.1
18	35	65.1	48.6	71.2	50.1	77.4	51.6	83.7	52.9	80.1	57.7	89.5	59.7	95.8	61.5	103.9	63.2
	40	54.5	43.6	60.8	45.4	67.2	47.0	73.8	48.6	67.5	51.7	75.2	53.9	83.1	56.0	91.7	58.0
	45	42.8	38.2	48.8	40.2	55.4	42.0	62.2	43.8	53.4	45.2	61.0	47.6	69.1	49.9	77.5	52.1
	50	31.8	31.8	36.9	34.7	42.5	36.7	49.0	38.6	39.9	38.7	46.1	41.0	53.5	43.4	61.6	45.8
20	35	70.7	53.1	77.0	54.7	83.5	56.1	90.1	57.5	87.0	63.1	94.8	65.1	103.2	67.0	111.7	68.6
	40	59.6	48.0	66.3	49.8	73.1	51.5	80.0	53.1	73.9	56.9	83.1	59.2	90.4	61.4	99.3	63.4
	45	47.3	42.3	53.8	44.4	60.8	46.7	68.0	48.2	59.1	50.1	67.2	52.6	75.9	55.0	84.7	57.3
	50	35.5	35.5	41.0	38.6	47.2	40.7	54.2	42.8	44.5	43.1	51.3	45.6	59.3	48.2	68.1	50.7

42D Series Units

LEGEND
db — Dry Bulb
TH — Total Heat
SH — Sensible Heat
wb — Wet Bulb

*Capacity based on R-22. For refrigerants other than R-22 consult factory. Ratings at nominal cfm. All DX units to operate at high speed only.

DX — CFM CORRECTION FACTORS

% OF NOMINAL CFM	CORRECTION FACTOR	
	Total	Sensible
80	0.95	0.93
90	0.97	0.96
100	1.00	1.00
110	1.02	1.04
120	1.05	1.08

NOTE: Consult factory for values outside of table.
 DX Total Capacity (MBtuh) =
 Base TH x Total Correction Factor
 DX Sensible Capacity (MBtuh) =
 Base SH x Sensible Correction Factor

$$\% \text{ of Nominal Cfm} = \frac{\text{Actual Cfm}}{\text{Nominal Cfm}} \text{ (from Air Delivery tables)}$$

42D HOT WATER CAPACITY CORRECTION FACTORS

ENTERING AIR TEMPERATURE (F)	ENTERING WATER TEMPERATURE (F)										
	100	110	120	130	140	150	160	170	180	190	200
50	0.455	0.545	0.636	0.727	0.818	0.909	1.000	1.091	1.182	1.273	1.364
55	0.409	0.500	0.591	0.682	0.773	0.864	0.955	1.045	1.136	1.227	1.318
60	0.363	0.455	0.545	0.636	0.727	0.818	0.909	1.000	1.091	1.182	1.273
65	0.318	0.409	0.500	0.591	0.682	0.773	0.864	0.955	1.045	1.136	1.227
70	0.272	0.363	0.455	0.545	0.636	0.727	0.818	0.909	1.000	1.091	1.182
75	0.227	0.318	0.409	0.500	0.591	0.682	0.773	0.864	0.955	1.045	1.136
80	0.182	0.272	0.363	0.455	0.545	0.636	0.727	0.818	0.909	1.000	1.091

NOTE: Hot Water Heating Capacity (MBtuh) = Base Capacity x Hot Water Capacity Correction Factor x SH (SH value found in Cooling Capacity Correction Factors table on page 84).

Performance data (cont)



42D HOT WATER HEATING CAPACITIES (MBtuh)

ROWS	UNIT SIZE	GPM														
		0.5	1.0	1.5	2.0	2.5	3.0	3.5	4.0	5.0	6.0	7.0	8.0	9.0	10.0	11.0
1 ROW	06	13.5	17.5	19.5	20.5	21.3	21.8	22.2	22.5	—	—	—	—	—	—	—
	08	16.0	22.0	24.6	26.5	27.9	29.0	29.5	29.9	—	—	—	—	—	—	—
	10	—	25.5	29.0	31.2	32.7	34.0	34.8	35.5	—	—	—	—	—	—	—
	12	—	29.0	33.6	36.3	38.2	39.8	40.9	41.7	—	—	—	—	—	—	—
	14	—	31.5	37.7	41.0	43.5	45.5	46.8	48.0	—	—	—	—	—	—	—
	16	—	34.0	41.2	45.3	48.4	51.0	52.8	54.2	—	—	—	—	—	—	—
	18	—	36.0	44.5	49.6	53.1	55.9	58.0	59.7	—	—	—	—	—	—	—
	20	—	38.0	47.5	52.9	56.9	60.3	62.8	64.7	—	—	—	—	—	—	—
2 ROW	06	—	24.5	—	30.7	—	33.5	—	35.2	36.0	—	—	—	—	—	—
	08	—	29.5	—	38.7	—	42.9	—	45.3	46.5	—	—	—	—	—	—
	10	—	33.5	—	45.4	—	50.7	—	54.4	56.7	68.2	69.3	—	—	—	—
	12	—	36.5	—	51.5	—	59.0	—	63.3	66.2	68.7	70.2	71.2	—	—	—
	14	—	39.3	—	56.8	—	66.2	—	71.9	75.7	78.4	80.5	82.0	—	—	—
	16	—	41.0	—	61.9	—	73.5	—	80.2	84.8	87.9	90.3	92.3	—	—	—
	18	—	—	—	66.5	—	79.6	—	87.9	93.3	97.2	100.0	102.3	—	—	—
	20	—	—	—	70.0	—	84.5	—	93.6	100.5	105.2	108.7	111.4	—	—	—
4 ROW	06	—	—	—	40.2	—	45.0	—	47.9	49.5	50.8	51.5	—	—	—	—
	08	—	—	—	47.8	—	56.7	—	60.9	63.5	65.5	67.4	—	—	—	—
	10	—	—	—	57.3	—	66.4	—	72.3	76.6	79.5	81.5	83.0	84.4	—	—
	12	—	—	—	64.0	—	76.4	—	83.7	88.8	92.2	95.3	97.7	99.4	—	—
	14	—	—	—	—	—	82.9	—	92.0	98.3	103.0	106.6	109.5	112.0	—	—
	16	—	—	—	—	—	89.4	—	100.5	109.3	115.2	119.4	122.7	125.8	—	—
	18	—	—	—	—	—	95.7	—	109.0	109.3	126.1	131.2	135.2	138.6	—	—
	20	—	—	—	—	—	101.3	—	116.2	128.1	136.2	142.3	145.9	151.0	—	—
6 ROW	06	—	—	—	—	—	—	—	54.6	56.5	57.7	58.6	59.4	60.0	—	—
	08	—	—	—	—	—	—	—	68.9	72.2	74.5	76.3	77.6	78.5	—	—
	10	—	—	—	—	—	—	—	81.9	86.3	89.6	92.2	94.1	95.5	96.7	97.7
	12	—	—	—	—	—	—	—	94.0	99.8	104.0	107.3	110.4	112.4	114.1	115.4
	14	—	—	—	—	—	—	—	102.4	111.0	116.8	121.0	124.2	126.9	129.5	131.5
	16	—	—	—	—	—	—	—	111.6	122.3	129.4	134.5	138.6	142.0	145.2	147.5
	18	—	—	—	—	—	—	—	119.5	133.0	141.2	147.2	152.2	156.3	160.3	163.4
	20	—	—	—	—	—	—	—	128.0	142.3	152.1	158.0	164.7	169.6	174.0	177.5

NOTE: Ratings based on nominal cfm, 70 F EDB (entering dry bulb), 180 F EWT (entering water temperature).

42D STEAM COIL HEATING CAPACITIES (Btuh)

UNIT SIZE	70 F ENTERING AIR TEMPERATURE	
	1-Row Coil	2-Row Coil
06	28,900	52,500
08	38,400	70,000
10	46,000	86,000
12	55,800	103,900
14	65,100	121,200
16	74,400	138,500
18	83,700	155,800
20	92,100	172,000

STEAM PRESSURE CORRECTION FACTORS

EAT (F)	STEAM PRESSURE (PSIG)		
	2	5	10
40	1.202	1.265	1.353
50	1.134	1.196	1.279
60	1.067	1.125	1.208
70	1.000	1.054	1.128

NOTE: Steam Heating Capacity (Btuh) =
Base Capacity x Pressure Correction Factor x SH
(SH value found in Cooling Capacity Correction Factors table on page 84.)

NOTES:

1. Ratings based on nominal cfm, 70 F entering dry bulb, 2 psig steam.
2. All capacities above 50,000 Btuh rating are beyond the capacity of the standard control valve. Consult factory for these applications.

Cv FACTOR BY COIL AND UNIT SIZE

COIL TYPE 42DA,DC,DD,DE,DF	UNIT SIZE							
	06	08	10	12	14	16	18	20
1 Row — Heat Only	1.4	1.3	1.2	1.2	1.1	1.1	1.0	1.0
2 Row — Heat Only	2.5	2.4	2.3	2.2	2.1	2.0	2.0	1.9
3 Row — Heat or Cool	2.1	2.0	3.6	3.3	4.7	4.6	4.7	4.6
4 Row — Heat or Cool	4.0	3.9	4.6	4.5	7.6	7.4	7.2	7.0
6 Row — Heat or Cool	4.3	4.1	3.9	3.7	6.5	6.3	6.1	5.9

Electrical data



42D ELECTRIC HEATER DATA

HEATER VOLTAGE	HEATER kW										
	2.0	3.0	4.0	5.0	6.0	7.0	8.0	9.0	10.0	12.0	14.0
	FLA										
120	16.7	25.0	—	—	—	—	—	—	—	—	—
208	9.6	14.4	19.2	24.0	28.8	33.7	38.5	43.3	48.1	57.7	67.3
240	8.3	12.5	16.7	20.8	25.0	29.2	33.3	37.5	41.7	50.0	58.3
277	7.2	10.8	14.4	18.0	21.7	25.3	28.9	32.5	36.1	43.3	50.5

LEGEND

FLA — Full Load Amps

NOTES:

1. All heaters are single-stage and single-phase.
2. In all units using over 48 amps, the heating elements are subdivided and protected. Additional cost is incurred because of added components.
3. A separate power source is required for motor and heaters except when motors and heaters of same voltage are ordered in conjunction with a single power source wiring option. This option, which meets NEC requirements, consists of a factory-furnished and installed junction box and fuse for 6.25 amp (max) fan and control circuit connection to a single power source. Power supply circuit to unit must be field furnished and installed in accordance with applicable codes.

UL Listing

The UL Listing signifies that Carrier's fan coil units have been examined by UL and comply with the organization's applicable standards. The Canadian Standards Association (CSA) and Underwriters' Laboratories of Canada also approve the fan coil units.



42D Series Units

Electrical data (cont)



42DA MOTOR DATA

VOLTS/PH-Hz	FAN SPEED	FAN SPEED (RPM)	UNIT SIZE											
			06			08			10			12*		
			Nominal Hp	Watts	Amps	Nominal Hp	Watts	Amps	Nominal Hp	Watts	Amps	Nominal Hp	Watts	Amps
115-1-60	H	1200		280	2.70		330	3.10		470	5.60		550	5.30
	M	980	1/10	200	2.00	1/8	225	2.25	1/5	360	3.70	1/10 (2)	305	2.92
	L	790		140	1.50		135	1.44		240	2.60		205	1.93
208/230-1-60	H	1200		240	1.10		420	1.80		430	2.00		450	2.10
	M	980	1/10	175	0.74	1/8	280	1.26	1/5	260	1.20	1/10 (2)	325	1.45
	L	790		110	0.50		155	0.73		165	0.80		215	1.00
277-1-60	H	1200		275	1.15		275	1.21		425	1.62		550	2.40
	M	980	1/10	175	0.69	1/8	175	0.69	1/5	260	1.04	1/5 (2)	355	1.38
	L	790		90	0.33		90	0.34		155	0.65		175	0.67

VOLTS/PH-Hz	FAN SPEED	FAN SPEED (RPM)	UNIT SIZE											
			14*			16*			18*			20*		
			Nominal Hp	Watts	Amps	Nominal Hp	Watts	Amps	Nominal Hp	Watts	Amps	Nominal Hp	Watts	Amps
115-1-60	H	1200		650	6.40		900	8.80		1180	11.80		1180	11.80
	M	980	1/10 (2)	440	4.60	1/5 (2)	705	6.90	1/5 (2)	770	8.30	1/4 (2)	770	8.30
	L	790		280	3.00		430	4.20		460	5.30		460	5.30
208/230-1-60	H	1200		465	2.10		740	3.60		925	4.10		925	4.10
	M	980	1/10 (2)	325	1.45	1/5 (2)	360	1.80	1/5 (2)	5.45	2.48	1/4 (2)	545	2.48
	L	790		220	1.00		220	1.20		330	1.60		330	1.60
277-1-60	H	1200		735	2.70		940	3.60		980	3.72		980	3.72
	M	980	1/10 (2)	510	1.90	1/5 (2)	560	2.20	1/5 (2)	550	2.20	1/4 (2)	550	2.20
	L	790		330	1.30		335	1.40		320	1.40		320	1.40

*Total motor amps and watts shown for units with 2 motors (size 12 through 20).

NOTE: Motor nameplate amps may vary.

42DC,DD AND DE MOTOR DATA

VOLTS/PH-Hz	FAN SPEED	FAN SPEED (RPM)	UNIT SIZE											
			06			08			10			12*		
			Nominal Hp	Watts	Amps	Nominal Hp	Watts	Amps	Nominal Hp	Watts	Amps	Nominal Hp	Watts	Amps
115-1-60	H	1200		265	2.60		310	3.00		440	4.50		550	5.40
	M	980	1/10	195	1.95	1/8	220	2.30	1/5	330	3.40	1/10 (2)	390	3.90
	L	790		155	1.54		140	1.50		225	2.50		305	3.10
208/230-1-60	H	1200		235	1.00		325	1.45		410	1.80		700	3.20
	M	980	1/10	165	0.72	1/8	210	0.95	1/5	250	1.10	1/10 (2)	430	2.00
	L	790		110	0.49		135	0.62		160	0.76		305	1.48
277-1-60	H	1200		275	1.10		275	1.40		395	1.51		535	2.40
	M	980	1/10	175	0.70	1/8	175	0.69	1/5	260	1.10	1/10 (2)	360	1.40
	L	790		90	0.33		90	0.34		155	0.65		190	0.70

VOLTS/PH-Hz	FAN SPEED	FAN SPEED (RPM)	UNIT SIZE											
			14*			16*			18*			20*		
			Nominal Hp	Watts	Amps	Nominal Hp	Watts	Amps	Nominal Hp	Watts	Amps	Nominal Hp	Watts	Amps
115-1-60	H	1200		690	6.80		900	9.80		1015	10.20		1020	10.20
	M	980	1/10 (2)	560	5.40	1/5 (2)	725	7.70	1/5 (2)	745	7.80	1/5 (2)	750	7.80
	L	790		280	3.50		450	5.24		450	5.30		460	5.30
208/230-1-60	H	1200		720	3.30		680	3.00		820	3.70		820	3.70
	M	980	1/10 (2)	440	2.00	1/5 (2)	445	2.00	1/5 (2)	500	2.20	1/4 (2)	510	2.20
	L	790		310	1.48		285	1.33		330	1.50		330	1.50
277-1-60	H	1200		700	2.65		830	3.20		900	3.50		925	3.52
	M	980	1/10 (2)	495	1.96	1/5 (2)	510	2.00	1/5 (2)	550	2.23	1/4 (2)	550	2.23
	L	790		300	1.30		300	1.30		320	1.36		320	1.36

*Total motor amps and watts shown for units with 2 motors (size 12 through 20).

NOTE: Motor nameplate amps may vary.

42D Series Units



42DF MOTOR DATA

VOLTS/PH-Hz	FAN SPEED	FAN SPEED (RPM)	UNIT SIZE											
			06			08			10			12*		
			Nominal Hp	Watts	Amps	Nominal Hp	Watts	Amps	Nominal Hp	Watts	Amps	Nominal Hp	Watts	Amps
115-1-60	H	1200		260	2.40		275	3.10		380	3.70		490	4.40
	M	980	1/10	195	1.70	1/8	205	2.10	1/5	300	3.00	1/10 (2)	310	3.00
	L	790		125	1.15		155	1.58		210	2.00		210	2.10
208/230-1-60	H	1200		235	1.00		230	1.05		410	1.80		450	2.00
	M	980	1/10	165	0.72	1/8	145	0.65	1/4	220	1.05	1/10 (2)	300	1.40
	L	790		105	0.48		105	0.48		160	0.75		224	1.05
277-1-60	H	1200		205	0.72		270	0.90		285	1.27		370	1.44
	M	980	1/10	140	0.51	1/10	190	0.71	1/5	180	0.73	1/10 (2)	235	0.89
	L	790		90	0.31		155	0.57		95	0.37		165	0.63

VOLTS/PH-Hz	FAN SPEED	FAN SPEED (RPM)	UNIT SIZE											
			14*			16*			18*			20*		
			Nominal Hp	Watts	Amps	Nominal Hp	Watts	Amps	Nominal Hp	Watts	Amps	Nominal Hp	Watts	Amps
115-1-60	H	1200		520	5.00		670	6.50		800	7.40		840	8.20
	M	980	1/10 (2)	320	3.00	1/5 (2)	470	4.80	1/5 (2)	670	6.60	1/5 (2)	685	6.60
	L	790		210	2.10		300	3.10		420	4.10		435	4.20
208/230-1-60	H	1200		470	2.10		590	2.90		705	3.20		810	3.44
	M	980	1/10 (2)	340	1.50	1/5 (2)	440	2.10	1/5 (2)	420	2.00	1/4 (2)	495	2.20
	L	790		230	1.10		300	1.45		315	1.55		320	1.50
277-1-60	H	1200		450	1.60		470	1.70		620	2.80		870	3.30
	M	980	1/10 (2)	330	1.28	1/5 (2)	350	1.20	1/5 (2)	420	1.65	1/4 (2)	545	2.20
	L	790		250	0.90		250	0.90		230	0.95		320	1.36

*Total motor amps and watts shown for units with 2 motors (size 12 through 20).
NOTE: Motor nameplate amps may vary.

Model number nomenclature

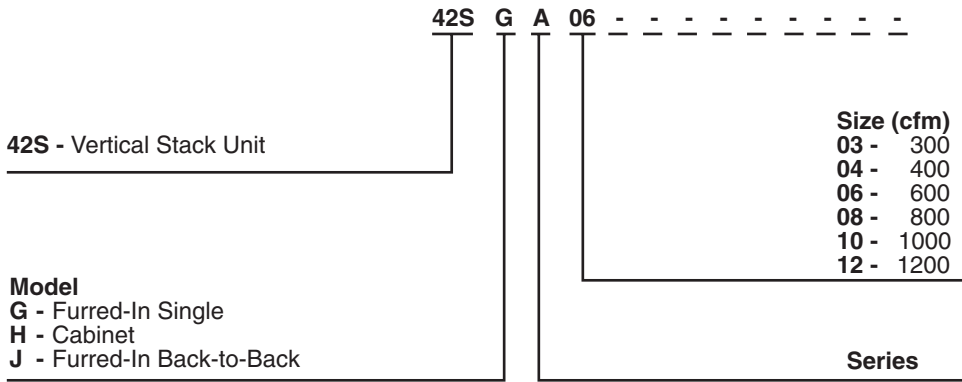

ARI capacity ratings

The 42S series fan coil units are certified in compliance with the Air Conditioning and Refrigeration Institute (ARI) Industry Standard 440-98 for room fan coil units. Approved standard ratings are tabulated below:



ARI APPROVED STANDARD RATINGS — STANDARD CAPACITY COIL

UNIT TYPE*	UNIT SIZE COIL	NOMINAL CFM	GPM	COOLING CAPACITY		POWER INPUT (WATTS)†
				Total Heat Btuh	Sensible Heat Btuh	
42S	03	300	2.4	11,500	7,000	85
	04	400	2.9	13,600	9,000	115
	06	600	4.5	21,900	14,000	135
	08	800	5.5	27,500	17,800	210
	10	1000	7.7	37,700	24,500	290
	12	1200	8.1	43,100	28,400	380

ARI APPROVED STANDARD RATINGS — HIGH-CAPACITY COIL

UNIT TYPE*	UNIT SIZE COIL	NOMINAL CFM	GPM	COOLING CAPACITY		POWER INPUT (WATTS)†
				Total Heat Btuh	Sensible Heat Btuh	
42S	03	300	2.6	12,200	7,300	85
	04	400	3.3	15,600	9,600	115
	06	600	5.5	26,000	15,300	135
	08	800	6.4	31,400	19,500	210
	10	1000	8.7	42,200	25,600	290
	12	1200	9.5	49,400	31,300	380

*Table values are listed for each half of 42SJ units and master/slave.
 †Motor type, permanent split capacitor, operating at 115-1-60 voltage.

NOTE: Ratings based on motor at high fan speed, standard air and dry coil operation, 10 degrees F water temperature rise; entering air temperatures of 80 F db, 67 F wb; entering water temperature 45 F.

42S Series Units

Sound data



SOUND PRESSURE DATA 42S SOUND RATINGS — OCTAVE BAND SOUND POWER LEVEL RATINGS* (db)

SIZE	NOMINAL CFM	SPEED	RPM	CENTER FREQUENCY — Hz						
				125	250	500	1000	2000	4000	8000
03	300	High	1075	64.5	57	52.5	49	41	39	35.5
		Medium	825	61.5	51.5	48.5	43.5	33.5	30.5	24.5
		Low	675	56	45.5	42.5	35.5	25.5	21	—
04	400	High	1075	69	59.5	55.5	50.5	41.5	39.5	36.5
		Medium	850	64	52.5	48.5	43.5	33.5	30.5	24.5
		Low	650	57.5	46.5	42.5	35.5	25.5	21	—
06	600	High	1075	71.5	60.5	57	52.5	44.5	42	39
		Medium	900	67.5	55.5	51	46.5	37	34.5	28.5
		Low	700	61	49	45	40	30	26	—
08	800	High	1075	74	62	58.5	54	48.5	44	41
		Medium	900	71	57.5	54	49.5	42	38.5	33.5
		Low	675	65	51.5	48.5	43	34.5	29.5	21
10	1000	High	1075	77	66.5	61.5	59	53	49.5	46
		Medium	900	74	64	58.5	55	48.5	46	41
		Low	700	67	59	55	51	45	40.5	35.5
12	1200	High	1075	79	70	65.5	62	56.5	51.5	47.5
		Medium	925	76.5	66	62.5	58	52	47	42.5
		Low	775	70.5	62.5	59	54	47.5	41.5	37

*Testing per ARI Standard 350-86.

Physical data and dimensions

UNIT SIZE 42S	03	04	06	08	10	12
NOMINAL AIRFLOW (cfm)	300	400	600	800	1000	1200
SHIPPING WEIGHT (lb)*						
42SG	225	225	250	250	275	275
42SH	225	225	250	250	275	275
42SJ	420	420	470	470	520	520
COIL WATER WEIGHT (Approx lb per row of coil) 42S Series	1.6	1.6	2.3	2.3	3.1	3.1
COILS FPI	14 fins/inch					
MOTOR (qty)						
42SG,SH	1	1	1	1	1	1
42SJ	2	2	2	2	2	2
BLOWER (qty)						
42SG,SH	1	1	1	1	1	1
42SJ	2	2	2	2	2	2
FILTERS Nominal Size (in.) (1-in. thick) 42SG,SH,SJ Qty	12 ¹ / ₂ x 24 ¹ / ₄		16 ¹ / ₄ x 26 ³ / ₄ 1†		20 ¹ / ₂ x 29 ¹ / ₄	
PIPING CONNECTIONS Inlet (in. OD)	1/2					

*Calculate Operating Weight of unit: Shipping Weight + Coil Water Weight x Number of Coil Rows.

†42SJ units require two filters.

Physical data and dimensions (cont)



42SG FURRED-IN STACK

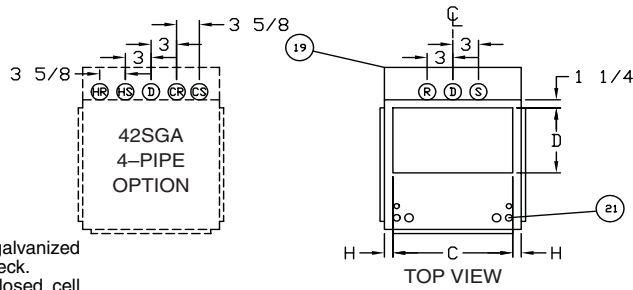

NOTES:

1. Units are fabricated of 18-gage galvanized steel with a 16-gage galvanized fan deck.
2. All risers are insulated with 1/2-in. closed cell insulation.
3. Thermostats shipped loose for field connection.
4. Risers are piped to coil with valves as specified.
5. Blower, motor, valves, coil, and filter are accessible through the return air opening.
6. Unit and control box are insulated with 1/2-in. coated fiberglass insulation.
7. Riser length = [(floor to floor) + 2 in.], maximum riser length = 115 inches.
8. Maximum riser size is 2 1/2-in. diameter. If larger sizes are required, please consult the factory.
9. Expansion loops in hot water heating circuits as required.
10. A 9-in. x 2 1/4-in. slot is provided in the inside back panel for coil connection penetration to permit expansion and contraction of risers. Care must be taken to position the risers so that coil connection is at center of slot.
11. Drawing is pictorial (see unit arrangements for actual supply and return air orientation).
12. All dimensions are in inches.

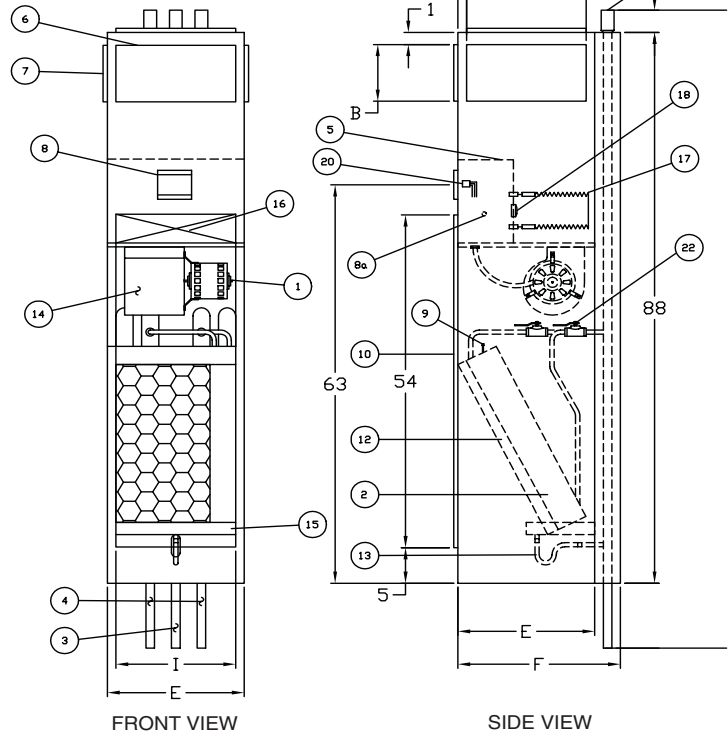

ITEM	DESCRIPTION	QTY
1	Motor, 3-Speed, PSC, with Quick Connect	1
2	Coil 1/2-in. OD Copper Tube	1
3	Riser, Drain (Copper)	1
4	Riser, Supply and Return (Copper)	2/4
5	Control Box	1
6	Supply Air Opening(s)	
7	Duct Collar, 1/2-in. Extension (Typical)	
8	Control Opening (Surface Mount Stat)	1
8a	Knockout (For Optional Remote Mounting)	2
9	Air Vent, Manual	1
10	Return Air Opening	1
11	3-in. Expanded Section	3/5
12	Filter, Throwaway, 1-in.*	1
13	Flexible Drain Tube/P-Trap	1
14	Blower	1
15	Drain Pan	1
16	Access Panel (Control Box)	1
17	Strip Heater (Optional)	1
18	Limit Switch*† (Optional)	1
19	Riser Chase	1
20	Molex Connector for Field Installed Stat	1
21	Electrical Knockouts	1
22	1/2-in. Isolation Ball Valves*	2/4

*Factory-Installed.
†Field-Installed.

42S Series Units

UNIT	SINGLE SUPPLY			DOUBLE SUPPLY			TOP SUPPLY			DIMENSIONS (in.)				
	A	B	Size	A	B	Size	C	D	Size	E	F	G	H	I
42SGA03	14	8	14 x 8	14	6	14 x 6	14	10	14 x 10	17	22 ³ / ₈	1 1/2	1 1/2	14
42SGA04	14	12	14 x 12	14	6	14 x 6	14	10	14 x 10	17	22 ³ / ₈	1 1/2	1 1/2	14
42SGA06	18	10	18 x 10	18	6	18 x 6	16	12	16 x 12	20	25 ³ / ₈	1	2	18
42SGA08	18	12	18 x 12	18	6	18 x 6	16	12	16 x 12	20	25 ³ / ₈	1	2	18
42SGA10	—	—	—	22	8	22 x 8	18	16	18 x 16	24	29 ³ / ₈	1	3	22
42SGA12	—	—	—	22	8	22 x 8	18	16	18 x 16	24	29 ³ / ₈	1	3	22

42SH CABINET

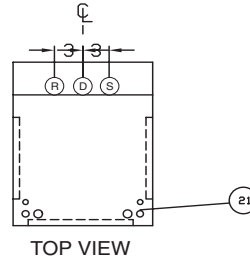
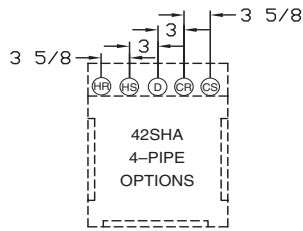

NOTES:

1. Units are fabricated of 18-gage galvanized steel with a 16-gage galvanized fan deck, painted with Arctic White.
2. 3 speed switch and thermostat are unit mounted.
3. Risers are piped to coil with valves as specified.
4. Blower, motor, valves, coil, and filter are accessible through the return air opening.
5. Unit is insulated with coated fiberglass.
6. Control box is insulated with 1/2-in. insulation for unit mounted controls.
7. Riser length = [(floor to floor) +2 in.], maximum riser length = 115 inches.
8. Maximum riser size is 2 1/2-in. diameter. If larger sizes are required, please consult the factory.
9. Expansion loops in hot water heating circuits as required.
10. A 9-in. x 2 1/4-in. slot is provided in the inside back panel for coil connection penetration to permit expansion and contraction of risers. Care must be taken to position the risers so that coil connection is at center of slot.
11. Drawing is pictorial (see unit arrangements for actual supply and return air orientation).
12. 42SHA available in front return only.
13. All dimensions are in inches.

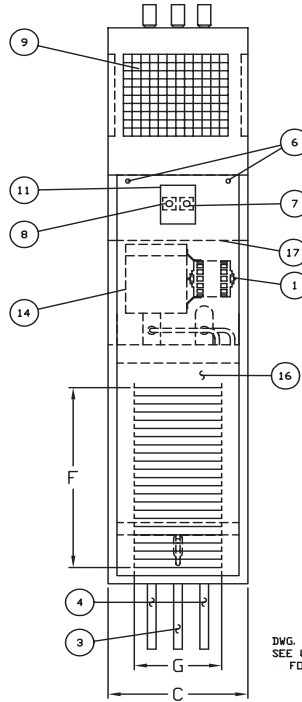

FRONT VIEW

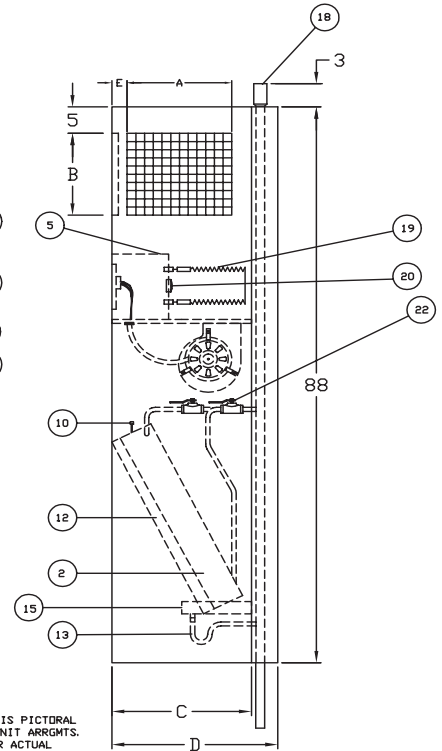

SIDE VIEW

DWG. IS PICTORIAL
SEE UNIT ARRGMTS.
FOR ACTUAL

ITEM	DESCRIPTION	QTY
1	Motor, 3-Speed, PSC Series "L"	
2	Coil 1/2-in. OD Tube	1
3	Riser, Drain (Type "M" Copper)	1
4	Riser, Supply and Return (Type "M" Copper)	2/4
5	Control Box	1
6	Cabinet Camlocks	
7	3 Speed Switch	
8	T-Stat	1
9	D.D. Steel Core Grille Assembly	1
10	Air Vent, Manual	1
11	Hinged Control Access Door	1
12	Filter, Throwaway, 1-in.*	1
13	Flexible Drain Tube/P-Trap	1
14	Blower	1
15	Drain Pan	1
16	Return Air Panel	1
17	Electrical Access Panel	1
18	3-in. Expansion Section	3/5
19	Strip Heater (Optional)	1
20	Limit Switch*† (Optional)	1
21	Electrical Knockouts	1
22	1/2-in. Isolation Ball Valves*	2/4

*Factory-Installed.
†Field-Installed.

UNIT	SINGLE SUPPLY			DOUBLE SUPPLY			TOP SUPPLY		DIMENSIONS (in.)		
	A	B	Size	A	B	Size	C	D	E	F	G
42SHA03	14	8	14 x 8	14	6	14 x 6	17	22 ³ / ₈	1 1/2	22 ¹ / ₈	14 ³ / ₄
42SHA04	14	12	14 x 12	14	8	14 x 8	17	22 ³ / ₈	1 1/2	22 ¹ / ₈	14 ³ / ₄
42SHA06	14	12	14 x 12	14	8	14 x 8	20	25 ³ / ₈	2	26 ⁵ / ₈	17 ³ / ₄
42SHA08	14	16	14 x 16	14	10	14 x 10	20	25 ³ / ₈	2	26 ⁵ / ₈	17 ³ / ₄
42SHA10	18	16	18 x 16	14	12	14 x 12	24	29 ³ / ₈	3	31 ¹ / ₈	17 ³ / ₄
42SHA12	18	16	18 x 16	14	12	14 x 12	24	29 ³ / ₈	3	31 ¹ / ₈	17 ³ / ₄

42S Series Units

Physical data and dimensions (cont)



42SJ BACK-TO-BACK FURRED-IN STACK

NOTES:

1. Units are fabricated of 18-gage galvanized steel with a 16-gage galvanized fan deck.
2. All risers are insulated with 1/2-in. closed cell insulation.
3. Thermostats shipped loose for field connection.
4. Risers are piped to coil with valves as specified.
5. Blower, motor, valves, coil, and filter are accessible through the return air opening.
6. Unit and control box are insulated with 1/2-in. coated fiberglass insulation.
7. Riser length = [(floor to floor) + 2 in.], maximum riser length = 115 inches.
8. Maximum riser size is 2 1/2-in. diameter. If larger sizes are required, please consult the factory.
9. Expansion loops in hot water heating circuits as required.
10. A 9-in. x 2 1/4-in. slot is provided in the inside back panel for coil connection penetration to permit expansion and contraction of risers. Care must be taken to position the risers so that coil connection is at center of slot.
11. Drawing is pictorial (see unit arrangements for actual supply and return air orientation).
12. All dimensions are in inches.

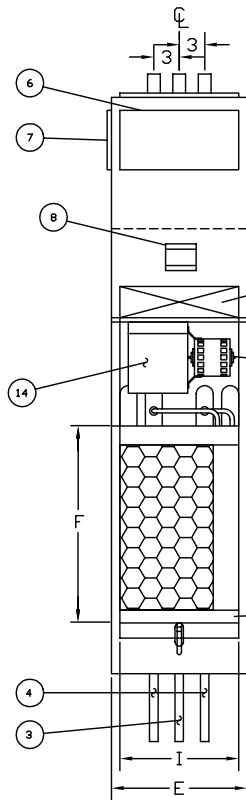
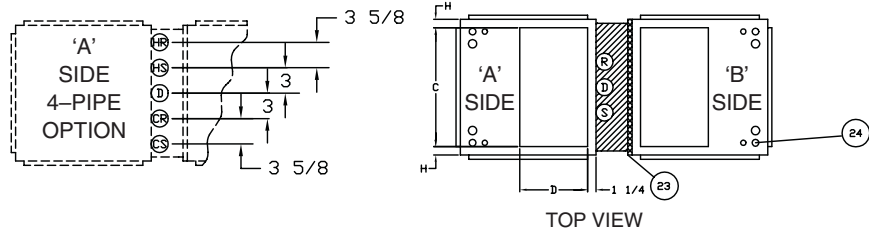

FRONT VIEW

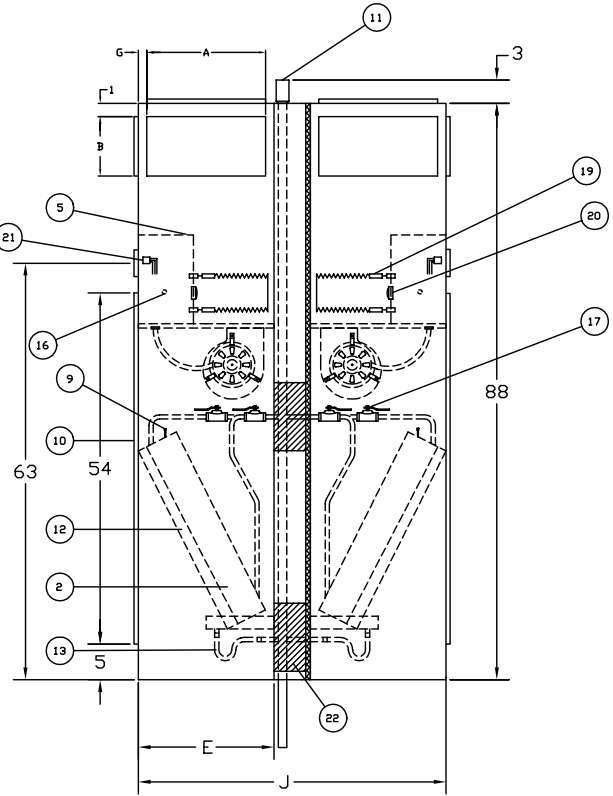

SIDE VIEW

ITEM	DESCRIPTION	QTY
1	Motor, 3-Speed, PSC, w/Quick Connect	2
2	Coil 1/2-in. OD Copper Tube	2
3	Riser, Drain (Copper)	1
4	Riser, Supply and Return (Copper)	2/4
5	Control Box	2
6	Supply Air Opening(s)	
7	Duct Collar, 1/2-in. Extension (Typical)	
8	Control Opening (Surface Mount Stat)	2
9	Air Vent, Manual	2
10	Return Air Opening	2
11	3-in. Expanded Section	3/5
12	Filter, Throwaway, 1-in.*	2

ITEM	DESCRIPTION	QTY
13	Flexible Drain Tube/P-Trap	2
14	Blower	2
15	Drain Pan	2
16	Knockout (For Optional Remote Mounting)	2
17	1/2-in. Isolation Ball Valves*	4/8
18	Access Panel (Control Box)	2
19	Strip Heater* (Optional)	2
20	Limit Switch*† (Optional)	2
21	Molex Connector for Field Installed Stat	2
22	Thermafiber Insulation	
23	Gypsum Board, 5/8-in. Type "X"	1
24	Electrical Knockouts	

*Factory-Installed.
†Field-Installed.

UNIT	SINGLE SUPPLY			DOUBLE SUPPLY			TOP SUPPLY			DIMENSIONS (in.)					
	A	B	Size	A	B	Size	C	D	Size	E	F	G	H	I	J
42SJA03	14	8	14 x 8	14	6	14 x 6	14	10	14 x 10	17	22 ³ / ₈	1 1/2	1 1/2	14	39 ⁵ / ₈
42SJA04	14	12	14 x 12	14	6	14 x 6	14	10	14 x 10	17	22 ³ / ₈	1 1/2	1 1/2	14	39 ⁵ / ₈
42SJA06	18	10	18 x 10	18	6	18 x 6	16	12	16 x 12	20	25 ³ / ₈	1	2	18	45 ⁵ / ₈
42SJA08	18	12	18 x 12	18	6	18 x 6	16	12	16 x 12	20	25 ³ / ₈	1	2	18	45 ⁵ / ₈
42SJA10	—	—	—	22	8	22 x 8	18	16	18 x 16	24	29 ³ / ₈	1	3	22	53 ⁵ / ₈
42SJA12	—	—	—	22	8	22 x 8	18	16	18 x 16	24	29 ³ / ₈	1	3	22	53 ⁵ / ₈

42S Series Units

Accessory dimensions



PANEL NO. 1

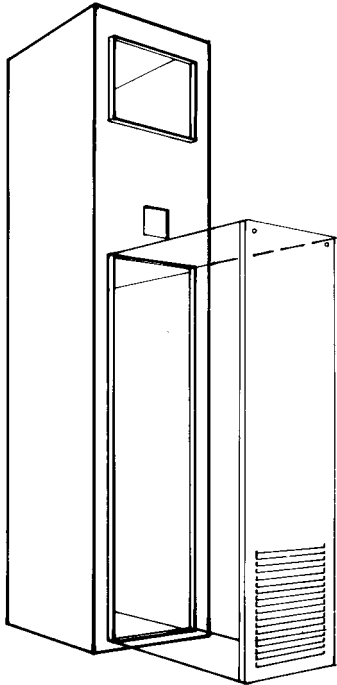

SHORT FRAME — SURFACE MOUNTED GRILLE

PANEL NO. 2

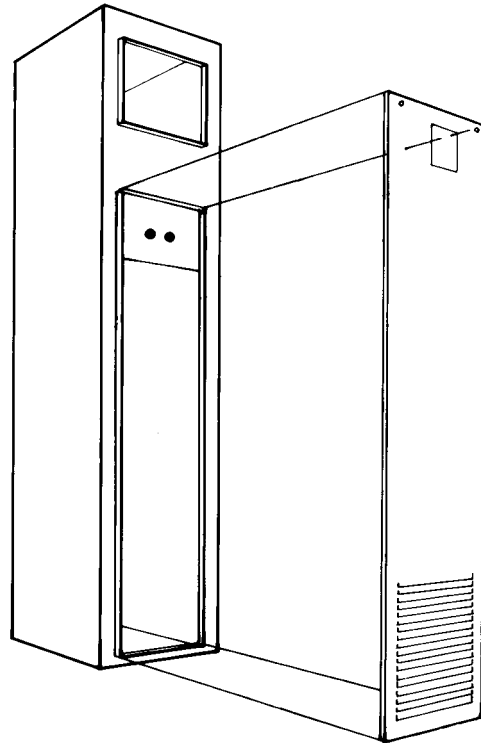

LONG FRAME — SURFACE MOUNTED GRILLE

PANEL NO. 3

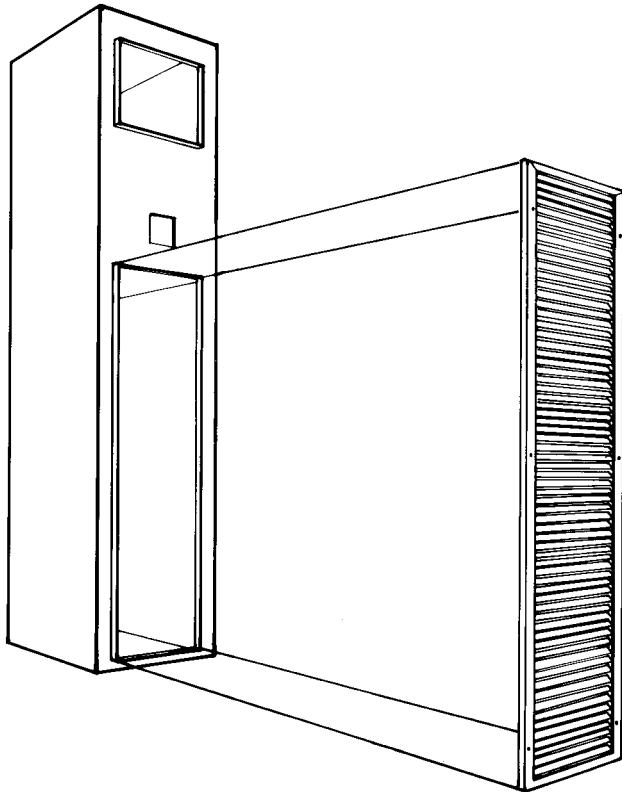

SHORT FRAME — SURFACE MOUNTED GRILLE

GRILLE LOCATIONS

UNIT	FIG.	GRILLE	ARRANGEMENTS
42SG	A	Supply	Up to 3 grilles located on any of 3 sides shown.
		Return	One grille located on any of 3 sides shown.
42SH	B	Supply	Up to 3 grilles located on any of 3 sides shown.
		Return	One grille located opposite risers.
42SJ	C	Supply	Up to 3 grilles located on any of 3 sides shown (per section).
		Return	One grille located on any of 3 sides shown (per section).

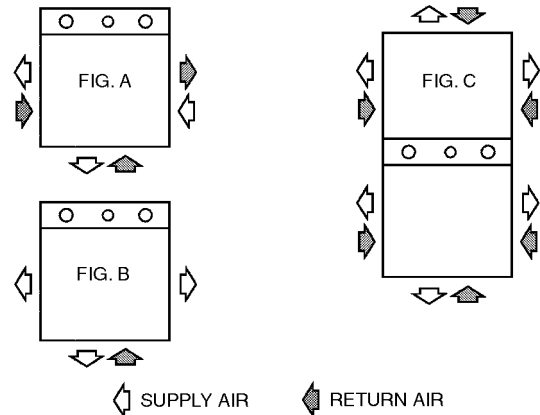

42S Series Units

Accessory dimensions (cont)



PANEL NO. 4

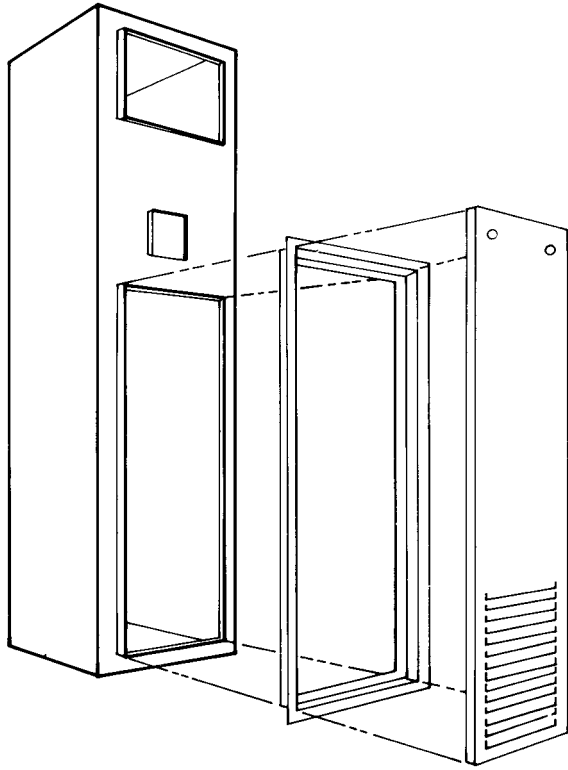

SHORT FRAME — FLUSH MOUNTED GRILLE

PANEL NO. 5

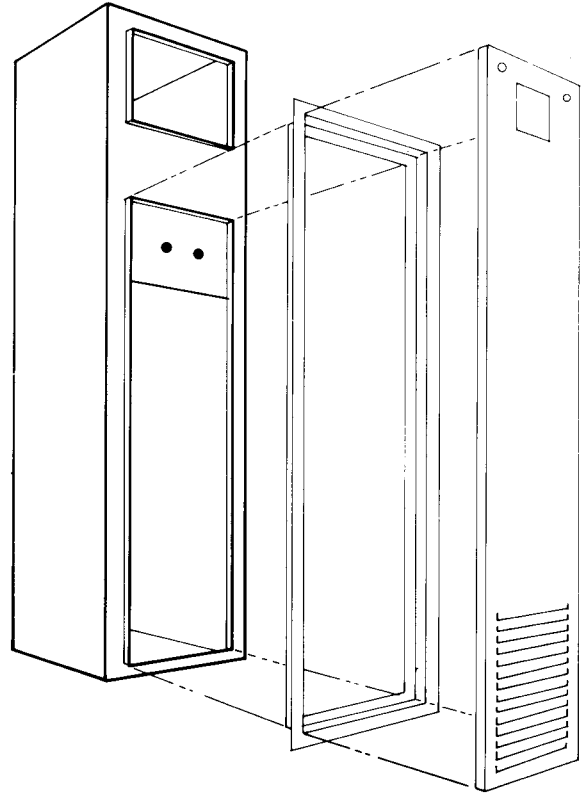

LONG FRAME — FLUSH MOUNTED GRILLE

RETURN-AIR WALL PANELS FOR FURRED-IN UNITS

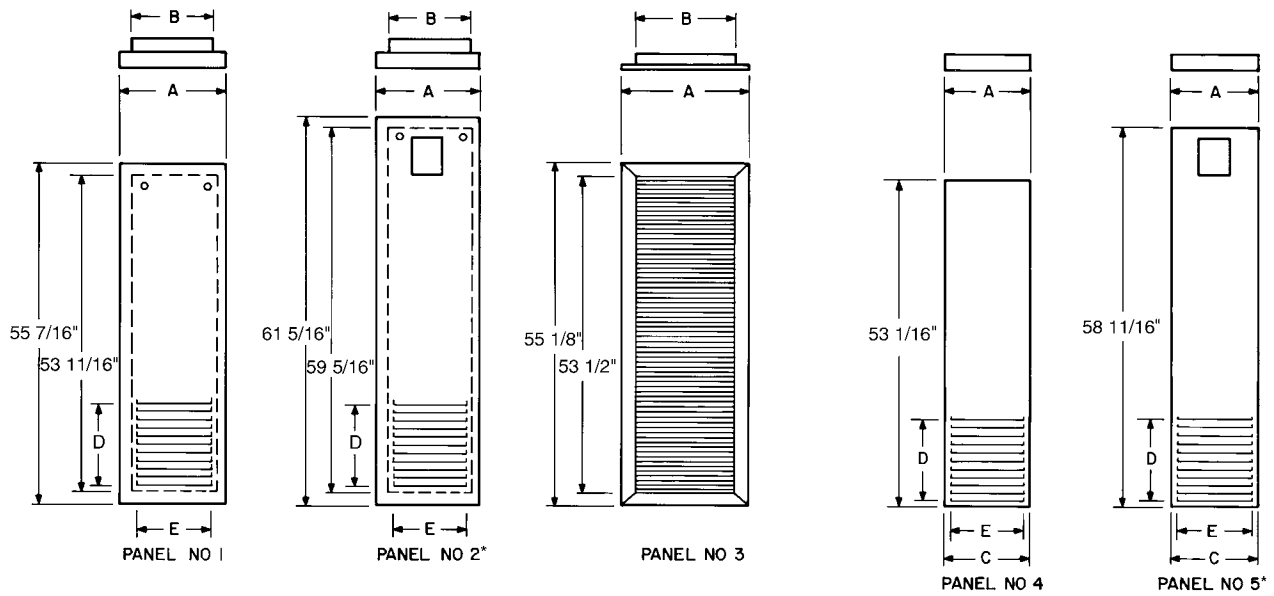

PANELS-NO FRAME

PANELS-WITH FRAME

Panel and Frame Dimensions (in.)

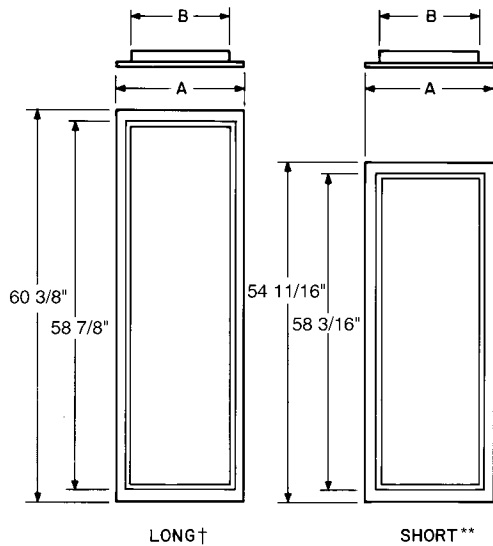

FRAMES

PANEL NO.	UNIT SIZE	A	B	C	D	E
1	03, 04	15 ⁷ / ₁₆	13 ¹ / ₂	—	22 ¹ / ₂	12 ³ / ₁₆
	06, 08	19 ⁷ / ₁₆	17 ¹ / ₂	—	26 ⁵ / ₈	14 ³ / ₄
	10, 12	23 ⁷ / ₁₆	21 ¹ / ₂	—	31 ¹ / ₁₆	17 ³ / ₄
2	03, 04	15 ⁷ / ₁₆	13 ¹ / ₂	—	22 ¹ / ₂	12 ³ / ₁₆
	06, 08	19 ⁷ / ₁₆	17 ¹ / ₂	—	26 ⁵ / ₈	14 ³ / ₄
	10, 12	23 ⁷ / ₁₆	21 ¹ / ₂	—	31 ¹ / ₁₆	17 ³ / ₄
3	03, 04	15	13 ¹ / ₂	—	—	—
	06, 08	19	17 ¹ / ₂	—	—	—
	10, 12	23	21 ¹ / ₂	—	—	—
4	03, 04	13 ³ / ₈	—	13 ³ / ₈	22 ¹ / ₂	12 ³ / ₁₆
	06, 08	17 ³ / ₈	—	17 ³ / ₈	26 ⁵ / ₈	14 ³ / ₄
	10, 12	21 ³ / ₈	—	21 ³ / ₈	31 ¹ / ₁₆	17 ³ / ₄
5	03, 04	13 ³ / ₈	—	13 ³ / ₈	22 ¹ / ₂	12 ³ / ₁₆
	06, 08	17 ³ / ₈	—	17 ³ / ₈	26 ⁵ / ₈	14 ³ / ₄
	10, 12	21 ³ / ₈	—	21 ³ / ₈	31 ¹ / ₁₆	17 ³ / ₄
LONG FRAME	03, 04	15 ¹ / ₈	13 ¹ / ₂	—	—	—
	06, 08	19 ¹ / ₈	17 ¹ / ₂	—	—	—
	10, 12	23 ¹ / ₈	21 ¹ / ₂	—	—	—
SHORT FRAME	03, 04	15 ¹ / ₈	13 ¹ / ₂	—	—	—
	06, 08	19 ¹ / ₈	17 ¹ / ₂	—	—	—
	10, 12	23 ¹ / ₈	21 ¹ / ₂	—	—	—

*Can be manufactured without door.

†For Frame 5.

**For Frame 4.

NOTE: Dimensions in inches. ±1/16 in. tolerances.

Performance data



AIR DELIVERY

UNIT	SIZE	COIL	CFM AT 0.0 ESP FOR FAN SPEED			HIGH SPEED CFM AT ESP INDICATED				
			Low	Med	High	0.05	0.10	0.15	0.20	0.25
42SG,SH,SJ	03	3 Row	260	300	440	410	380	340	300	240
	04		300	410	510	480	450	420	380	340
	06		490	570	710	670	630	590	540	480
	08		580	650	840	800	760	710	670	610
	10		640	960	1130	1100	1070	1040	1000	970
	12		750	940	1260	1230	1200	1160	1130	1090
	03	4 Row	250	290	420	390	350	320	280	220
	04		280	400	490	470	430	400	360	320
	06		480	560	590	560	520	480	430	380
	08		460	590	800	760	720	670	620	560
	10		630	940	1090	1060	1040	1010	980	950
	12		740	920	1250	1220	1180	1150	1110	1070

AIR DELIVERY WITH HIGH-STATIC FAN

UNIT	SIZE	COIL	High Speed CFM AT ESP INDICATED				
			0.2	0.25	0.3	0.4	0.5
42SG,SH,SJ	03	3 Row	505	485	465	420	370
		4 Row	485	465	445	400	350
		5 Row	465	445	425	380	330
	04	3 Row	530	510	485	440	400
		4 Row	510	490	465	420	380
		5 Row	490	470	445	400	360
	06	3 Row	860	820	790	720	660
		4 Row	840	800	770	700	640
		5 Row	820	780	750	680	620
	08	3 Row	1020	985	940	845	780
		4 Row	1000	965	920	825	760
		5 Row	980	945	900	805	740
	10	3 Row	1265	1235	1205	1140	1075
		4 Row	1245	1215	1185	1120	1055
		5 Row	1225	1195	1165	1100	1035
	12	3 Row	1320	1300	1290	1235	1160
		4 Row	1300	1280	1270	1215	1140
		5 Row	1280	1260	1250	1195	1120

LEGEND

ESP — External Static Pressure



42S COOLING CAPACITY (GPM) 3-ROW COIL

UNIT SIZE	GPM	75 F DB/63 F WB									80 F DB/67 F WB									85 F DB/71 F WB								
		40 F EWT			45 F EWT			50 F EWT			40 F EWT			45 F EWT			50 F EWT			40 F EWT			45 F EWT			50 F EWT		
		ΔT	TC _b	SC _b	ΔT	TC _b	SC _b	ΔT	TC _b	SC _b	ΔT	TC _b	SC _b	ΔT	TC _b	SC _b	ΔT	TC _b	SC _b	ΔT	TC _b	SC _b	ΔT	TC _b	SC _b	ΔT	TC _b	SC _b
03	1	16.4	8.2	6.7	13.5	6.8	6.0	10.9	5.4	5.2	19.5	9.8	7.4	16.5	8.2	6.7	13.6	6.8	6.0	22.9	11.4	8.0	19.7	9.9	7.4	16.6	8.3	6.7
	1.5	13.0	9.7	7.4	10.5	7.9	6.6	8.2	6.2	5.8	15.7	11.8	8.3	13.1	9.9	7.4	10.6	7.9	6.6	18.7	14.0	9.0	16.0	12.0	8.2	13.2	9.9	7.4
	2	10.8	10.8	7.9	8.6	8.6	6.9	6.6	6.0	13.1	13.1	8.8	10.8	10.8	7.8	8.6	8.6	6.9	15.5	15.5	9.6	13.2	13.2	8.7	10.9	10.9	7.8	
	2.5	9.1	11.4	8.2	7.3	9.1	7.2	5.5	6.9	6.2	11.1	13.9	9.2	9.2	11.6	8.2	7.3	9.2	7.2	13.3	16.6	10.1	11.3	14.2	9.1	9.3	11.7	8.1
04	1	18.0	9.0	7.8	15.1	7.5	7.0	12.3	6.2	6.0	21.3	10.6	8.6	18.2	9.1	7.8	15.2	7.6	7.0	24.8	12.4	9.3	21.5	10.7	8.6	18.3	9.1	7.9
	1.5	14.5	10.9	8.8	11.9	8.9	7.8	9.5	7.1	6.8	17.4	13.1	9.7	14.6	11.0	8.8	11.9	8.9	7.9	20.5	15.4	10.5	17.6	13.2	9.7	14.6	11.0	8.8
	2	12.2	12.2	9.4	9.8	9.8	8.3	7.6	7.6	7.2	14.6	14.6	10.4	12.2	12.2	9.3	9.8	9.8	8.3	17.4	17.4	11.3	14.8	14.8	10.3	12.2	12.2	9.3
	2.5	10.4	13.0	9.8	8.4	10.4	8.6	6.4	8.0	7.5	12.7	15.8	10.9	10.5	13.1	9.7	8.3	10.4	8.6	15.1	18.8	11.9	12.8	16.0	10.8	10.6	13.2	9.7
06	1	22.7	11.3	10.1	19.6	9.8	9.0	15.8	7.9	7.9	26.3	13.1	11.1	23.1	11.6	10.2	20.0	10.0	9.1	30.0	15.0	12.1	26.7	13.4	11.2	23.6	11.8	10.3
	1.5	18.6	13.9	11.8	15.9	11.9	10.7	13.3	10.0	9.3	21.7	16.3	13.0	18.9	14.2	11.9	16.2	12.2	10.8	25.1	18.8	14.0	22.1	16.6	13.1	19.2	14.4	12.0
	2	15.8	15.8	12.9	13.3	13.3	11.6	11.0	10.2	18.7	18.7	14.1	16.0	16.0	12.9	13.5	13.5	11.7	21.9	21.9	15.3	19.0	19.0	16.0	14.2	16.3	16.3	13.1
	3	12.3	18.5	14.2	10.2	15.2	12.7	8.1	12.2	11.2	14.9	22.3	15.7	12.5	18.8	14.2	10.2	15.4	12.8	17.6	26.3	17.1	15.1	22.7	15.6	12.7	19.0	14.2
08	1	24.0	12.0	11.0	20.7	10.3	9.7	16.7	8.4	8.4	27.8	13.9	12.3	24.5	12.2	11.1	20.4	10.2	10.2	31.7	15.8	13.4	28.3	14.2	12.4	25.0	12.5	11.3
	1.5	20.2	15.1	13.4	17.3	13.0	11.9	14.0	10.5	10.5	23.5	17.6	14.8	20.5	15.4	13.5	17.7	13.3	12.1	27.0	20.2	16.0	23.9	17.9	14.9	20.9	15.7	13.7
	2	17.3	17.3	14.8	14.7	14.7	13.3	12.3	12.3	11.5	20.4	20.4	16.3	17.6	17.6	15.0	15.0	15.0	15.0	23.6	23.6	17.6	20.7	20.7	16.4	17.9	17.9	15.1
	3	13.7	20.5	16.6	11.4	17.1	14.9	9.3	13.9	13.0	16.4	24.6	18.2	13.9	20.8	16.7	11.5	17.2	15.0	19.3	28.9	19.8	16.6	25.0	18.3	14.0	21.0	16.7
10	1.5	22.6	16.9	15.2	19.5	14.7	13.5	15.4	11.5	11.5	26.2	19.6	16.9	23.1	17.4	15.4	20.1	15.0	13.7	29.9	22.4	18.4	26.8	20.1	17.1	23.7	17.8	15.6
	2	19.9	19.9	17.4	17.2	17.2	15.5	13.5	13.5	13.5	23.1	23.1	19.2	20.3	20.3	17.6	17.6	17.6	17.6	26.6	26.6	20.8	23.7	23.7	19.4	20.8	20.8	17.8
	3	16.0	23.9	19.9	13.6	20.4	18.0	11.3	17.0	15.7	18.9	28.3	21.9	16.3	24.4	20.1	13.8	20.8	18.2	22.0	32.9	23.7	19.2	28.8	22.0	16.6	24.9	20.3
	4	13.5	26.9	21.5	11.2	22.4	19.3	9.2	18.4	16.9	16.1	32.2	23.6	13.7	27.4	21.6	11.4	22.8	19.5	18.9	37.8	25.7	16.4	32.8	23.7	13.9	27.8	21.7
12	1.5	23.3	17.4	16.0	19.1	14.3	14.3	15.8	11.9	11.9	27.0	20.3	17.9	23.3	17.9	16.2	19.3	14.5	14.5	30.8	23.1	19.6	27.7	20.7	18.1	24.4	18.3	16.4
	2	20.7	20.7	18.5	17.9	17.9	16.5	14.1	14.1	14.1	24.1	24.1	20.6	21.2	21.2	18.8	18.4	18.4	16.7	27.6	27.6	22.4	24.7	24.7	20.8	21.8	21.8	19.0
	3	16.9	25.3	21.7	14.4	21.6	19.5	12.0	18.1	16.8	19.8	29.7	23.9	17.2	25.8	21.9	14.7	22.1	19.7	23.0	34.5	25.8	20.2	30.3	24.1	17.6	26.4	22.2
	4	14.3	28.6	23.5	12.0	24.0	21.2	9.9	19.8	18.4	17.0	34.0	25.9	14.5	29.1	23.7	12.2	24.4	21.4	19.9	39.8	28.7	17.3	34.6	26.0	14.8	29.6	23.9
12	6	11.0	33.1	25.7	9.0	27.0	22.9	7.2	21.6	20.0	13.3	39.8	28.4	11.1	33.3	25.7	9.0	27.1	23.1	15.7	47.0	30.9	13.4	40.3	28.3	11.2	33.6	25.8

42S COOLING CAPACITY (GPM) 4-ROW COIL

UNIT SIZE	GPM	75 F DB/63 F WB									80 F DB/67 F WB									85 F DB/71 F WB								
		40 F EWT			45 F EWT			50 F EWT			40 F EWT			45 F EWT			50 F EWT			40 F EWT			45 F EWT			50 F EWT		
		ΔT	TC _b	SC _b	ΔT	TC _b	SC _b	ΔT	TC _b	SC _b	ΔT	TC _b	SC _b	ΔT	TC _b	SC _b	ΔT	TC _b	SC _b	ΔT	TC _b	SC _b	ΔT	TC _b	SC _b	ΔT	TC _b	SC _b
03	1	18.2	9.1	7.2	15.6	7.8	6.6	13.2	6.6	5.8	21.3	10.7	7.9	18.5	9.2	7.3	15.9	7.9	6.6	24.6	12.3	8.5	21.6	10.8	7.9	18.7	9.4	7.3
	1.5	14.3	10.7	8.0	11.9	8.9	7.2	9.8	7.3	6.4	17.1	12.8	8.8	14.5	10.9	8.0	12.1	9.1	7.2	20.0	15.0	9.6	17.4	13.0	8.8	14.8	11.1	8.0
	2	11.8	11.8	8.5	9.7	9.1	7.6	7.7	7.7	6.7	14.3	14.3	9.5	12.1	12.1	8.5	9.9	9.9	7.6	16.9	16.9	10.4	14.6	14.6	9.4	12.3	12.3	8.5
	2.5	10.1	12.6	8.9	8.3	10.3	7.9	6.5	8.1	6.8	12.3	15.3	9.9	10.3	12.9	8.9	8.4	10.5	7.9	14.6	18.2	10.9	12.6	15.8	9.9	10.6	13.2	8.8
04	1	20.2	10.1	8.5	17.4	8.7	7.6	14.8	7.4	6.7	23.4	11.7	9.2	20.5	10.3	8.5	17.8	8.9	7.7	26.9	13.4	10.0	23.8	11.9	9.3	21.0	10.5	8.6
	1.5	16.1	12.0	9.5	13.6	10.2	8.6	11.3	8.5	7.6	19.0	14.3	10.4	16.3	12.2	9.6	13.8	10.4	8.7	22.1	16.6	11.3	19.3	14.5	10.4	16.6	12.4	9.6
	2	13.5	13.5	10.2	11.2	11.2	9.2	9.1	9.1	8.1	16.1	16.1	11.3	13.7	13.7	10.2	11.3	11.3	9.2	19.0	19.0	12.2	16.4	16.4	11.2	13.9	13.9	10.2
	2.5	11.7	14.6	10.7	9.6	12.0	9.5	7.6	9.5	8.4	14.1	17.6	11.9	11.9	14.9	10.7	9.7	12.1	9.6	16.6	20.8	13.0	14.4	18.0	11.8	12.1	15.1	10.7
06	1	26.0	13.0	11.1	22.7	11.4	10.0	19.4	9.7	8.7	29.9	15.0	12.2	26.5	13.3	11.2	23.3	11.6	10.1	33.9	17.0	13.1	30.5	15.2	12.3	27.2	13.6	11.3
	1.5	18.2	18.2	14.3	15.5	15.5	13.0	13.0	13.0	11.5	21.5	21.5	15.7	18.5	18.5	14.4	15.8	15.8	13.1	25.0	25.0	16.9	21.8	21.8	15.7	18.8	18.8	14.4
	2	14.2	21.3	15.8	11.8	17.6	14.1	9.5	14.2	12.5	17.0	25.6	17.5	14.4	21.7	15.8	11.9	17.8	14.2	20.1	30.1	19.1	17.4	26.1	17.4	14.6	21.9	15.8
	3	11.7	23.3	16.8	9.5	18.9	14.8	7.4	14.9	12.9	14.0	28.1	18.6	11.8	23.6	16.6	9.5	19.1	14.8	16.6	33.2	20.3	14.3	28.6	18.4	11.9	23.8	16.5
08	1	27.5	13.7	12.2	23.8	11.9	10.8	18.9	9.4	9.4	31.7	15.8	13.5	28.0	14.0	12.3	24.3	12.2	10.9	35.9	17.9	14.6	32.3	16.1	13.6	28.6	14.3	12.4
	1.5	20.2	20.2	16.7	17.3	17.3	15.1	14.6	14.6	13.2	23.6	23.6	18.3	20.5	16.8	17.7	17.7	15.2	27.2	27.2	19.7	24.0	24.0	18.3	20.9	20.9	16.9	
	2	16.0	23.9	18.7	13.4	20.0	16.8	11.0	16.5	14.8	19.0	28.5	20.6	16.2	24.3	18.9	13.5	20.3	16.9	22.2	33.3	22.3	19.3	28.9	20.5	16.3	24.5	18.8
	3	13.2	26.5	20.0	10.8	21.6	17.7	8.7	17.3	15.6	15.8	31.7	22.0	13.3	26.6	19.9	10.9	21.8	17.8	18.7	37.3	23.9	16.0	32.1	13.4	13.4	26.9	19.8
10	1	22.3	22.3	19.0	19.5	19.5	17.1	14.7	14.7	14.7	25.8	25.8	20.9	22.9	22.9	19.2	20.1	17.4	29.3	29.3	22.6	26.4	26.4	21.1	23.6	23.6	19.5	
	1.5	18.0	27.0	22.0	15.6	23.3	19.9	13.2	19.8	17.6	21.1	31.6	24.0	18.4	27.7	22.2	16.0	24.0	20.2	24.4	36.5	25.9	21.6	32.3	24.2	18.9	28.4	22.4
	2	15.2	30.4	23.7	12.9	25.7	21.5	10.8	21.5	19.0	18.0	36																

Performance data (cont)



42S COOLING CAPACITY (ΔT) 3-ROW COIL

UNIT SIZE	ΔT	75 F DB/63 F WB									80 F DB/67 F WB									85 F DB/71 F WB												
		40 F EWT			45 F EWT			50 F EWT			40 F EWT			45 F EWT			50 F EWT			40 F EWT			45 F EWT			50 F EWT						
		GPM	TC _b	SC _b	GPM	TC _b	SC _b	GPM	TC _b	SC _b	GPM	TC _b	SC _b	GPM	TC _b	SC _b	GPM	TC _b	SC _b	GPM	TC _b	SC _b	GPM	TC _b	SC _b	GPM	TC _b	SC _b	GPM	TC _b	SC _b	
03	8	3.0	11.8	8.4	2.2	8.9	7.1	1.6	6.2	5.8	—	—	—	3.0	12.1	8.4	2.2	8.9	7.1	—	—	—	—	—	—	—	—	—	3.1	12.3	8.4	
	10	2.2	11.1	8.1	1.6	8.1	6.7	1.1	5.7	5.4	2.9	14.4	9.4	2.2	11.2	8.0	1.6	8.1	6.7	—	—	—	—	—	—	—	—	3.0	14.8	9.3		
	12	1.7	10.2	7.7	1.2	7.3	6.3	0.9	5.1	5.0	2.3	13.6	9.0	1.7	10.3	7.6	1.2	7.4	6.3	2.9	17.2	10.3	2.3	13.8	8.9	1.7	10.4	7.6	10.4	7.6		
	14	1.3	9.3	7.2	0.9	6.6	5.9	0.7	4.6	4.5	1.8	12.7	8.7	1.4	9.4	7.2	1.0	6.6	5.9	2.3	16.3	9.9	1.8	12.9	8.6	1.4	9.5	7.3	9.5	7.3		
	16	1.0	8.3	6.8	0.7	5.8	5.5	0.5	4.0	4.0	1.5	11.7	8.2	1.1	8.5	6.8	0.8	6.0	5.5	1.9	15.3	9.5	1.5	11.9	8.2	1.1	8.6	6.9	8.6	6.9		
04	8	—	—	—	2.7	10.6	8.7	1.9	7.5	7.2	—	—	—	—	—	—	2.7	10.6	8.7	—	—	—	—	—	—	—	—	—	—	—		
	10	2.7	13.2	9.9	1.9	9.7	8.2	1.4	6.9	6.7	3.5	17.4	11.5	2.7	13.4	9.9	1.9	9.7	8.3	—	—	—	—	—	—	—	—	2.7	13.5	9.8		
	12	2.0	12.3	9.4	1.5	8.8	7.8	1.1	6.3	6.1	2.7	16.2	11.0	2.0	12.3	9.4	1.5	8.9	7.9	3.5	20.7	12.7	2.8	16.6	11.0	2.1	12.3	9.4	12.3	9.4		
	14	1.6	11.2	8.9	1.1	8.0	7.3	0.8	5.7	5.7	2.2	15.0	10.5	1.6	11.3	8.9	1.2	8.1	7.3	2.8	19.5	12.2	2.2	15.3	10.5	1.6	11.3	8.9	11.3	8.9		
	16	1.3	10.1	8.4	0.9	7.2	6.7	0.7	5.2	5.2	1.7	13.9	10.0	1.3	10.2	8.4	0.9	7.2	6.7	2.3	18.2	11.7	1.8	14.1	10.0	1.3	10.3	8.5	10.3	8.5		
06	8	5.4	21.7	15.7	4.1	16.5	13.3	3.1	12.3	11.2	7.0	27.9	18.1	5.6	22.2	15.6	4.2	16.6	13.3	—	—	—	—	—	—	—	—	5.6	22.6	15.6		
	10	4.1	20.4	15.1	3.1	15.3	12.7	2.3	11.4	10.5	5.3	26.3	17.4	4.1	20.6	15.0	3.1	15.5	12.8	6.6	32.9	19.8	5.4	27.0	17.3	4.2	20.6	15.0	20.6	15.0		
	12	3.1	18.8	14.3	2.3	14.1	12.1	1.8	10.6	9.8	4.1	24.8	16.8	3.2	19.2	14.4	2.4	14.4	12.2	5.2	31.3	19.1	4.2	25.3	16.6	3.3	19.5	14.4	19.5	14.4		
	14	2.5	17.2	13.6	1.9	12.9	11.4	1.4	9.4	8.9	3.3	23.1	16.0	2.5	17.3	13.7	1.9	13.3	11.6	4.2	29.5	18.4	3.4	23.6	16.0	2.6	18.0	13.8	18.0	13.8		
	16	2.0	15.7	12.8	1.5	11.9	10.6	—	—	—	—	2.7	21.2	15.2	2.0	16.1	13.0	1.5	12.3	10.8	3.5	27.7	17.6	2.7	21.9	15.3	2.1	16.5	13.1	16.5	13.1	
08	8	6.4	25.7	19.0	4.9	19.4	16.1	3.6	14.4	13.5	—	—	—	6.5	26.1	18.9	4.9	19.5	16.2	—	—	—	—	—	—	—	—	6.6	26.4	18.9		
	10	4.8	23.9	18.1	3.6	18.6	15.4	2.7	13.6	12.7	6.2	31.0	21.0	4.8	24.2	18.1	3.6	18.9	15.5	—	—	—	—	—	—	—	6.4	31.7	20.9	4.9	24.4	18.1
	12	3.7	22.2	17.3	2.8	16.6	14.6	2.1	12.5	11.7	4.8	29.0	20.1	3.7	22.4	17.3	2.8	16.9	14.8	6.1	36.8	23.0	4.9	29.6	20.1	3.8	22.6	17.4	22.6	17.4		
	14	2.9	20.2	16.4	2.2	15.3	13.7	1.5	10.5	10.5	3.9	26.9	19.8	3.0	20.7	16.6	2.2	15.7	13.9	5.0	34.6	22.1	3.9	27.4	19.3	3.0	21.0	16.7	21.0	16.7		
	16	2.3	18.4	15.5	1.7	13.9	12.7	1.1	9.0	9.0	3.1	24.9	18.4	2.4	19.0	15.7	1.8	14.4	13.0	4.1	32.4	21.2	3.2	25.6	18.5	2.4	19.4	16.0	19.4	16.0		
10	8	8.4	33.3	24.5	6.4	25.5	20.9	4.8	19.1	17.5	10.8	43.0	28.3	8.5	34.1	24.5	6.4	25.6	21.0	—	—	—	—	—	—	—	—	8.7	34.6	24.5		
	10	6.1	31.5	23.5	4.7	23.6	19.3	3.6	17.9	16.4	8.1	40.4	27.2	6.3	31.7	23.5	4.8	23.9	20.1	10.2	50.7	30.8	8.3	41.5	27.1	6.4	32.1	23.5	32.1	23.5		
	12	4.8	28.8	22.3	3.6	21.7	18.9	2.7	16.5	15.2	6.3	38.0	26.1	4.9	29.4	22.4	3.7	22.3	19.2	8.0	48.0	29.7	6.5	38.7	26.0	5.0	29.9	22.6	29.9	22.6		
	14	3.8	26.3	21.1	2.9	20.0	17.7	1.9	13.0	13.0	5.0	35.2	24.9	3.9	27.0	21.4	3.0	20.6	18.1	6.5	45.2	28.6	5.1	36.0	24.9	4.0	27.7	21.7	27.7	21.7		
	16	3.0	23.9	19.9	2.3	18.2	16.4	—	—	—	—	4.0	32.3	23.7	3.1	24.7	20.3	2.4	19.0	16.8	5.3	42.3	27.4	4.2	33.3	23.9	3.2	25.5	20.6	25.5	20.6	
12	8	9.3	37.0	27.5	7.0	28.0	23.5	5.3	21.1	19.6	—	—	—	9.4	37.6	27.5	7.1	28.2	23.6	—	—	—	—	—	—	—	—	9.5	38.1	27.5		
	10	6.9	34.4	26.3	5.2	26.0	22.4	4.0	19.8	18.4	8.9	44.6	30.4	7.0	34.8	26.4	5.3	26.3	22.6	—	—	—	—	—	—	—	9.1	45.6	30.4	7.0	35.2	26.4
	12	5.3	31.8	25.1	4.0	24.0	21.2	3.0	18.1	16.8	6.9	41.7	29.2	5.4	32.2	25.2	4.1	24.6	21.5	8.8	53.0	33.3	7.1	42.5	29.2	5.4	32.7	25.4	32.7	25.4		
	14	4.1	29.0	23.7	3.2	22.0	19.8	2.0	14.3	14.3	5.5	38.7	27.9	4.3	29.7	24.0	3.3	22.8	20.2	7.1	49.7	32.0	5.6	39.5	28.0	4.4	30.4	24.3	30.4	24.3		
	16	3.3	26.4	22.3	2.5	20.0	18.2	—	—	—	—	4.4	35.6	26.6	3.4	27.3	22.7	2.6	20.8	18.7	5.8	46.5	30.7	4.6	36.5	26.8	3.5	28.1	23.2	28.1	23.2	

42S COOLING CAPACITY (ΔT) 4-ROW COIL

UNIT SIZE	ΔT	75 F DB/63 F WB									80 F DB/67 F WB									85 F DB/71 F WB											
		40 F EWT			45 F EWT			50 F EWT			40 F EWT			45 F EWT			50 F EWT			40 F EWT			45 F EWT			50 F EWT					
		GPM	TC _b	SC _b	GPM	TC _b	SC _b	GPM	TC _b	SC _b	GPM	TC _b	SC _b	GPM	TC _b	SC _b	GPM	TC _b	SC _b	GPM	TC _b	SC _b	GPM	TC _b	SC _b	GPM	TC _b	SC _b	GPM	TC _b	SC _b
03	8	3.4	13.6	9.4	2.6	10.4	7.9	1.9	7.7	6.6	4.3	17.3	10.9	3.5	14.0	9.3	2.7	10.7	7.9	5.3	21.3	12.3	4.5	17.9	10.8	3.6	14.4	9.3	14.4	9.3	
	10	2.5	12.7	8.9	1.9	9.6	7.5	1.5	7.3	6.4	3.3	16.5	10.5	2.6	13.1	9.0	2.0	9.8	7.6	4.1	20.6	12.0	3.4	17.1	10.4	2.7	13.5	9.0	13.5	9.0	
	12	2.0	11.8	8.5	1.5	8.9	7.2	1.1	6.9	6.0	2.6	15.5	10.0	2.0	12.1	8.5	1.5	9.1	7.2	3.3	19.6	12.9	2.7	16.1	10.0	2.1	12.4	8.5	12.4	8.5	
	14	1.6	10.8	8.1	1.2	8.3	6.8	—	—	—	—	2.1	14.4	9.5	1.6	11.1	8.1	1.2	8.5	6.9	2.7	18.6	11.1	2.1	15.0	9.5	1.6	11.4	8.2	11.4	8.2
	16	1.3	10.0	7.7	—	—	—	—	—	—	—	1.7	13.3	9.1	1.3	10.3	7.7	—	—	—	2.2	17.4	10.6	1.7	13.8	9.1	1.3	10.5	7.8	10.5	7.8
04	8	4.2	16.7	11.7	3.2	12.8	9.9	2.4	9.4	8.3	5.3	21.2	13.5	4.3	17.0	11.6	3.2	13.0	9.9	6.6	26.3	15.3	5.5	22.0	13.4	4.4	17.4	11.6	17.4	11.6	
	10	3.1	15.6	11.2	2.4	11.8	9.4	1.8	8.9	7.9	4.1	20.3	13.1	3.2	16.0	11.2	2.4	12.0	9.5	5.0	25.1	14.8	4.2	20.7	12.9	3.3	16.3	11.2	16.3	11.2	
	12	2.4	14.4	10.6	1.8	10.8	9.0	1.4	8.3	7.4	3.2	19.0	12.5	2.5	14.8	10.7	1.9	11.1	9.1	4.0	24.1	14.4	3.3	19.6	12.5	2.5	15.1	10.7	15.1	10.7	
	14	1.9	13.2	10.1	1.4	10.0	8.5	1.1	7.6	6.9	2.5	17.6	11.9	1.9	13.5	10.1	1.5	10.3	8.7	3.3	22.8	13.8	2.6	18.3	11.9	2.0	13.9	10.2	13.9	10.2	
	16	1.5	12.1	9.5	1.2	9.3	8.0	—	—	—	—	2.0	16.2	11.3	1.6	12.4	9.6	1.2	9.6	8.2	2.7	21.3	13.2	2.1	16.8	11.4	1.6	12.8	9.8	12.8	9.8
06	8	6.4	25.8	17.9	5.0	19.8	15.2	3.7	14.7	12.8	—	—	—	6.6	26.4	17.8	5.0	20.1	15.2	—	—	—	—	—	—	—	—	6.8	27.0	17.8	
	10	4.9	24.4	17.3	3.7	18.6	14.6	2.8	14.1	12.4	6.2	31.2	20.0	5.0	24.9	17.2	3.8	18.8	14.6	—	—	—	—	—	—	—	5.1	25.4	17.1	25.4	17.1
	12	3.8	23.1	16.7	2.9	17.5	14.1	2.2	13.4	11.8	5.0	29.7	19.3	3.9	23.4	16.6	3.0	17.8	14.1	6.2	37.2	22.0	5.1	30.5	19.2	4.0	23.8	16.5	23.8	16.5	
	14	3.1	21.5	15.9	2.3	16.3	13.4	1.8	12.6	11.2	4.0	28.1	18.																		



42S COOLING CAPACITY CORRECTION FACTORS

ACTUAL CFM	UNIT SIZE											
	03		04		06		08		10		12	
	TH	SH	TH	SH	TH	SH	TH	SH	TH	SH	TH	SH
100	—	—	—	—	—	—	—	—	—	—	—	—
125	0.54	0.48	0.44	0.39	—	—	—	—	—	—	—	—
150	0.62	0.57	0.51	0.45	—	—	—	—	—	—	—	—
175	0.69	0.65	0.57	0.50	—	—	—	—	—	—	—	—
200	0.76	0.73	0.62	0.57	0.46	0.41	—	—	—	—	—	—
225	0.82	0.80	0.67	0.63	0.51	0.45	—	—	—	—	—	—
250	0.89	0.87	0.72	0.69	0.55	0.49	—	—	—	—	—	—
275	0.95	0.94	0.77	0.74	0.58	0.53	0.47	0.42	—	—	—	—
300	1.00	1.00	0.82	0.80	0.62	0.57	0.51	0.45	0.43	0.38	—	—
350	1.11	1.12	0.92	0.91	0.69	0.65	0.57	0.50	0.48	0.46	—	—
400	—	—	1.00	1.00	0.76	0.73	0.62	0.57	0.53	0.47	0.46	0.41
450	—	—	1.08	1.08	0.82	0.80	0.67	0.63	0.58	0.52	0.51	0.45
500	—	—	1.16	1.18	0.89	0.87	0.72	0.69	0.62	0.57	0.55	0.47
550	—	—	—	—	0.95	0.94	0.77	0.74	0.66	0.62	0.58	0.53
600	—	—	—	—	1.00	1.00	0.82	0.80	0.70	0.67	0.62	0.57
700	—	—	—	—	1.11	1.12	0.92	0.91	0.78	0.76	0.69	0.65
800	—	—	—	—	1.18	1.22	1.00	1.00	0.86	0.85	0.76	0.73
900	—	—	—	—	—	—	1.08	1.08	0.94	0.93	0.82	0.80
1000	—	—	—	—	—	—	1.16	1.18	1.00	1.00	0.89	0.87
1200	—	—	—	—	—	—	—	—	1.13	1.14	1.00	1.00
1400	—	—	—	—	—	—	—	—	—	—	1.11	1.12

LEGEND

SH — Sensible Heat
 TH — Total Heat

NOTE: Use Sensible Heat correction factors when calculating heating capacity.

BASE STEAM CAPACITIES (MBtuh)

UNIT SIZE	1-ROW COIL	2-ROW COIL
03	16.8	28.5
04	21.9	37.5
06	31.6	54.9
08	40.4	71.2
10	52.6	91.6
12	62.3	109.1

Performance data (cont)



42S HOT WATER HEATING CAPACITIES (MBtuh)

ROWS	UNIT SIZE	GPM						
		0.5	1.0	2.0	3.0	4.0	6.0	8.0
1 ROW	03	8.5	14.7	15.7	16.4	—	—	—
	04	9.2	15.5	18.4	19.2	—	—	—
	06	—	15.7	23.3	25.3	26.2	—	—
	08	—	16.6	25.7	28.2	29.0	—	—
	10	—	17.8	30.7	33.1	34.6	—	—
	12	—	18.8	32.6	34.4	36.2	—	—
2 ROW	03	13.7	17.4	19.1	19.8	—	—	—
	04	14.6	19.3	22.1	23.3	—	—	—
	06	—	28.2	34.4	35.7	37.7	—	—
	08	—	30.5	37.4	40.8	42.3	—	—
	10	—	19.6	43.2	49.0	51.6	55.0	—
	12	—	20.1	47.5	53.8	57.2	61.1	62.9
3 ROW	03	14.8	20.1	24.4	26.6	—	—	—
	04	17.3	24.9	27.8	29.4	—	—	—
	06	—	30.6	39.6	43.2	45.1	—	—
	08	—	33.6	46.8	51.0	54.0	—	—
	10	—	—	—	—	66.1	70.3	72.6
	12	—	—	—	—	69.4	78.0	80.8
4 ROW	03	17.0	23.3	24.3	25.1	—	—	—
	04	19.0	26.9	31.3	32.2	—	—	—
	06	—	34.1	46.4	48.0	52.4	—	—
	08	—	38.8	58.8	59.3	66.6	—	—
	10	—	—	—	—	71.8	76.6	79.7
	12	—	—	—	—	80.2	86.1	89.7

NOTE: Ratings based on nominal cfm, 70 F edb (entering dry bulb), 160 F EWT (entering water temperature).

42S HOT WATER CAPACITY CORRECTION FACTORS

ENTERING AIR TEMPERATURE (F)	ENTERING WATER TEMPERATURE (F)								
	100	110	120	130	140	150	160	170	180
50	.556	.666	.778	.889	1.000	1.111	1.222	1.334	1.445
55	.500	.611	.722	.834	.945	1.056	1.167	1.277	1.389
60	.444	.556	.666	.778	.889	1.000	1.111	1.222	1.334
65	.389	.500	.611	.722	.834	.945	1.056	1.167	1.277
70	.333	.444	.556	.666	.778	.889	1.000	1.111	1.222
75	.278	.389	.500	.611	.722	.834	.945	1.056	1.167
80	.222	.333	.444	.556	.666	.778	.889	1.000	1.111

NOTE: Hot Water Heating Capacity (MBtuh) = Base Capacity x Hot Water Capacity Correction Factor x SH (SH value found in Cooling Capacity Correction Factors table on page 101).

COIL Cv FACTOR

COIL TYPE 42SG,SH,SJ	UNIT SIZE					
	03	04	06	08	10	12
1 Row — Heat Only	1.3	1.3	1.1	1.1	1.0	1.0
2 Row — Heat Only	0.9	0.9	2.2	2.2	2.0	2.0
3 Row — Heat or Cool	0.7	0.7	1.8	1.8	2.7	2.7
4 Row — Heat or Cool	1.8	1.8	1.5	1.5	3.3	3.3

42S Series Units

MAIN RISER PRESSURE DROPS

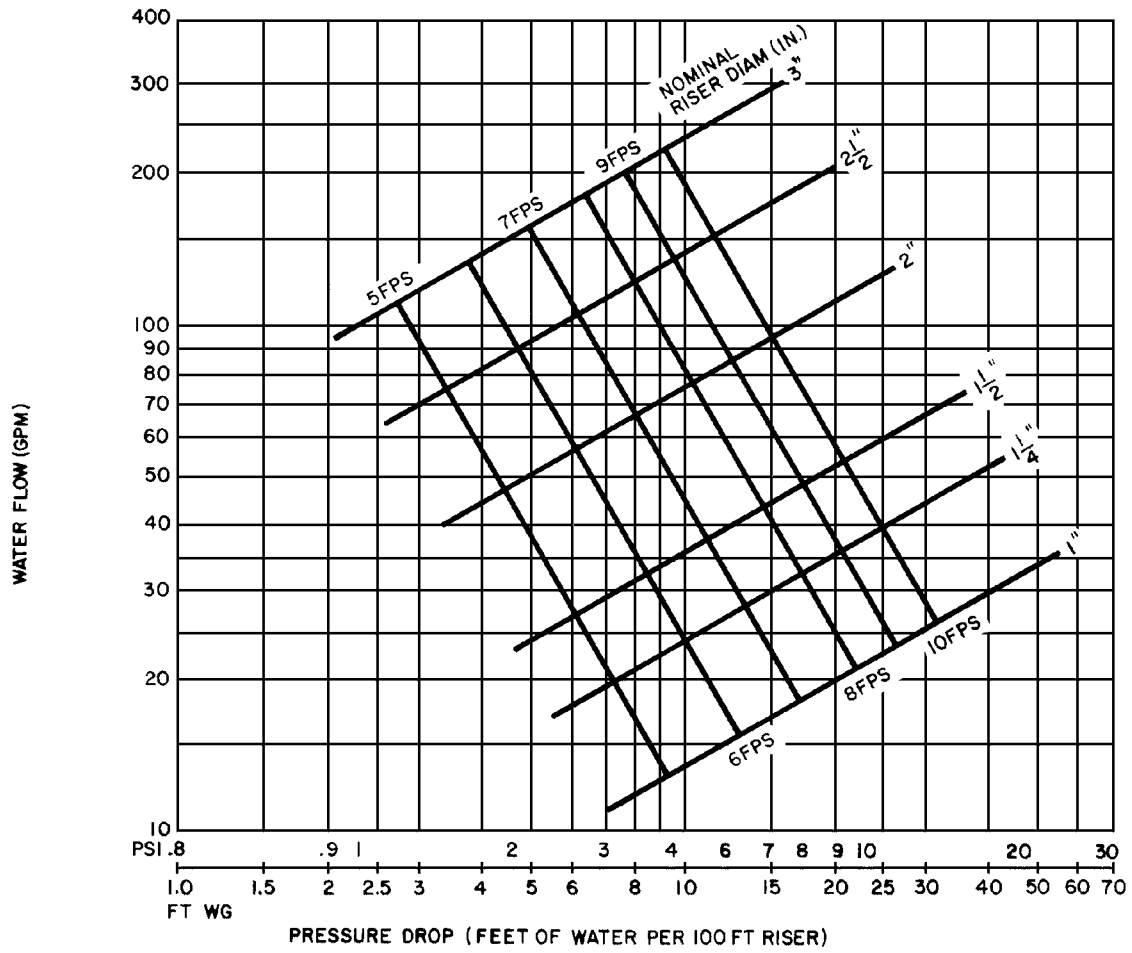

Electrical data



42S MOTOR PERFORMANCE DATA

VOLTAGE	FAN SPEED	03			04			06			08		
		Nominal Hp	Watts	Amps	Nominal Hp	Watts	Amps	Nominal Hp	Watts	Amps	Nominal Hp	Watts	Amps
115-1-60	High	1/30	85	.80	1/20	115	1.20	1/15	135	1.30	1/5	210	2.30
	Medium		60	.60		70	.70		100	1.00		145	1.40
	Low		40	.40		50	.50		65	.65		90	1.00
208-1-60	High	1/30	122	.31	1/20	114	.60	1/15	125	.70	1/5	185	.96
	Medium		66	.35		63	.32		95	.46		137	.77
	Low		42	.24		40	.21		70	.35		122	.68
230-1-60	High	1/30	140	.31	1/20	130	.60	1/15	140	.70	1/5	193	.96
	Medium		76	.36		72	.33		105	.46		152	.77
	Low		50	.25		47	.22		85	.38		140	.69
277-1-60	High	1/30	80	.30	1/20	115	.50	1/15	135	.60	1/6	200	.75
	Medium		60	.20		75	.30		100	.40		160	.60
	Low		40	.10		50	.20		77	.35		115	.50

VOLTAGE	FAN SPEED	10			12		
		Nominal Hp	Watts	Amps	Nominal Hp	Watts	Amps
115-1-60	High	1/5	325	3.30	1/4	420	4.30
	Medium		255	2.46		285	2.80
	Low		190	2.00		210	2.20
208-1-60	High	1/5	300	1.40	1/4	355	2.20
	Medium		214	1.10		235	1.20
	Low		162	.86		150	.80
230-1-60	High	1/5	320	1.40	1/4	405	2.20
	Medium		245	1.10		270	1.20
	Low		186	.91		180	.85
277-1-60	High	1/5	325	1.20	1/4	420	1.60
	Medium		270	1.00		300	1.17
	Low		180	.75		200	.90

42S ELECTRIC HEATER DATA

HEATER VOLTAGE	HEATER kW								
	1.0	1.5	2.0	3.0	4.0	5.0	6.0	8.0	10.0
	FLA								
120	8.3	12.5	16.7	25.0	—	—	—	—	—
208	4.8	7.2	9.6	14.4	19.2	24.0	28.8	38.5	48.1
240	4.2	6.2	8.3	12.5	16.7	20.8	25.0	33.3	45.5
277	3.6	5.4	7.2	10.8	14.4	18.0	21.7	28.9	36.1

LEGEND

FLA — Full Load Amps

NOTES:

- All heaters are single stage and single-phase.
- In all units using over 48 amps, the heating elements are subdivided and protected. Additional cost is incurred because of added components.
- A separate power source is required for motor and heaters except when motors and heaters of same voltage are ordered in conjunction with a single power source wiring option. This option, which meets NEC requirements, consists of a factory-furnished and installed junction box and fuse for 6.25 amp (max) fan and control circuit connection to a single power source. Power supply circuit to unit must be field furnished and installed in accordance with applicable codes.

UL Listing

The UL Listing signifies that Carrier's fan coil units have been examined by UL and comply with the organization's applicable standards. The Canadian Standards Association (CSA) and Underwriters' Laboratories of Canada also approve the fan coil units.



Guide specifications — 42C series



Fan Coil Unit — Horizontal Models

HVAC Guide Specifications — 42C

Size Range: 200 to 1200 Nominal Cfm

Carrier Model Numbers:

- 42CA (Furred-in)**
- 42CE (Furred-in with plenum)**
- 42CF (Furred-in, high static 400 to 1000 cfm)**
- 42CG (Cabinet)**
- 42CK (Cabinet, ducted)**

Part 1 — General

1.01 SYSTEM DESCRIPTION

Horizontal, 2-pipe or 4-pipe (or electric heat), room fan coil unit with furred-in, above ceiling cabinet for ducting, or with cabinet for exposed ceiling installations.

1.02 QUALITY ASSURANCE

Unit shall be tested and certified in accordance with ARI Standard 440 and base unit UL certified. (Units with special features may not have UL certification.) Each coil shall be factory tested for leakage at 350 psig air pressure with coil submerged in water. Insulation and adhesive shall meet NFPA-90A requirements for flame spread and smoke generation. All equipment wiring shall comply with NEC requirements.

1.03 DELIVERY, STORAGE AND HANDLING

Each unit shall be individually packaged from point of manufacture. Unit shall be handled and stored in accordance with the manufacturer's instructions.

Part 2 — Products

2.01 EQUIPMENT

A. General:

Factory-assembled, horizontal, blow-thru type fan coil for furred-in, exposed ceiling or ducted installations. Unit shall be complete with water coil(s), fan(s), motor(s), drain pan, and all required wiring, piping, controls and special features.

B. 42CA Base Unit:

1. Casing is 18-gage galvanized steel, lined on the inside with ½ in thick fiberglass Tuf-Skin™ II insulation, with a 1 in. long collar for supply duct connection. NO filter installed in base unit.
2. The drain pan shall be constructed of galvanized steel extending the entire length and width of the coil(s) and shall be pitched for drainage. The inside surface of the drain pan shall be coated with closed-cell fire-retardant foam insulation. An extension drain pan shall be provided for installation under factory-provided water valves at the job site.

C. 42CE,CF Furred-in Units:

Base 42CA unit with factory-installed plenum section (not on 42CF unit) and 1-in. fiberglass throw-away filter as shown on equipment drawings. The plenum shall be bottom or rear air return, shall enclose the fan/motor assemblies, and shall be lined

with ½-in. fiberglass Tuf-Skin II insulation. Unit shall have a removable panel to provide access to fan/motor assemblies and unit identification label.

D. 42CG Cabinet Units:

Base 42CA unit with stamped discharge grille, removable bottom access panel with stamped return-air grille, filter rack and 1-in. fiberglass throw-away filter. The panel shall be fastened with slotted head, positive-locking quarter-turn fasteners. The cabinet shall be coated with an Arctic White baked finish.

E. 42CK Ceiling, Furred-in with 2-in. Telescoping Ceiling Panel:

Base 42CA unit with full galvanized upper casing, adjustable height, hinged return-air ceiling panel, and 1-in. fiberglass throwaway filter. Panel shall be coated with an Arctic White baked finish.

F. Fans:

Direct-driven, double-width fan wheels with forward-curved blades shall be statically and dynamically balanced. Scrolls shall be constructed of galvanized steel. Fan wheels shall be constructed of galvanized steel.

G. Coils:

Standard base unit shall be equipped with a 3-row or 4-row coil for installation in a 2-pipe system. Additional coil depth and circuiting shall be provided for installation in a 4-pipe system as described in the Special Features section. All coils shall have ½-in. copper tubes and aluminum fins spacing; Coil fins are mechanical bonded to tube joints. The copper tubes comply with the ASTM B-75. The fin thickness is 0.0045-in and tube thickness is 0.016-in. All coils are tested with air under water and are suitable for design working pressures of 250 psig at 220 F. Burst tested at 350 psig.

H. Controls and Safeties:

Unit shall be furnished with a 3-speed, 4-position fan switch on a wall plate for field mounting. The fan motor(s) shall be equipped with integral automatic temperature reset for motor protection.

I. Operating Characteristics:

1. A one-coil unit installed in a 2-pipe system shall be capable of providing heating or cooling as determined by the operating mode of the central water supply system.
2. A double-circuit coil unit installed in a 4-pipe system shall be capable of providing sequenced heating and cooling.

J. Electrical Requirements:

Standard unit shall operate on 120 v, single-phase, 60 Hz electric power. All internal wiring shall be in flexible conduit.

K. Motor(s):

Fan motors shall be 3-speed, 120 v, single-phase, 60 Hz, permanent split capacitor type, with sleeve

Guide specifications — 42C series (cont)



type bearings and oversized oil reservoirs to ensure lubrication.

L. Special Features:

Certain standard features are not applicable when the features designated by * are specified. See your local Carrier Sales Offices for amending specifications.

- * 1. Unit coil(s) shall be equipped with automatic air vents.
- * 2. For installation in a 4-pipe system, unit shall be equipped with a 3-row cooling/one-row heating split-circuit coil, a 3-row cooling/2-row heating split-circuit coil, or a 4-row cooling/one-row heating split-circuit coil as required. Coil connections to be as shown on the equipment drawings.
- * 3. For installation on a 2-pipe system, units shall be equipped with a 4-row high capacity coil.
- * 4. Fan motor shall be permanent split-capacitor type, 208, 220, 240, or 277-v, single-phase, 50 or 60 Hz as specified on the equipment schedule.
- * 5. Unit shall be equipped with electric strip heaters mounted on the entering air side of the water coil. Heaters shall include high limit cutout with auto reset and contactor. Capacity and voltage shall be as shown on the equipment schedule. When fan motor and electric heater are selected at the same voltage and connected to a single power source, a junction box and fuse shall be factory furnished and installed to protect the motor and control circuit.
- * 6. Filter track and cleanable filter shall be installed in the plenum.
 - 7. Extra throwaway or cleanable filters shall be furnished for field installation as indicated on the equipment schedule.
- * 8. Drain pan shall include a second drain connection located above the main drain connection to act as an indicator that the main drain is plugged.
- 9. A hinged, bar type aluminum return-air grille with filter holder shall be furnished for field installation (42CA, CE, CF).
- *10. Discharge-air grille with double deflection, aluminum construction with aluminum frame shall be factory installed as shown on the equipment schedule. Aluminum grilles shall have a natural anodized finish (42CG only).
- *11. Double-deflection discharge-air grille with steel construction shall be factory installed as shown on equipment schedule. Grille shall be painted to match cabinet (42CG only).
- 12. Discharge-air grille with double deflection, aluminum construction shall be furnished for field installation as shown on equipment schedule. Aluminum grilles shall have a natural anodized finish (42CA, CE, CF, CK).
- 13. Manual stop, gate, balancing, combination balance and stop, ball type, and flow control valves shall be factory furnished and installed as indicated on the equipment drawings.
- 14. Motorized 2-way and 3-way valves shall be factory wired and assembled with tubes terminating in belled ends or unions for field attachment to the coil. Valves shall be packaged within unit to prevent shipping damage.
- 15. Heating and/or cooling wall thermostat shall be factory furnished for field installation.
- 16. Automatic changeover device(s) shall be factory wired for field installation on the supply piping.
- 17. Sequenced heating and cooling wall thermostat shall be factory furnished for field installation.
- 18. Tamper proof fasteners shall be installed on the access panel on cabinet models.
- 19. Unit shall operate on 208, 220, 240, or 277-v, single-phase, 50 or 60 Hz electrical power as specified on the equipment schedule. All wiring shall be in flexible metal conduit.

Guide specifications — 42D series



Fan Coil Unit — Ducted Models

HVAC Guide Specifications — 42D

Size Range: **600 to 2000 Nominal Cfm**

Carrier Model Numbers:

42DA (Ceiling Furred-in)

42DC (Ceiling Furred-in with Plenum)

42DD (Vertical with Galvanized Casing)

42DE (Ceiling with Galvanized Casing)

42DF (Ceiling Exposed Cabinet)

Part 1 — General

1.01 SYSTEM DESCRIPTION

Horizontal, 2-pipe or 4-pipe or electric heat fan coil unit for ducted installations; horizontal furred-in or exposed ceiling model, ceiling cabinet, or vertical model with galvanized casing for closet or utility room installation.

1.02 QUALITY ASSURANCE

Units shall be UL approved, except for 42DF. All units shall be CSA approved, including 42DF. Each coil shall be factory tested for leakage at 350 psig air pressure with coil submerged in water. Insulation and adhesive shall meet NFPA-90A requirements for flame spread and smoke generation. All equipment wiring shall comply with NEC requirements. The 42DF model shall be tested and certified in accordance with ARI Standard 440.

1.03 DELIVERY, STORAGE AND HANDLING

Unit shall be handled and stored in accordance with the manufacturer's instructions.

Part 2 — Products

2.01 EQUIPMENT

A. General:

Factory assembled, horizontal or vertical blow-thru ducted fan coil unit. Unit shall be complete with water coil(s), fan(s), motor(s), drain pan, and all required wiring, piping, controls and special features.

B. Horizontal, Furred-in Base Unit (42DA):

1. Outside panels shall be galvanized steel, lined on the inside with ½-in. thick fiberglass Tuf-Skin™ II insulation and a 1 in. long collar for supply duct connection.
2. The drain pan shall be constructed of 18-gage galvanized steel extending the entire length and width of coil(s) and pitched for drainage. The inside surface of the drain pan shall be coated with closed-cell, fire retardant foam. An extension drain pan shall be provided for installation at the jobsite under the factory-furnished electric water valves.

C. Horizontal Base Unit with Plenum for Concealed Installation (42DC):

Unit shall have a factory-installed, 18-gage galvanized steel plenum section and 1-in. throwaway filter. The plenum shall be either bottom or rear return, lined with ½-in. thick fiberglass Tuf-Skin II

insulation and include a removable panel to provide access to the fan/motor assembly.

D. Horizontal, Enclosed Unit for Concealed Installation (42DE):

Unit shall be constructed of galvanized steel with removable panels for access to internal components. Units have ½-in. fiberglass Tuf-Skin II insulation, filter track with 1-in. throwaway filter, 1-in. supply collar, and 2½-in. return-air collar on rear of unit for duct connection.

E. Horizontal Cabinet Unit for Exposed Installation (42DF):

Unit shall be constructed of steel with arctic white re-coatable baked enamel finish. Cabinet shall be lined with ½-in. fiberglass Tuf-Skin II insulation and have removable bottom access panel. Unit shall include hinged bar type return-air grille on rear of unit with 1-in. throwaway filter and integral double deflection supply-air grille.

F. Vertical, Enclosed Unit for Closet Installation (42DD):

Unit shall be constructed of galvanized steel with ½-in. fiberglass Tuf-Skin II insulation. Unit shall include front return-air opening with 1-in. throwaway filter and 1-in. supply-air duct collar.

G. Fans:

Direct-driven, double-width fan wheels shall have forward-curved blades, and be statically and dynamically balanced, with scrolls and fans constructed of galvanized steel.

H. Coils:

Standard base unit shall be equipped with a 4-row coil for installation in a 2-pipe system. Additional coil depth and circuiting shall be provided for installation in a 4-pipe system as described in the Special Features section. All coils shall have ½-in. copper tubes and aluminum fins spacing; Coil fins are mechanical bonded to tube joints. The copper tubes comply with the ASTM B-75. The fin thickness is 0.0045-in. and tube thickness is 0.016-in. All coils are tested with air under water and are suitable for design working pressures of 250 psig at 220 F. Burst tested at 350 psig.

I. Controls and Safeties:

Unit shall be furnished with a 3-speed, 4-position fan switch on a wall plate for field mounting. The fan motor(s) shall be equipped with integral, automatic reset thermal overload motor protection.

J. Operating Characteristics:

A single-circuit coil unit installed in a 2-pipe system shall be capable of providing heating or cooling as determined by the operating mode of the central water supply system. A double circuit coil unit installed in a 4-pipe system shall be capable of providing sequenced heating and cooling.

Guide specifications — 42D series (cont)



K. Electrical Requirements:

Standard unit shall operate on 115-v, single-phase, 60-Hz electric power, and all exposed wiring shall be in a flexible conduit.

L. Motor(s):

Fan motors shall be 3-speed permanent split capacitor type, 115 volts, with sleeve type bearings and oversized oil reservoirs.

M. Special Features:

Certain standard features are not applicable when the features designated by * are specified. See your local Carrier Sales Office for amending specifications.

- * 1. Unit Coil(s) shall be equipped with automatic air vents.
- * 2. Unit shall be equipped with a high-capacity 6-row coil for installation in a 2-pipe chilled water system or DX system.
- * 3. For installation in a 4-pipe chilled water system or DX system, unit shall be equipped with either a 4-row cooling/one-row heating split circuit, or a 4/2 split circuit or a 6/1 split circuit (except 42DD) as required.
- * 4. Fan motor(s) shall be permanent split capacitor type, 208, 230, or 277 volts for low-static applications (42DF) or 208, 230 or 277 volts for high-static applications (42DA, DC, DD, and DE). 220-volt fan motor shall be available for 50 Hz applications.
- * 5. Electric Heat:
 - a. Unit shall be equipped with electric resistance strip heaters mounted on the entering air side of the water coil.
 - b. Heaters shall include automatic reset high limit cutout, contactor, factory-furnished junction box and fuse to protect the motor.
 - c. Heaters shall be single-stage, single-phase, 120, 208, 220, 240 or 277 volts, for 50 Hz or 60 Hz applications. Capacity shall be as shown on the equipment schedule.
- d. Control circuit for single power source connection is available and must be used when motors and heaters are of the same voltage.
- * 6. Filter track and cleanable filter shall be installed in the plenum (42DC, DD, and DE only).
- 7. Extra throwaway or cleanable filters shall be furnished for field installation as indicated on the equipment schedule.
- 8. Drain pan shall include a second drain connection located above the main drain connection to act as an indicator that the main drain is plugged.
- 9. Removable drain pan extension (drip lip) shall be available for field installation under electric water valves.
- 10. Six-in. diameter outside air opening with duct collar shall be provided to duct outside ventilation air to unit, with or without manual outdoor air damper.
- 11. Gate, balancing and combination balance and stop (ball) and flow control valves shall be factory furnished and installed as indicated on the equipment drawings.
- 12. Motorized 2-way and 3-way valves shall be wired to the unit. In order to prevent shipping damage, they shall be factory assembled in the valve package. The valve packages shall terminate with belled ends or unions for field attachment to the coil.
- 13. Heating and/or cooling thermostat (SPDT) shall be factory furnished for field installation (2-pipe system).
- 14. Automatic changeover device(s) shall be factory wired for field installation on supply piping (2-pipe system).
- 15. Sequenced heating and cooling wall thermostat shall be factory furnished for field installation (4-pipe system).

Fan Coil Unit — Vertical Stack Models

HVAC Guide Specifications — 42S

Size Range: **300 to 1200 Nominal Cfm**

Carrier Model Numbers:

42SGA (Furred-in)

42SHA (Cabinet)

42SJA (Furred-in, Back-to-Back)

Part 1 — General

1.01 SYSTEM DESCRIPTION

Stack fan coil units, 2-pipe, 4-pipe or electric heat for furred-in or exposed cabinets that are floor mounted in multi-story buildings.

1.02 QUALITY ASSURANCE

Units shall be tested and certified in accordance with ARI standard 440, latest edition. All units shall be UL and CSA approved. Each coil shall be factory tested for leakage at 350 psig air pressure with coil submerged in water. Insulation and adhesive shall meet NFPA-90A requirements for flame spread and smoke generation. All equipment wiring shall comply with NEC requirements.

1.03 DELIVERY, STORAGE AND HANDLING

Unit shall be handled and stored in accordance with the manufacturer's instructions.

Part 2 — Products

2.01 EQUIPMENT

A. General:

Factory assembled, stack fan coil units. Units are complete with water coil(s), fan(s), motor(s), drain pan, and all required wiring, piping, controls, and special features.

B. Cabinet Stack Unit (42SH):

Outside panels are made of 18-gage galvanized steel coated with baked-on enamel finish and are fabricated with no exposed fasteners. The interior surfaces shall be lined with ½-in. thick fiberglass Tuf-Skin™ II insulation. The standard cabinet unit has factory-installed double deflection discharge grille(s) and stamped supply grille. Controls are factory wired and mounted in small access panel at front of unit.

C. Furred-In Stack Unit (42SG):

The unit shall be constructed of 18-gage galvanized steel frame and 18-gage galvanized steel back panel. The fan coil is open or enclosed for furred-in installation. These units are designed to have the wallboard applied directly to the unit surface and all openings have standard ½-in. thick fiberglass Tuf-Skin II insulation. Units have double deflection aluminum discharge grille(s) and painted, stamped (standard) or bar-type aluminum (optional) return-air grille panel. Removable return-air grille provides access to all internal piping and wiring. Controls are provided with a quick disconnect plug for field-mounting on front of unit.

D. Back-To-Back Furred-In Stack Units (42SJ):

The open unit shall be constructed of 18-gage galvanized steel frame and 18-gage galvanized steel back panel. These units are similar to the 42SG but are actually two completely separate units contained in one cabinet that share a common set of risers. These units are designed to have the wallboard directly applied to the unit surface and openings have standard ½-in. drywall flanges. The interior surfaces shall be lined with ½-in. thick fiberglass Tuf-Skin II insulation. Units have double deflection aluminum supply grille(s) and painted, stamped (standard) or bar-type aluminum (optional) return-air grille panel. Removable return-air grille provides access to all internal piping and wiring. Controls are provided with a quick disconnect plug for field-mounting on front of unit.

E. Drain Pan:

Drain pan shall be formed of 18-gage steel and shall be coated inside with fire-retardant closed-cell foam insulation. Water never touches the metal pan eliminating the possibility of corrosion. The drain is factory piped to the drain riser that has a removable "P-trap" allowing easy cleaning.

F. Filter:

A filter track complete with 1-in. fiberglass throw-away filter shall be installed in the unit. Optional permanent filters are available.

G. Fan:

1. Centrifugal fan shall be directly-driven by an electric motor.
2. Fan wheel shall be double-width type with forward-curved blades and shall be statically and dynamically balanced.
3. Fan wheel and scroll shall be constructed of galvanized steel.

H. Coil:

1. Standard base unit shall be equipped with a 3-row for installation in a 2-pipe system. Additional coil depth and circuiting shall be provided for installation in a 4-pipe system as described in the Special Features section.
2. All coils shall have ½-in. copper tubes and aluminum fins spacing; Coil fins are mechanical bonded to tube joints. The copper tubes comply with the ASTM B-75. The fin thickness is 0.0045-in. and tube thickness is 0.016-in. All coils are tested with air under water and are suitable for design working pressures of 250 psig at 220 F. Burst tested at 350 psig.
3. Coil shall be equipped with a manual air vent and shall be piped to supply and return risers with valves as specified on the equipment drawings.
4. Piping between coil and risers shall include loops to compensate for maximum riser expansion and contraction of 1½ inches.

Guide specifications — 42S series (cont)



I. Risers:

1. Standard factory-furnished and installed risers shall be 104 in. long with 3-in. belled ends at the top such that only one sweat connection shall be required at each floor to join one riser to another.
2. Risers shall be Type M copper insulated with 1/2-in. thick synthetic rubber.
3. Standard supply and return risers shall be 1 1/4 in. diameter, drain riser shall be 1 in. diameter.

J. Valves:

The factory furnished and installed piping shall include two ball valves and one 2-way motorized valve. The ball valves shall be rated at 150 psig.

K. Controls and Safeties:

1. Controls:

- a. Standard controls for a 2-pipe system shall consist of a 3-speed fan switch, heating/cooling thermostat (SPDT) and an automatic changeover device.
- b. Unit controls shall be mounted behind the access door on the return air panel.

2. Safeties:

Unit fan motor shall be equipped with integral motor protection.

L. Operating Characteristics:

1. A unit with a conventional coil, installed in a 2-pipe system, shall be capable of providing heating or cooling as determined by the operating mode of the central water supply system.
2. A unit with a row-split coil, installed in a 4-pipe system, shall be capable of providing sequenced heating and cooling.

M. Electrical Requirements

Standard unit shall operate on 115-v, single phase, 60-Hz electrical power supply.

N. Motor:

1. Fan motor shall be 3-speed, 115-v, single phase, 60-Hz, permanent split capacitor type, factory mounted on the blower housing.
2. Bearings shall be of the sleeve type with oil tubes and oversized oil reservoir to assure positive lubrication and minimum service requirements.

O. Special Features:

Certain standard features are not applicable when the features designated by * are specified.

- * 1. Unit coil shall be equipped with automatic air vents.
- * 2. Unit shall be equipped with a 4-row coil for installation in a 2-pipe system.

- * 3. For installation in a 4-pipe system, unit shall be equipped with:
 - a. A 3/1, 3/2 or 4/1 row-split coil, as shown on equipment drawings for cooling and heating.
 - b. Two each 1 1/4 in. diameter supply and return risers and one 1 in. diameter drain riser.
 - c. Two gate valves, 2 combination balance and stop valves and two 2-way motorized valves. The gate and combination valves shall be rated at 150 psig.
 - d. Three-speed fan switch and a sequenced heating and cooling thermostat.
- * 4. Unit shall be equipped with 3-way motorized valves.
- * 5. Supply and return risers shall be 1 in., 1 1/2 in., 2 in. or 2 1/2 in. diameter as shown on the equipment drawings.
- * 6. Floor-to-floor height of risers shall be as specified on the equipment drawings.
- * 7. Supply and return risers shall be Type L copper.
- * 8. Drain riser shall be Type DWV copper.
- * 9. Insulation on risers shall be 3/4-in. thick synthetic rubber.
- * 10. Unit shall be equipped with a separate reverse-return riser with size as shown on the equipment drawings.
11. Automatic balancing check valve(s) shall be factory installed as shown on the equipment drawings.
- * 12. Motor shall be 3-speed, single phase, 60 Hz permanent split capacitor type for 208, 230 or 277 volts or 50 Hz permanent split capacitor type for 220 volts.
- * 13. Double-deflection supply grille(s) shall be finished with white primer or Arctic White paint. Additional double-deflection supply grille(s) shall be furnished for field installation.
14. Ceiling skirts for exposed stack units shall be provided for field trim and installation.
15. A fresh-air opening shall be provided as shown on the equipment drawings.
- * 16. One-in. thick cleanable filters shall be installed in the filter track.
17. Unit shall be equipped with nichrome wire electric strip heaters for total or auxiliary electric heat as specified on the equipment schedule.
 - a. Heaters shall be protected by an automatic reset safety cutout switch and a fusible link.
 - b. Heater capacity shall be as specified on the equipment schedule.
 - c. Heaters shall be single phase, 60 Hz for 120, 208, 240 or 277 volts as specified on the equipment schedule.



- *d. For total electric heat, unit controls shall include a sequenced heating and cooling thermostat in lieu of the heating/cooling thermostat and automatic changeover device.
- e. For auxiliary electric heat, unit controls shall include 2 additional automatic changeover devices. A junction box and fuse shall be factory-furnished and installed to protect the motor and control circuit when electric heaters are installed in a unit with a single power source.

- 18. Fused or unfused disconnect switch shall be provided for field installation. Switch shall be suitable for single phase, 60 Hz service for 115, 208, 240 or 277 volts as specified on the equipment schedule.

Guide specifications — 42V series



Fan Coil Unit — Vertical Models

HVAC Guide Specifications — 42V

Size Range: 200 to 1200 Nominal Cfm

Carrier Model Numbers:

- 42VA (Furred-in)
- 42VB (Cabinet)
- 42VC (Furred-in, low boy, 200 to 600 cfm)
- 42VE (Cabinet, low boy, 200 to 600 cfm)
- 42VF (Cabinet, slant top)
- 42VG (Furred-in, wall, 150 and 300 cfm)

Part 1 — General

1.01 SYSTEM DESCRIPTION

Vertical, 2-pipe or 4-pipe, or electric heat, room fan coil unit for furred-in, or cabinet floor mounted installation. (42VC and VE are low profile units.)

1.02 QUALITY ASSURANCE

Unit shall be tested and certified in accordance with ARI Standard 440 and base unit UL certified. (Units with special features may not have UL certification.) Each coil shall be factory tested for leakage at 300 psig air pressure with coil submerged in water. Insulation and adhesive shall meet NFPA-90A requirements for flame spread and smoke generation.

1.03 DELIVERY, STORAGE AND HANDLING

Each unit shall be individually packaged from point of manufacture. Unit shall be handled and stored in accordance with the manufacturer's instructions.

Part 2 — Products

2.01 EQUIPMENT

A. General:

Factory-assembled, vertical, blow-thru type floor mounted fan coil for furred-in or exposed installations. Unit shall be complete with water coil, fan(s), motor(s), drain pan, and all required wiring, piping, controls and special features.

B. 42VA, VC Base Unit:

1. Outside panels are made of 18-gage galvanized steel. Lined on the inside with ½ in. thick fiberglass Tuf-Skin™ II insulation, with a 1 in. long collar for top supply duct connection. Units shall be supplied with a 1-in. fiberglass throw-away filter.
2. The drain pan shall be constructed of 18-gage galvanized steel extending the entire length and width of the coil(s) and pitched for drainage. The inside surface of the drain pan shall be coated with closed cell fire retardant foam insulation. An extension drain pan shall be provided for installation under the water valves at the job-site.

C. 42VB, VE, VF Cabinet Models:

1. Cabinet models shall be coated with an Arctic White baked finish, and include a 1-in. fiberglass throwaway filter.

2. Cabinet models shall be free standing with 2 access doors. A stamped supply-air grille shall be included in the top of the cabinet. (Overall cabinet height shall not exceed 14½ in. on low profile 42VE unit.)
3. The 42VF top panel shall slope down from back to front at an angle of 25 degrees. Standard stamped grille shall provide a discharge into the room at a nominal 67 degrees from the vertical.

D. 42VG Furred-In Model:

1. Cabinet shall be fabricated of 18-gage galvanized steel with ½ in. thick fiberglass insulation. Cabinet shall be coated with baked enamel finish. Removable front panel shall provide service access and shall include die-formed supply- and return-air grilles.
2. Combination condensate pan and fan deck shall be insulated with closed-cell fire-retardant foam.

E. Fans:

Direct-driven, double-width fan wheels shall have forward-curved blades and shall be statically and dynamically balanced. Scrolls and fan wheels shall be constructed of galvanized steel.

F. Coils:

Standard base unit shall be equipped with a 3-row (42VA, VB, VF units) or 2-row coil (42VC, VE, VG units) for installation in a 2-pipe system. Additional coil depth and circuiting shall be provided for installation in a 4-pipe system as described in the Special Features section. All coils shall have ½ in. copper tubes and aluminum fins spacing; Coil fins are mechanical bonded to tube joints. The copper tubes comply with the ASTM B-75. The fin thickness is 0.0045 in and tube thickness is 0.016 in. All coils are tested with air under water and are suitable for design working pressures of 250 psig at 220 F. Burst tested at 350 psig.

G. Controls and Safeties:

Unit shall be furnished with a 3-speed, 4-position fan switch on a wall plate for field mounting on furred-in units. Cabinet units shall be furnished with a factory-installed 3-speed, 4-position fan switch. Internal wiring from motor and valves shall be in flexible metal conduit, terminating in the junction box.

H. Operating Characteristics:

1. A one-coil unit installed in a 2-pipe system shall be capable of providing heating and cooling as determined by the operating mode of the central water supply system.
2. A double-circuit coil unit installed with a 4-pipe system shall be capable of providing sequenced heating and cooling.



I. Electrical Requirements:

Standard unit shall operate on 120 v, single-phase, 60 Hz electric power. All internal wiring shall be in flexible conduit.

J. Motor(s):

Fan motor(s) shall be 3-speed, 120 v, single-phase, 60 Hz, permanent split capacitor type with sleeve type bearings and oversized oil reservoirs to ensure lubrication. Motors shall have integral automatic temperature reset for motor protection.

K. Special Features:

Certain standard features are not applicable when the features designated by * are specified. See your local Carrier Sales Office for amending specifications.

- * 1. Unit coil(s) shall be equipped with automatic air vents.
- * 2. For installation in a 2-pipe system, unit shall be equipped with a high-capacity 4-row coil (42VA,VB,VF units) or a high-capacity 3-row coil (42VC,VE).
- * 3. For installation in a 4-pipe system, 42VA,VB, VF units shall be equipped with a 3-row cooling/one-row heating split-circuit coil, a 3-row cooling/2-row heating split-circuit coil or a 4-row cooling/one-row heating split-circuit coil as required. The 42VC,VE units shall be equipped with a 2-row cooling/one-row heating split-circuit coil.
- * 4. Fan motor shall be permanent split-capacitor type, 208, 220, 240, or 277-v, single-phase, 50 or 60 Hz as specified on the equipment schedule.
- * 5. Unit shall be equipped with electric resistance sheath type heaters mounted on the leaving air side of the water coil. Heaters shall include high limit cutout with auto reset and contactor. Capacity and voltage shall be as shown on the equipment schedule. When fan motor and electric heater are selected at the same voltage and connected to a single power source, a junction box and fuse shall be factory furnished and installed to protect the motor and control circuit. Unit height on 42VC and VE shall be increased by 2 in. to accommodate heaters.
- * 6. Cleanable filter shall be factory installed in the filter track.
- 7. Extra throwaway or cleanable filters shall be furnished for field installation as indicated on the equipment schedule.
- * 8. Leveling legs shall be factory installed on the unit and permit a maximum adjustment of $\frac{3}{4}$ inch.
- 9. Switch box complete with switch shall be factory installed on the unit.
- 10. Discharge-air grille with double deflection aluminum construction as shown on the equipment schedule shall be furnished for field installation (42VA,VC units).
- 11. Discharge-air grille with double deflection steel or aluminum construction shall be shipped installed in the unit. (42VB,VF,VE units). Steel grilles shall be painted to match cabinet. Aluminum grilles shall be a natural anodized finish.
- 12. Reverse-stamped grille (42VB,VF units) shall provide a discharge into the room at a nominal 23 degrees from vertical.
- 13. Stamped type aluminum return-air grille with filter holder shall be furnished for field installation. (Not available for VG unit.)
- 14. Manual stop, gate, balancing, combination balance and stop (ball type), and flow control valves shall be factory furnished and installed as indicated on the equipment drawings.
- 15. Motorized 2-way and 3-way valves shall be factory assembled and wired to unit with tubes terminating in belled ends or unions for field attachment to the coil. Valves shall be packaged within the unit to prevent shipping damage.
- 16. Heating and/or cooling wall thermostat shall be factory furnished for field installation.
- 17. Heating and/or cooling thermostat shall be factory wired and installed.
- 18. Automatic changeover device(s) shall be factory wired for field installation on the supply piping.
- 19. Sequenced heating and cooling wall thermostat shall be factory furnished for field installation.
- 20. Sequenced heating and cooling thermostat shall be factory wired and installed.
- *21. Tamper proof fasteners shall be installed on front panel and access doors on cabinet models.
- *22. Cabinet shall be painted with the color specified on the equipment schedule.
- *23. Factory-installed outside air damper shall be manually adjustable through the return air opening or shall be arranged for remote manual adjustment, complete with linkage and electric motor to open damper when fan is on. Or, unit shall have a $\frac{3}{16}$ -in. shaft extending outside the unit for installation of a field-supplied damper (42VA,VB,VF).
- 24. Wall panels, painted with specified color, shall be furnished for top discharge or front discharge recessed unit (42VA only).
- 25. Unit shall operate on 208, 220, 240, or 277-v, single-phase, 50 or 60 Hz electrical power as specified on the equipment schedule. All wiring shall be in flexible conduit.
- 26. Outside air wall boxes for field installation.

Index



42CA section 27-66
42CE section 27-66
42CF section 27-66
42CG section 27-66
42CK section 27-66
42DA section 67-89
42DC section 67-89
42DD section 67-89
42DE section 67-89
42DF section 67-89
42SG section 90-104
42SH section 90-104
42SJ section 90-104
42VA section 27-66
42VB section 27-66
42VC section 27-66
42VE section 27-66
42VF section 27-66
42VG section 27-66
Air delivery
42C 52-56
42D 81-83
42S 98
42V 57-59
Application data 13-25
ARI rating data
42C 28
42D 67
42S 90
42V 28
Arrangements, 42S 15
Automatic changeover 12
Certifications and listings 28, 67, 90
Coil connections 20, 44-46, 74, 75
Controls 10-12
Selection guide 10
Remote-mounted 11
Unit-mounted 11, 12
Cooling capacities
42C 48, 49
42D 77-80
42S 99, 100
42V 48-51
Cv factor 22, 63, 86, 102
Dimensions
Accessories
42C 43-47
42D 74-76
42S 95-97
42V 43-47
Base unit
42C 32-36
42D 69-73
42S 92-94
42V 37-42
Direct expansion
42C 60
42D 85
42V 61
Electric heaters 10, 24, 25, 64, 87, 104

Electrical data
42C 64-66
42D 87-89
42S 104
42V 64-66
Features/Benefits 1-6
Filters
42C 31
42D 68
42S 91
42V 31
Guide specifications
42C 105, 106
42D 107, 108
42S 109-111
42V 112, 113
Heating capacities
Electric
42C 25
42D 25
42S 25
42V 25
Hot water
42C 62
42D 86
42S 102
42V 62
Steam
42C 63
42D 86
42S 101
42V 63
Isolation valves 20
Model number nomenclature
42C 27
42D 67
42S 90
42V 27
Motor data
42C 64, 65
42D 88, 89
42S 104
42V 65, 66
Options and accessories 7-9
Outside air damper 43
Panel combinations 7
Performance data
42C 48-63
42D 77-86
42S 98-103
42V 48-63
Physical data
42C 31-42
42D 68-73
42S 91-94
42V 31-42
Piping 14, 16-19
Return air grilles 47, 75
Risers 8, 15, 103
Selection procedure 26

Service fittings 20
Shipping weights
42C 31
42D 68
42S 91
42V 31
Sound data
42C 29
42D 68
42S 91
42V 30
Strainer 18, 20
Supply grilles 47, 75
Thermostat 11, 12
Valve package arrangements 21
Wall boxes 47
Wall panels 47, 95-97
Water flow balancing
Components 20

